

NEWARK

Swivel Recliner & Footstool

ASSEMBLY INSTRUCTIONS



STOP! IMPORTANT:

Please read this manual carefully before beginning assembly of this product.
Keep this manual for future reference.

Use the product only in a way specified under instruction manual.
Incorrect usage voids product warranty.

FIRE RETARDANCY

The leathers/bonded leathers/PUs/fabrics meet the requirements of BS5852 Part 1 Source 0 (Cigarette) Ignition Source 1 (Match) as laid out in the UK Furniture and Furnishings (Fire)(Safety) Regulations 1988 with amendments in 1989, 1993 and 2010.



IMPORTANT

This product is designed to seat people up to a maximum of 115kgs (18 stone)

Check and re-tighten parts/nuts & bolts every three months

**Please retain these instructions for future reference and in case of any queries,
please quote the following batch number to your retailer.**

**(The batch number is also located on the underside of the seat pad or
footstool pad)**

SAFETY INFORMATION

WARNING:

This item contains small parts which can be swallowed by children and pets. Keep children and pets away during assembly.

To avoid danger of suffocation, always keep plastic bags away from children and pets.

We recommend that you assemble this unit on a carpeted floor to avoid scratches.

We do not recommend the use of power tools for assembly as this could damage the unit. Only use manual tools.

CARE INSTRUCTIONS

Wipe regularly with clean water and a damp, clean, soft white cloth

General cleaning can be done as needed with a mild detergent and water solution. Always rinse with clean water and dry

For heavy soiling, dampen a soft white cloth or soft bristle brush. Use care as scrubbing can damage the surface

More difficult stains can be treated, but this should be occasional, not daily, cleaning

ANY cleaning solution used must be removed with clean water and a clean white cloth

Cleaning residue left on the material can cause it to dry out and crack, or affect the colour

PRE ASSEMBLY INSTRUCTIONS

Identify all the parts and hardware.

Do not discard of the packaging until you have checked that you have all of the parts and hardware required.

Hardware package may have spare parts.

What you need



30
MINUTES

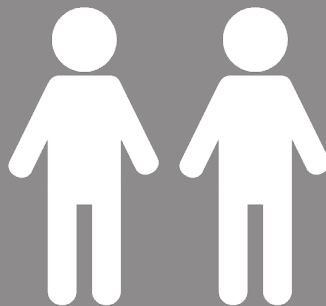

2
PEOPLE

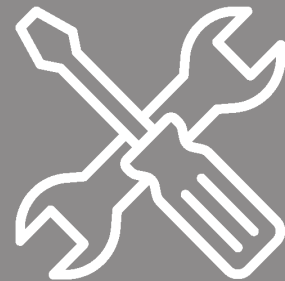

0
EXTRA TOOLS

HARDWARE DESCRIPTION

A



Qty 4

B

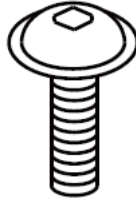

Qty 4

C



Qty 4

D



Qty 4

E

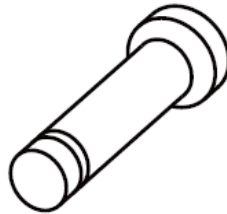

Qty 2

F



Qty 2

G



Qty 2

H



Qty 1

I

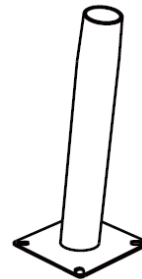

Qty 1

CHAIR ASSEMBLY

STEP 1

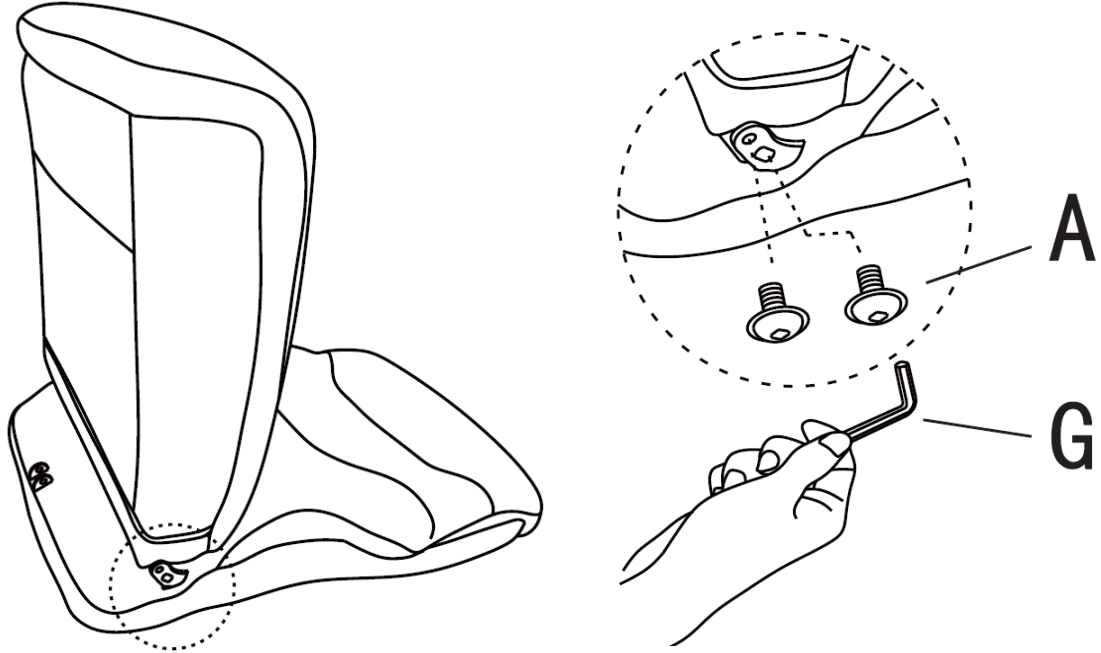

Tighten the screws halfway, do not fully install them.

STEP 2

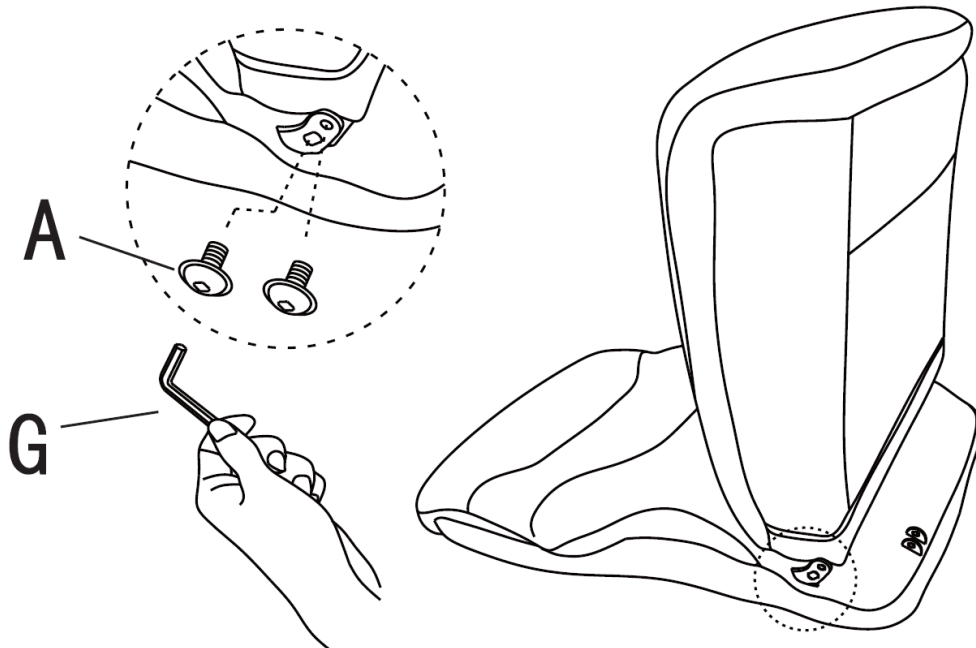

CHAIR ASSEMBLY

STEP 3

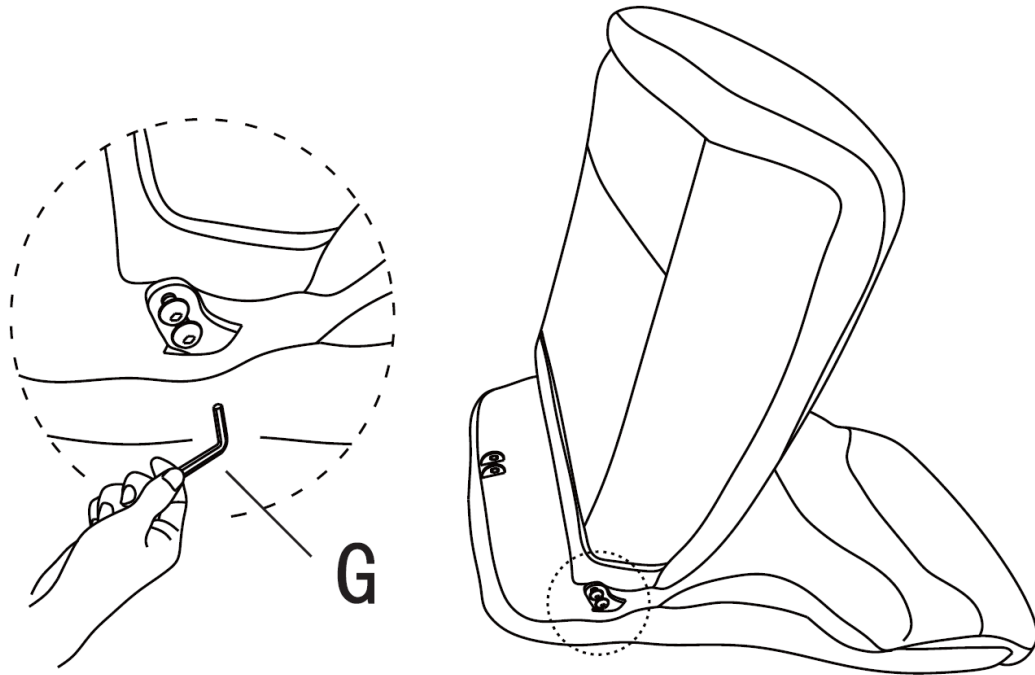

STEP 4

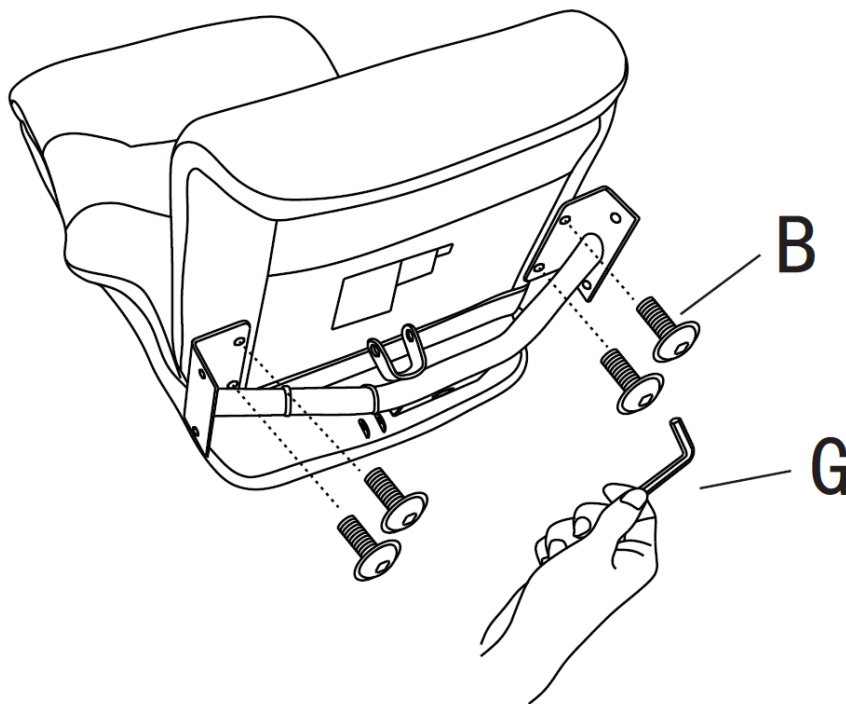

CHAIR ASSEMBLY

STEP 5

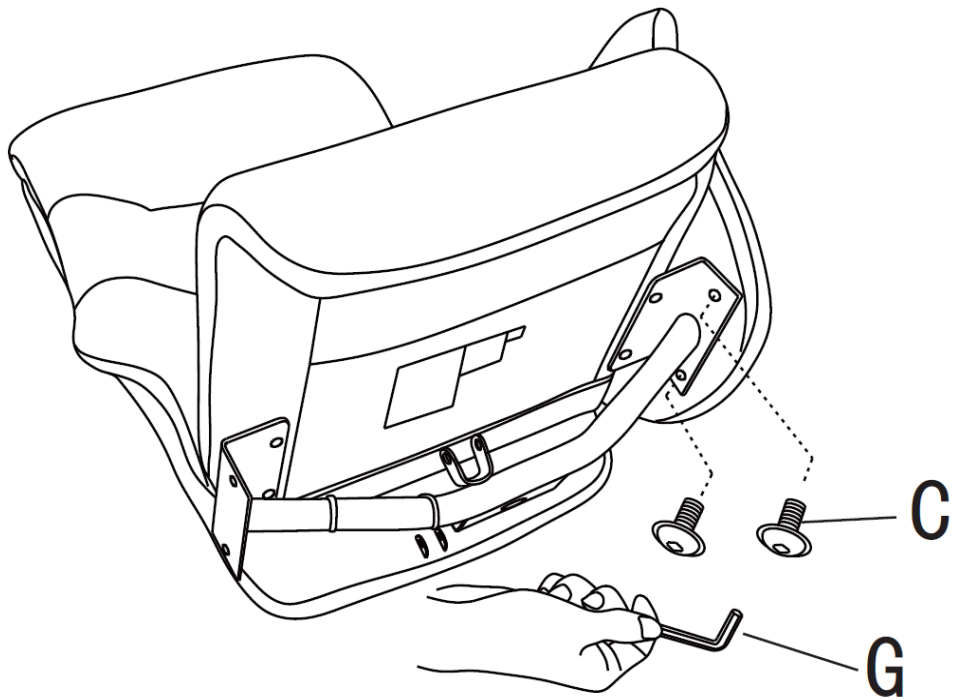

STEP 6

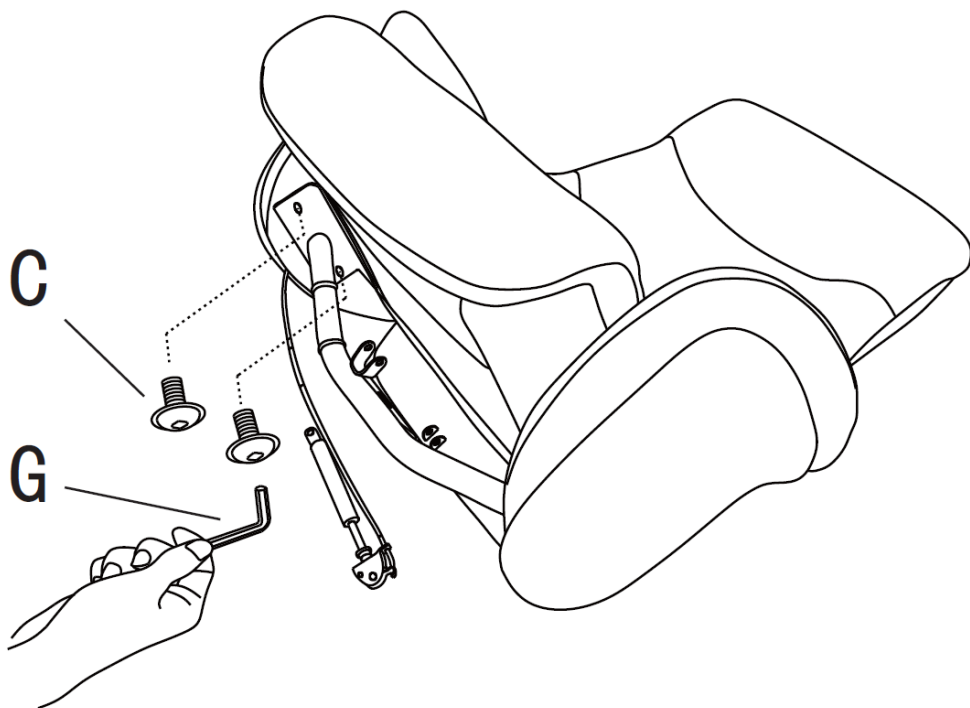

CHAIR ASSEMBLY

STEP 7

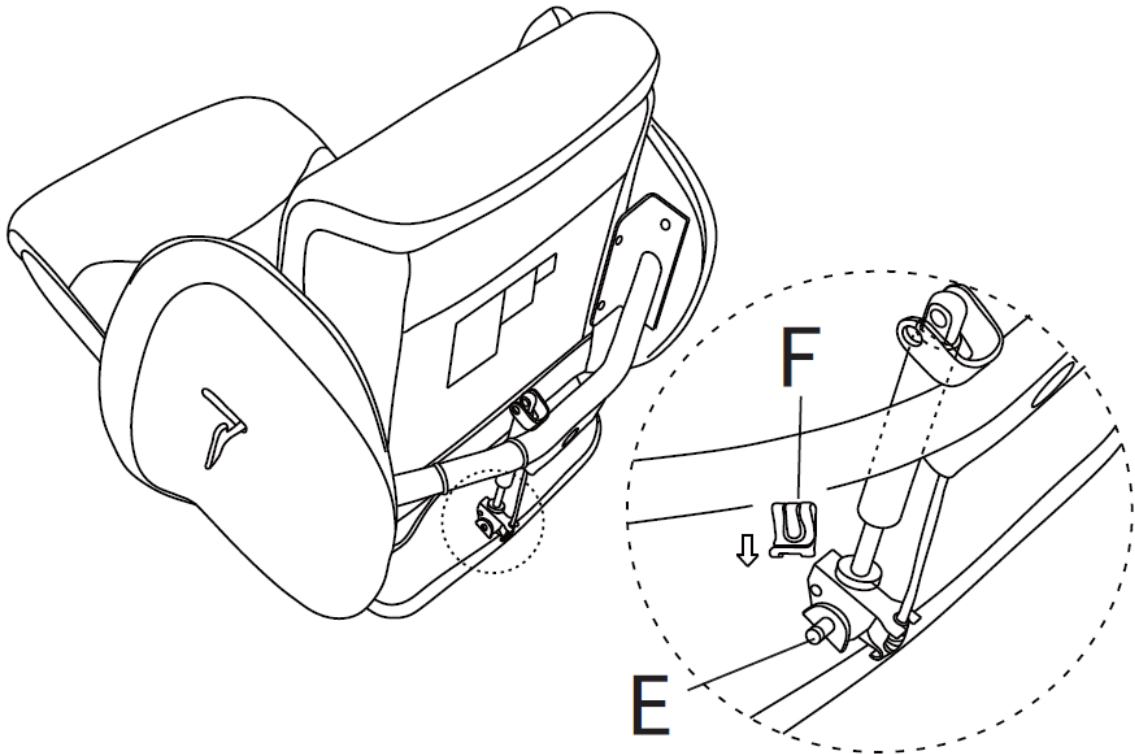

STEP 8

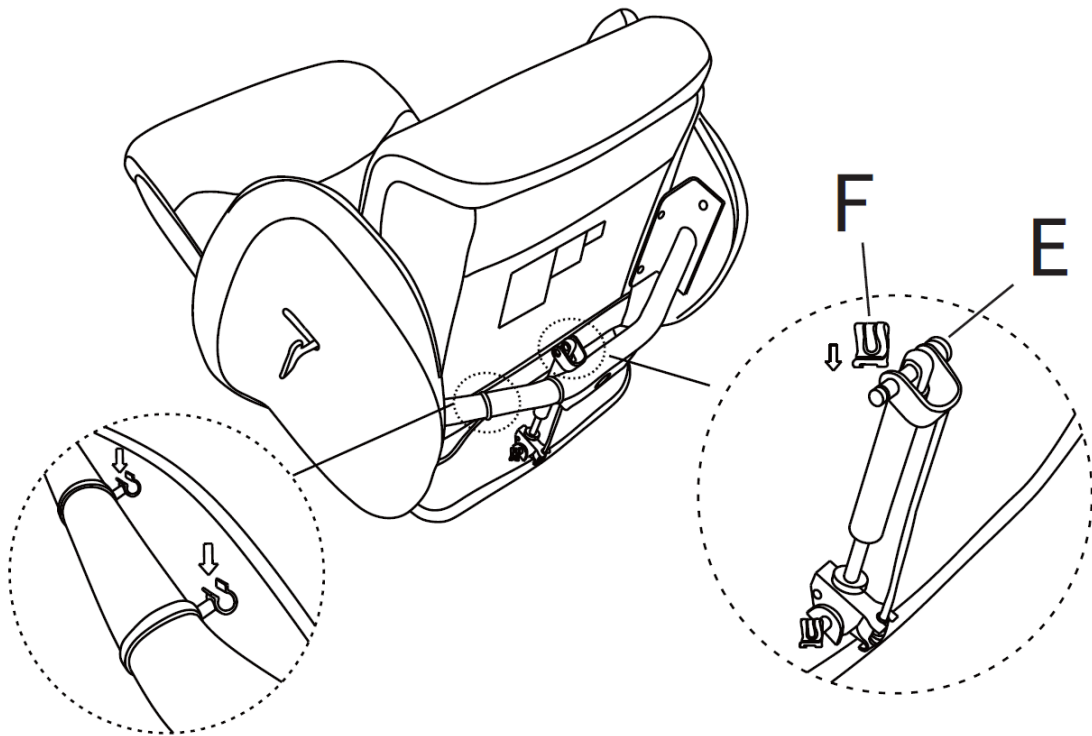

CHAIR ASSEMBLY

STEP 9

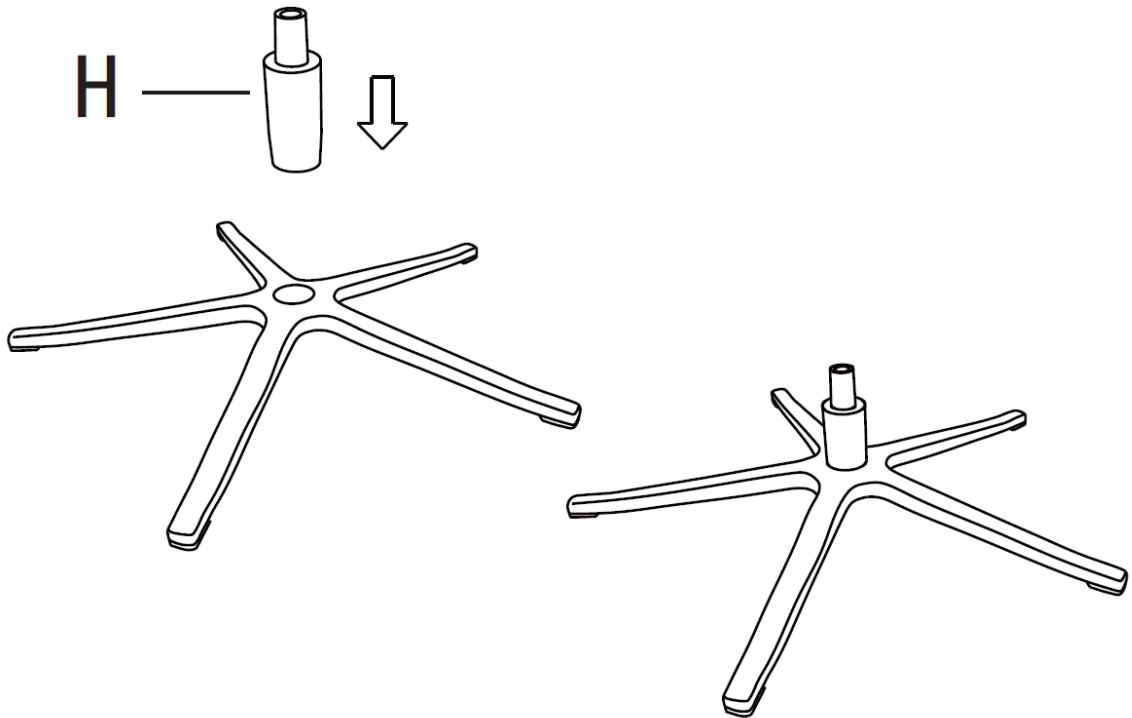

STEP 10

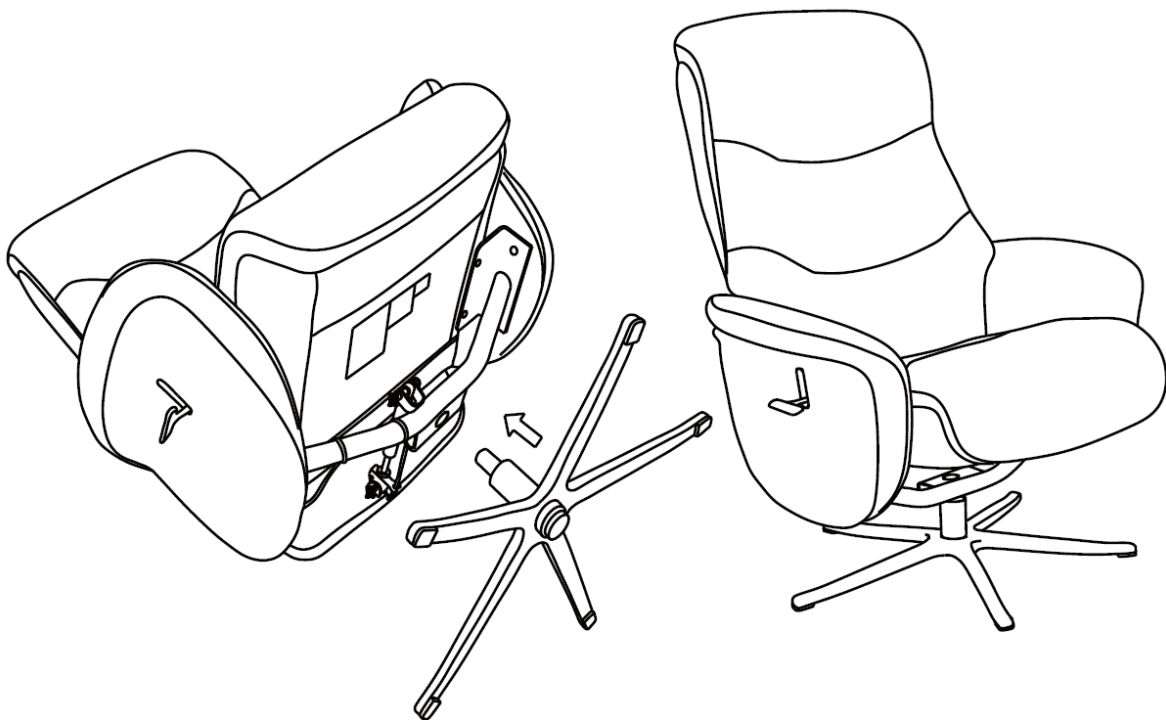

FOOTSTOOL ASSEMBLY

STEP 11

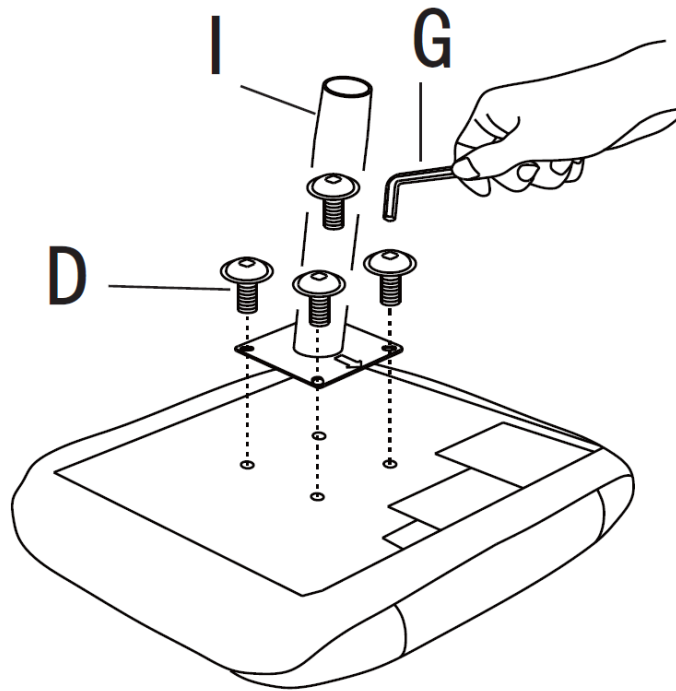

STEP 12

