



*The Industry's Best
Overall Value!*





The Industry's Best Overall Value!

Certification Icon Descriptions

- 
HACCP – Hazard Analysis Critical Control Points is a systematic approach to food safety. This approach utilizes seven principles and practices for analyzing a food process and determining the hazards within that process. (www.nal.usda.gov/fnic/foodborne/haccp/index.shtml)
- 
OSHA – The Occupational Safety and Health Administration works with employers and employees to create better, safer and healthier working environments in the United States. OSHA Sanitation Regulations (Standards - 29 CFR) state that any receptacle used for putrescible solid or liquid waste or refuse shall be so constructed that it does not leak and may be thoroughly cleaned and maintained in a sanitary condition. Such a receptacle shall be equipped with a solid, tight-fitting cover, unless it can be maintained in a sanitary condition without a cover. (www.osha.gov)
- 
DERMA-TEK®– This smooth surface, nonporous design is tough, durable and seamless – making it easy to clean and keep clean and provides a professional appearance. Plus, Derma-Tek® will not absorb chemicals, liquids or odors and will not rust, dent, chip or corrode.
- 
NSF – National Sanitation Foundation is an independent testing laboratory that lists products which meet their criteria for cleanability and sanitation in the areas of food contact and splash zone. Continental® manufactures products that meet the following NSF Standards: "Standard 2: Food Equipment" and "Standard 21:Thermoplastic Refuse Containers". (www.nsf.org)
- 
USDA – The United States Department of Agriculture sets regulations for the construction and material of equipment for use and/or contact with meat, poultry and dairy production and the hazards within that process. (www.usda.gov)
- 
FACTORY MUTUAL – FM is an independent testing agency that approves covered containers based on their ability to withstand an internal fire by the elimination/reduction of oxygen intake, to remain upright if tilted and to maintain shape and contain its contents throughout a specific temperature range. (www.fmglobal.com)
- 
UNDERWRITERS LABORATORY – The Continental® UL Classified Wastebaskets meet the UL performance criteria for open, non-metallic wastepaper containers and their ability to contain a fire. (www.ul.com)
- 
CALIFORNIA STATE FIRE MARSHAL – The State of California is often believed to be the most stringent of all the United States on their fire codes. Once a product has obtained UL and/or FM approval, they are submitted to California for acceptance. (<http://www.osfm.fire.ca.gov>)
- 
UN/DOT – The United Nations Economic & Social Council issues the UN Recommendations on the Transport of Dangerous Goods, which form the basis for most regional and national regulatory schemes. Following the UN Model, the DOT divides regulated hazardous materials into nine classes, some of which are further subdivided. Hazardous materials in transportation must be placarded and have specified packaging & labelling.
- 

Application Recommendations

These Symbols are Found with Mops, Brooms & Brushes

- 
INDUSTRIAL –
 Warehouses
 Factories
 Workshops
 Gas Stations
 Airports
 Maintenance Facilities
- 
HEALTHCARE –
 Hospitals
 Laboratories
 Nursing Homes
 Clinics
- 
RESILIENT FLOORS –
 Sports Facilities
 Entrance / Lobby Areas
 Office Settings
 Retail Stores
 Commercial Areas
- 
COMMERCIAL –
 Retail Stores
 Offices
 Malls
 Schools
 Universities
 Churches
 Public Facilities
- 
FOOD SERVICE –
 Dish & Pot Cleaning
 Counter Areas
 Sinks & Floors
 Equipment Maintenance
 Eating Areas
- 
CARPETED AREAS –
 Theatres / Auditoriums
 Entrance / Lobby Areas
 Office Settings
 Retail Stores
 Commercial Areas
- 
SCHOOLS –
 Grade Schools
 High Schools
 Colleges & Universities
 Boarding Schools
 Daycares



Represents products that provide sustainability advantages, either by their application or through the materials from which they are made.





The Industry's Best Overall Value!

Continental Commercial Products® is a long-time leading supplier of cleaning and food service equipment products. For over 50 years, the industry has relied on our brands to provide exceptional products at an outstanding value.



A large selection of plastic cleaning, floor care, food service equipment and receptacle products



The most diverse line of non-woven floor pad and hand pad products in the market today



The Wilen® brand of mops and microfiber offers a wide array of products for any cleaning situation and budget

A U.S. based manufacturer with worldwide distribution and service, we are widely recognized as the best overall value in the industry because we offer a unique combination of:

- A **Complete** line-up of products
- Flexible and willing to **Customize** for private label and OEM
- **Innovative** ideas that are functional and attractive
- **EARTHONE™** our suite of green cleaning products that support sustainability

Table of Contents

FLOOR CARE ... 3~74

Mop Buckets & Wringers
Wet Mops
Wet Mop Handles
Sponge Mops
Floor Finish Applicator
Touchless Mopping System
Microfiber Mops
Microfiber Mop Frames & Handles
Floor Squeegees
Floor Signs
Janitor Carts
Dust Mops
Microfiber Dust Mops
Dust Mop Handles & Frames
Floor Sweepers
Dust Pans
Brooms
Sweeps ~ Floor & Ground
Poles & Handles
Tool Hangers
Floor Pads
Utility Pads/holders & Stripping
Boots
Stone Care Floor Pads & Chemicals
Sand Screens & Pad Drivers
Carpet Bonnets & Microfiber
Floor Pads

MICROFIBER 13, 24~27, 39~41, 74, 85~87

Wet Mops ~ Specialty
Flat Mops
Flat Mop Frames & Handles
Dust Mops
Dust Mop Handles & Frames
Floor Pads
Cloths
Dusters

GENERAL CLEANING 75~93, 113~115

Hand Pads & Sponges
Brushes & Scrubs
Microfiber Cloths
Dusters
Wall Washers
Buckets
Sprayers & Pumps
Window Squeegees

TRASH CANS & RECEPTACLES 93~107

Receptacles, Lids & Accessories
Smoking Receptacles

RECYCLING ... 108~112

FOOD SERVICE EQUIPMENT 93~112, 115~121

Receptacles, Lids & Accessories
Carts & Accessories
Buss Tubs
Storage Shelves
Dunnage Racks
Ingredient Bins
Ice Bins
Scoops, Measures & Pitchers
Platform Trucks

MATERIAL HANDLING 117, 121~123

Platform Trucks
Tilt & Cube Trucks

RESTROOM ... 123~132

Odor Control
Urinal Mats & Screens
Restroom Cleaning Tools
Towel & Tissue Dispensers
Soap Dispensers
Infant Care



MOP BUCKETS & WRINGERS

Continental's comprehensive line of mop buckets and wringers are the industry standard for durable construction and quality made in the USA. Designed with efficiency and durability in mind, our innovative wringers maximize mechanical advantage, reduce worker strain and increase productivity. Our patented mop handle rest keeps the mop handle in place during transportation and storage.

WRINGERS

[A] SPLASH GUARD™ SIDE-PRESS WRINGER

Accommodates 12 to 32 ounce mops. Mop handle holder is molded into wringer front. Ergonomic handle design for leverage and comfort. Wringer nests in bucket for economic storage and shipment. Fits Continental® 26, 35 and 44 quart mop buckets.

[B] DOWN-PRESS WRINGER

Accommodates a variety of mops. Extended handle design for leverage and comfort. Utilizes gears to increase leverage and reduce fatigue. Wringer nests in bucket for economic storage and shipment. SW2 fits Continental® 26 quart mop buckets. SW7 fits 26, 35 and 44 quart mop buckets.

[C] INSTITUTIONAL WRINGER

Accommodates 12 to 32 ounce mops. Funnel-type wringer design uses no moving parts and is completely metal-free for improved safety. Fits Continental® 35 quart bucket.



Brand	Item #	Description	Case Pack	Case Weight	Case Cubic Ft.	Stock Item
Continental	SW12YW	Splash Guard™ Side-Press Wringer, Use with 12 - 32 oz. mops, Yellow	1	8.52 lbs.	1.440	✓
Continental	SW12BZ	Splash Guard™ Side-Press Wringer, Use with 12 - 32 oz. mops, Bronze	1	8.52 lbs.	1.440	✓
Continental	SW12BL	Splash Guard™ Side-Press Wringer, Use with 12 - 32 oz. mops, Blue	1	8.52 lbs.	1.440	✓
Continental	SW12GN	Splash Guard™ Side-Press Wringer, Use with 12 - 32 oz. mops, Green	1	8.52 lbs.	1.440	✓
Continental	SW2YW	Down-Press Wringer, Use with 8 - 16 oz. mops, Yellow	1	8.26 lbs.	1.450	✓
Continental	SW7YW	Down-Press Wringer, Use with 16 - 32 oz. mops, Yellow	1	10.58 lbs.	2.370	✓
Continental	SW7BZ	Down-Press Wringer, Use with 16 - 32 oz. mops, Bronze	1	10.58 lbs.	2.370	✓
Continental	SW7BL	Down-Press Wringer, Use with 16 - 32 oz. mops, Blue	1	10.58 lbs.	2.370	✓
Continental	SW9YW	Institutional Wringer, Use with 12 - 32 oz. mops, Yellow	1	4.00 lbs.	1.250	✓

MOP BUCKETS

[A] 26 QT. SPLASH GUARD™ MOP BUCKET

Includes plated steel bail, 3" non-marking grey casters, embossed graduations and universal "caution" logo. Fits Continental® SW2, SW7 and SW12 wringers.

[B] 35 QT. SPLASH GUARD™ MOP BUCKET

Includes plated steel bail, 3" non-marking grey casters, embossed graduations and universal "caution" logo. Fits Continental® SW7, SW9 and SW12 wringers.

[C] 44 QT. STRUCTOLENE® MOP BUCKET

Super durable Structolene® mop bucket with plated steel bail, 3" non-marking grey casters, embossed graduations and universal "caution" logo. Fits Continental® SW7 and SW12 wringers. *(this item does not have Derma-Tek® finish)*



Brand	Item #	Description	Case Pack	Case Weight	Case Cubic Ft.	Stock Item
Continental	226-3YW	26 qt. Splash Guard™ Mop Bucket, Yellow	1	13.00 lbs.	2.710	✓
Continental	226-3BZ	26 qt. Splash Guard™ Mop Bucket, Bronze	1	13.00 lbs.	2.710	✓
Continental	226-3BL	26 qt. Splash Guard™ Mop Bucket, Blue	1	13.00 lbs.	2.710	✓
Continental	226-3GN	26 qt. Splash Guard™ Mop Bucket, Green	1	13.00 lbs.	2.710	✓
Continental	335-3YW	35 qt. Splash Guard™ Mop Bucket, Yellow	1	16.00 lbs.	3.840	✓
Continental	335-3BZ	35 qt. Splash Guard™ Mop Bucket, Bronze	1	16.00 lbs.	3.840	✓
Continental	335-3BL	35 qt. Splash Guard™ Mop Bucket, Blue	1	16.00 lbs.	3.840	✓
Continental	404-3YW	44 qt. Structolene® Mop Bucket, Yellow	1	14.77 lbs.	3.320	✓



[D] INSTITUTIONAL WRINGER COMBO

The 35 quart Institutional Wringer Combo is available with 3" non-marking casters for improved maneuverability (335-39) or without casters (335-9) for areas where safety is a concern.

[E] UNIBODY® MOPPING SYSTEM

The 35 quart Unibody® is the most efficient side-press wringing system available. The one-piece design results in a positive transfer of force, removing more water per stroke. Includes self-draining spigot and sediment screen drain grate.

[F] 26 QT. SPLASH GUARD™ COMBO PACK

26 quart bucket with 3" non-marking grey casters and SW12 side-press wringer.



Brand	Item #	Description	Case Pack	Case Weight	Case Cubic Ft.	Stock Item
Continental	335-9YW	35 qt. Institutional Wringer Combo, Yellow	1	14.00 lbs.	3.950	
Continental	335-39YW	35 qt. Institutional Wringer Combo, Yellow	1	16.00 lbs.	4.630	✓
Continental	351YW	35 qt. Unibody Mopping System®, Yellow	1	22.68 lbs.	7.200	✓
Continental	351BZ	35 qt. Unibody Mopping System®, Bronze	1	22.68 lbs.	7.200	✓
Continental	351BL	35 qt. Unibody Mopping System®, Blue	1	22.68 lbs.	7.200	✓
Continental	351GN	35 qt. Unibody Mopping System®, Green	1	22.68 lbs.	7.200	✓
Continental	351RD	35 qt. Unibody Mopping System®, Red	1	22.68 lbs.	7.200	✓
Continental	226-312YW	26 qt. Splash Guard™ Combo Pack, Side-Press, Yellow	1	17.46 lbs.	2.780	✓
Continental	226-312BZ	26 qt. Splash Guard™ Combo Pack, Side-Press, Bronze	1	17.46 lbs.	2.780	✓
Continental	226-312BL	26 qt. Splash Guard™ Combo Pack, Side-Press, Blue	1	17.46 lbs.	2.780	✓
Continental	226-312GN	26 qt. Splash Guard™ Combo Pack, Side-Press, Green	1	17.46 lbs.	2.780	✓
Continental	226-312RD	26 qt. Splash Guard™ Combo Pack, Side-Press, Red	1	17.46 lbs.	2.780	✓



[A] 35 QT. SPLASH GUARD™ SIDE-PRESS COMBO PACK

35 quart bucket with 3" non-marking grey casters and SW12 side-press wringer.

[B] 35 QT. SPLASH GUARD™ DOWN-PRESS COMBO PACK

35 quart bucket with 3" non-marking grey casters and SW7 down-press wringer.

[C] 35 QT. SPLASH GUARD™ BACKSAVER COMBO PACK

35 quart self-draining bucket with 3" non-marking grey casters and SW12 side-press wringer. Includes self-draining spigot and sediment screen drain grate.

[D] 35 QT. SPLASH GUARD™ BACKSAVER COMBO PACK

35 quart self-draining bucket with 3" non-marking grey casters and SW7 down-press wringer. Includes self-draining spigot and sediment screen drain grate.

[E] SMOOTHLINE COMBO PACK

26 quart bucket with 3" non-marking grey casters. Choose between a SW2 down-press wringer or a SW6 side-press wringer for medium size mops.

[F] 44 QT. STRUCTOLENE® COMBO PACK

44 quart bucket with 3" non-marking grey casters, embossed graduations, universal "caution" logo and a SW7 down-press wringer.



Brand	Item #	Description	Case Pack	Case Weight	Case Cubic Ft.	Stock Item
Continental	335-312YW	35 qt. Splash Guard™ Combo Pack, Side-Press, Yellow	1	20.48 lbs.	4.410	✓
Continental	335-312BZ	35 qt. Splash Guard™ Combo Pack, Side-Press, Bronze	1	20.48 lbs.	4.410	✓
Continental	335-312BL	35 qt. Splash Guard™ Combo Pack, Side-Press, Blue	1	20.48 lbs.	4.410	✓
Continental	335-37YW	35 qt. Splash Guard™ Combo Pack, Down-Press, Yellow	1	28.00 lbs.	4.410	✓
Continental	335-37BZ	35 qt. Splash Guard™ Combo Pack, Down-Press, Bronze	1	28.00 lbs.	4.410	✓
Continental	335-37BL	35 qt. Splash Guard™ Combo Pack, Down-Press, Blue	1	28.00 lbs.	4.410	✓
Continental	336-312YW	35 qt. Splash Guard™ BackSaver Combo Pack, Side-Press, Yellow	1	20.88 lbs.	4.410	✓
Continental	336-37YW	35 qt. Splash Guard™ BackSaver Combo Pack, Down-Press, Yellow	1	29.50 lbs.	4.450	✓
Continental	266-32YW	26 qt. Smoothline Combo Pack, Down-Press, Yellow	1	10.50 lbs.	3.070	✓
Continental	266-36YW	26 qt. Smoothline Combo Pack, Side-Press, Yellow	1	10.50 lbs.	3.070	✓
Continental	404-37YW	44 qt. Structolene® Combo Pack, Down-Press, Yellow	1	26.11 lbs.	4.340	✓





WET MOPS

Wilen's comprehensive product line features a mop for any job and any budget. We offer a wide variety of yarns as well as new products to help users do their job more efficiently. From premium looped-end mops to economic cut-end mops, we have a mop for any application.

Choosing the Best Value in Wet Mops

YARN	ADVANTAGES	DISADVANTAGES	USES
Cotton	Good absorption and retention. Low initial cost.	Requires break-in. Lints and dries slow, promotes mildew and deterioration.	General use. Picking up liquids. Scrubbing.
Rayon	Quick absorption and release. Dries fast, mildew resistant. Cleaner yarn, lints less.	Shrinks when laundered. Less liquid retention.	Applying liquids (finishes, disinfectants).
Synthetic	Long staple fiber for superior tensile strength, no lint.	Higher cost. Poor absorption.	Rough surfaces.
Blends	Ideal balance for price, performance and durability. Synthetic fibers add durability and color.	May shrink (unless pre-shrunk).	Professionals who require better and longer lasting mops.

Use our [Looped-End Application Guide \(below\)](#), and our [Cut-End Application Guide \(page 7\)](#), to help select the right mop for your needs.

WET MOP APPLICATION GUIDE Looped-End Mops

Mop Type	Launderable Preshrunk		General Maintenance						Finish Mops			
	Fantastic™	*Hospital Pro M™	Super Crown™	JW Atomic™	JW Atomic™ Rayon	Jean Clean™	BullDog™	E-Line™	Smoothie™	Fast-Track™	JW Atomic™	E-Line™
Fiber	Synthetic	Synthetic Blend	Synthetic/Cotton	Synthetic/Cotton	Synthetic/Cotton	Recycled Denim	Synthetic/Cotton	Cotton	Nylon	Synthetic/Cotton	Synthetic/Cotton	Synthetic/Cotton
Size	S, M, L, XL	S, M, L, XL	S, M, L, XL	S, M, L, XL	S, M, L, XL	S, M, L, XL	S, M, L, XL	S, M, L, XL	S, M, L, XL	S, M, L, XL	S, M, L, XL	S, M, L, XL
Launderable	YES	YES	YES	YES	YES	YES	YES	YES	YES	YES	YES	YES
Application	Disinfecting	Disinfecting	Gen. Cleaning	Gen. Cleaning	Gen. Cleaning	Gen. Cleaning	Gen. Cleaning	Gen. Cleaning	Floor Finish	Floor Finish	Floor Finish	Floor Finish
Abrasion Resistance	5	5	5	4	4	4	3	2	5	4	3	2
Sustainability	100% recycled rayon & PET	67% RPET & recycled rayon	52% RPET & recycled rayon	32% RPET & recycled rayon	100% recycled rayon/RPET blend	100% reclaimed denim	50% reclaimed fibers	70% reclaimed fibers	50% reclaimed fibers	100% reclaimed rayon & PET	30% reclaimed rayon & PET	70% reclaimed fibers
Release	5	4	5	4	5	4	3	2	5	4	3	2
Retention	5	4	5	4	4	4	3	2	N/A	N/A	N/A	N/A
Healthcare	X	X	X	X	X				X	X		
Education	X	X	X	X	X	X	X	X		X	X	X
Industrial	X	X		X	X		X		X	X	X	X
Food Service						X	X	X				
Property Mgmt/BSC	X	X								X	X	X
Lodging	X	X				X			X	X	X	X

*Hospital Pro M™ is Antimicrobial

On the chart above, 5 represents the highest quality and 1 represents the lowest.

WET MOP APPLICATION GUIDE

Cut-End Mops

	Standard Mops for General Cleaning														
Mop Type	Go Go™ Blend	TexRay	Stinger	California 8-Ply	Industrial 8-Ply	Choice™ Cotton	Choice™ Rayon	T Rayon	Royal Go Go™ Blend	US Cotton Leader	P Rayon	E Cotton	Rayon Fan	Go Go™ Blend	US Cotton Leader
Fiber	Syn/Cot	Rayon/Poly	Cotton	Cotton	Cotton	Cotton	Rayon/Poly	Rayon/Poly	Syn/Cot	Cotton	Rayon/Poly	Cotton	Rayon/Poly	Syn/Cot	Cotton
Construction	Cut-End	Cut-End	Cut-End	Cut-End	Cut-End	Cut-End	Cut-End	Fan	Fan	Fan	Pinnacle	Pinnacle	Pinnacle Fan	Pinnacle Fan	Pinnacle Fan
Size	#/True Oz	#/True Oz	#/True Oz	True Oz	True Oz	Number	Number	True Oz	True Oz	True Oz	True Oz	True Oz	True Oz	True Oz	True Oz
Launderable	-	-	-	-	-	-	-	-	-	-	-	-	-	-	-
Abrasion Resistance	4	4	3	3	3	2	2	4	4	2	4	2	4	4	2
Absorption	4	4	3	3	3	2	2	4	4	2	4	2	4	4	2
Sustainability	30% RPET & recycled rayon	100% reclaimed rayon & PET	100% reclaimed cotton	100% reclaimed cotton	100% reclaimed cotton	100% reclaimed cotton	100% recycled rayon & PET	100% recycled rayon & PET	30% RPET & recycled rayon	100% reclaimed cotton	100% reclaimed rayon & PET	100% reclaimed cotton	100% recycled rayon & PET	30% RPET & recycled cotton	100% reclaimed cotton
Release	4	4	3	3	3	2	2	4	4	2	4	2	4	4	2
Retention	4	4	3	3	3	2	2	4	4	2	4	2	4	4	2
Education	X	X	X	X	X	X	X		X	X		X		X	X
Industrial	X	X	X	X	X	X	X	X	X	X	X	X	X	X	X
Food Service	X	X	X			X	X	X	X	X	X	X	X	X	X
Property Mgmt/BSC	X	X	X	X	X	X	X	X	X	X	X	X	X	X	X
Lodging	X	X	X	X	X	X	X	X	X	X	X	X	X	X	X

On the chart above, 5 represents the highest quality and 1 represents the lowest.

Yarn

Certain yarns do a specific task better than other yarns. That's why there is such a variety of mops. To get maximum efficiency and value from a wet mop, it is important to select the right yarn for the job.

Yarn Ply

Yarn ply indicates the number of strands twisted together to make a single yarn strand. More plies give added strength, though higher ply numbers do not necessarily mean higher quality yarn. More strands may add durability but they also decrease absorbency. It's generally recommended to choose a higher quality yarn than a high ply, low quality yarn.



Twist

A yarn's "twist" is a result of how tightly the fiber strands are wound together. While a tightly twisted yarn might be stronger and last longer, its absorbency may be decreased. Like yarn ply, the best value isn't determined by the yarn's twist, but by the type and quality of the yarn and the mop's construction. A mop with looped-end construction enables the yarn to have a loose twist while eliminating fraying.

ADDITIONAL CASE PACK OPTIONS



See our Price List for details.

MicroBlocker™

Locked into the yarn are fibers containing a registered antimicrobial additive. The additive protects the mop head from deterioration by inhibiting the growth of stain and odor causing bacteria, mold, mildew, and yeast in and on the mop head.

Sizes

A mop's size should be in relation to the job to be performed, the mop wringer being used and the user's size. Cut-end mops are sized by their approximate weight in ounces. Looped-end mops are sized by industry standards since they absorb and retain much more while also covering a greater surface area than a cut-end mop of comparable weight.

Cut-end

The cut-end is the standard, most popular and economical (initially) mop style. Cut-end mops fray and unravel, increasing the lint factor and leaving loose strands behind. In addition, without tailbands, cut-end mops cover less area per pass. Since cut-end mops cannot be laundered, they are often considered 'disposable' and thrown away when their useful life is over.

Looped-End

The looped-end mop is designed for superior performance and extended life. There are no ends to fray or unravel as the mop sweeps over the floor surface in a wide, even path. Looped-end mops can be laundered for longer life and cleaner appearance. The initial investment is soon compensated with lower replacement, reduced labor cost and increased performance.



Headbands

1 1/4" headbands are available for stirrup-type handles and are useful on finishing-type mops such as our FastTrack™ looped-end mop. The 5" width headbands are compatible with clamp and jaw-type handles. The synthetic mesh material provides non-abrasive scrubbing to help dislodge dirt and to allow quick drying of yarns. Abrasive scrubbing pads can also be included.

Narrow Headband

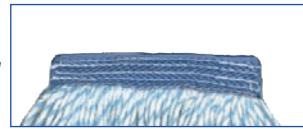

Wide Headband

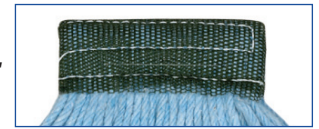

Looped-End Mops

LAUNDERABLE, PRE-SHRUNK MOPS

Our line of pre-shrunk, looped-end mops is designed to meet the needs of the health care industry and other users who launder mops. These mops may be laundered repeatedly while maintaining their clean appearance, low lint factor, absorbency and strength without shrinking. They also save money by outlasting incut-end mops up to eight times and reducing labor costs by up to one half!

Size	Equivalent Ounces	Band Color	Approximate Lbs./Dz.
Small	8-10	Red	10
Medium	16-20	Green	15
Large	24-32	Blue	18
X-Large	32-40	Yellow	23

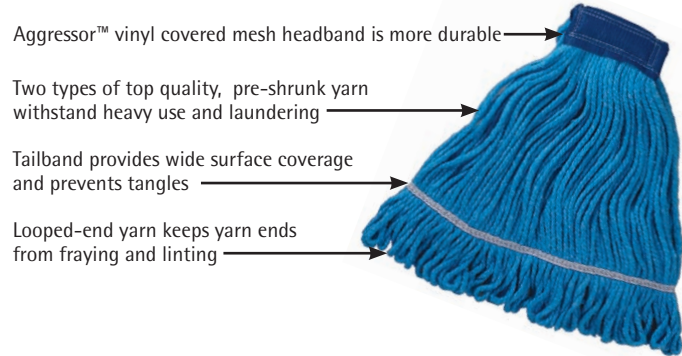

Sustainability

All Wilen® wet mops have green attributes that promote and enhance a comprehensive sustainability program. This is a clear differentiator. Many competitors feature only one family of mops with green attributes. You can be sure that Wilen wet mops are environmentally friendly and are constructed with a level of quality that ensures durability.

LOOPED-END WET MOPS

FANTASTIC™ **EARTHTONE™**

The Fantastic™ is constructed of a super absorbent, 4-ply conditioned rayon/synthetic yarn. Uniform twist and high-quality construction make it ideal for disinfecting and all purpose cleaning. Quick drying yarn resists the growth of mildew and bacteria.

Brand	5" Band Item #	1.25" Band Item #	Size	Yarn Color	Case Pack	Case Weight	Case Cubic Ft.	Stock Item
Wilen	A00601	A00611	Small	Blue	12	10.00 lbs.	1.290	✓
Wilen	A00602	A00612	Medium	Blue	12	15.00 lbs.	1.813	✓
Wilen	A00603	A00613	Large	Blue	12	18.00 lbs.	1.813	✓
Wilen	A00701	A00711	Small	Orange	12	10.00 lbs.	1.290	✓
Wilen	A00702	A00712	Medium	Orange	12	15.00 lbs.	1.813	✓
Wilen	A00703	A00713	Large	Orange	12	18.00 lbs.	1.813	✓
Wilen	A00901	A00911	Small	Green	12	10.00 lbs.	1.290	✓
Wilen	A00902	A00912	Medium	Green	12	15.00 lbs.	1.813	✓
Wilen	A00903	A00913	Large	Green	12	18.00 lbs.	1.813	✓

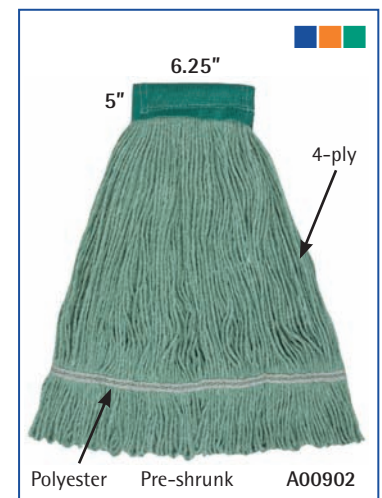

LOOPED-END WET MOPS

[A] HOSPITAL PRO M™ - ANTIMICROBIAL



Designed for the demanding needs of the healthcare industry, the Hospital Pro M™ stands up to tough use and heavy washing. Its high-quality, integrated blend of cotton/ rayon/synthetic fibers ensures durability and absorbency. Also ideal for all-purpose cleaning.

Brand	5" Band Item #	1.25" Band Item #	Size	Yarn Color	Case Pack	Case Weight	Case Cubic Ft.	Stock Item
Wilen	A01101	A01111	Small	White	12	10.00 lbs.	1.290	✓
Wilen	A01102	A01112	Medium	White	12	15.00 lbs.	1.813	✓
Wilen	A01103	A01113	Large	White	12	18.00 lbs.	1.813	✓
Wilen	A01201	A01211	Small	Blue	12	10.00 lbs.	1.290	✓
Wilen	A01202	A01212	Medium	Blue	12	15.00 lbs.	1.813	✓
Wilen	A01203	A01213	Large	Blue	12	18.00 lbs.	1.813	✓
Wilen	A01301	A01311	Small	Orange	12	10.00 lbs.	1.290	✓
Wilen	A01302	A01312	Medium	Orange	12	15.00 lbs.	1.813	✓
Wilen	A01303	A01313	Large	Orange	12	18.00 lbs.	1.813	✓
Wilen	A01501	A01511	Small	Green	12	10.00 lbs.	1.290	✓
Wilen	A01502	A01512	Medium	Green	12	15.00 lbs.	1.813	✓
Wilen	A01503	A01513	Large	Green	12	18.00 lbs.	1.813	✓

[B] SUPER CROWN™



High-grade, multi-layered, blended cotton/rayon/synthetic yarn provides good absorption and durability for this top of the line general maintenance mop. Excellent for general cleaning. This mop is not pre-shrunk - launder with care.

Brand	5" Band Item #	1.25" Band Item #	Size	Yarn Color	Case Pack	Case Weight	Case Cubic Ft.	Stock Item
Wilen	A02001	A02011	Small	Natural	12	10.00 lbs.	1.290	✓
Wilen	A02002	A02012	Medium	Natural	12	15.00 lbs.	1.813	✓
Wilen	A02003	A02013	Large	Natural	12	18.00 lbs.	1.813	✓
Wilen	A02004	A02014	X-Large	Natural	12	23.00 lbs.	1.828	✓
Wilen	A02101	A02111	Small	Blue	12	10.00 lbs.	1.290	✓
Wilen	A02102	A02112	Medium	Blue	12	15.00 lbs.	1.813	✓
Wilen	A02103	A02113	Large	Blue	12	18.00 lbs.	1.813	✓
Wilen	A02104	A02114	X-Large	Blue	12	23.00 lbs.	1.828	✓
Wilen	A02201	A02211	Small	Orange	12	10.00 lbs.	1.290	✓
Wilen	A02202	A02212	Medium	Orange	12	15.00 lbs.	1.813	✓
Wilen	A02203	A02213	Large	Orange	12	18.00 lbs.	1.813	✓
Wilen	A02204	A02214	X-Large	Orange	12	23.00 lbs.	1.828	✓
Wilen	A02401	A02411	Small	Green	12	10.00 lbs.	1.290	✓
Wilen	A02402	A02412	Medium	Green	12	15.00 lbs.	1.813	✓
Wilen	A02403	A02413	Large	Green	12	18.00 lbs.	1.813	✓
Wilen	A02404	A02414	X-Large	Green	12	23.00 lbs.	1.828	✓

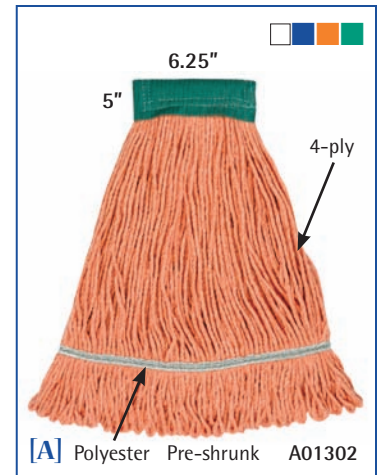

[A] Polyester Pre-shrunk A01302



[A] Polyester Pre-shrunk A01512



[B] Polyester A02002



[B] Polyester A02112

LOOPED-END WET MOPS

[A] J.W. ATOMIC LOOP™ EARTHONE™

This economical cotton/rayon/synthetic blend mop cleans two to three times the area with up to six times the life of a conventional cut-end mop.

Brand	5" Band Item #	1.25" Band Item #	Size	Yarn Color	Case Pack	Case Weight	Case Cubic Ft.	Stock Item
Wilco	A02501	A02511	Small	Natural	12	10.00 lbs.	1.290	✓
Wilco	A02502	A02512	Medium	Natural	12	15.00 lbs.	1.813	✓
Wilco	A02503	A02513	Large	Natural	12	18.00 lbs.	1.813	✓
Wilco	A02504	A02514	X-Large	Natural	12	23.00 lbs.	1.828	✓
Wilco	A02601	A02611	Small	Blue	12	10.00 lbs.	1.290	✓
Wilco	A02602	A02612	Medium	Blue	12	15.00 lbs.	1.813	✓
Wilco	A02603	A02613	Large	Blue	12	18.00 lbs.	1.813	✓
Wilco	A02604	A02614	X-Large	Blue	12	23.00 lbs.	1.828	✓
Wilco	A02701	A02711	Small	Orange	12	10.00 lbs.	1.290	✓
Wilco	A02702	A02712	Medium	Orange	12	15.00 lbs.	1.813	✓
Wilco	A02703	A02713	Large	Orange	12	18.00 lbs.	1.813	✓
Wilco	A02704	A02714	X-Large	Orange	12	23.00 lbs.	1.828	✓
Wilco	A02801	A02811	Small	Green	12	10.00 lbs.	1.290	✓
Wilco	A02802	A02812	Medium	Green	12	15.00 lbs.	1.813	✓
Wilco	A02803	A02813	Large	Green	12	18.00 lbs.	1.813	✓
Wilco	A02804	A02814	X-Large	Green	12	23.00 lbs.	1.828	✓

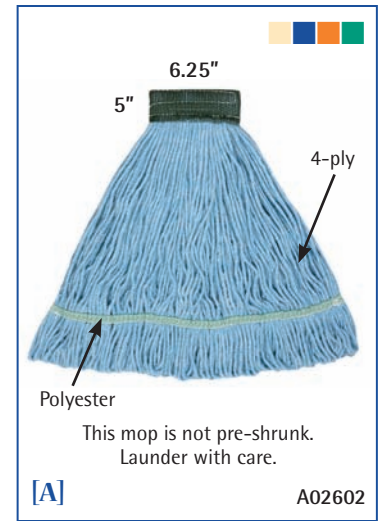

[B] J.W. ATOMIC RAYON LOOP™ EARTHONE™

This economical rayon/synthetic is for the application of chemicals and is perfect for floor finishing.

Brand	5" Band Item #	1.25" Band Item #	Size	Yarn Color	Case Pack	Case Weight	Case Cubic Ft.	Stock Item
Wilco	A02901	A02911	Small	White	12	10.00 lbs.	1.290	✓
Wilco	A02902	A02912	Medium	White	12	15.00 lbs.	1.813	✓
Wilco	A02903	A02913	Large	White	12	18.00 lbs.	1.813	✓
Wilco	A02904	A02914	X-Large	White	12	23.00 lbs.	1.828	✓

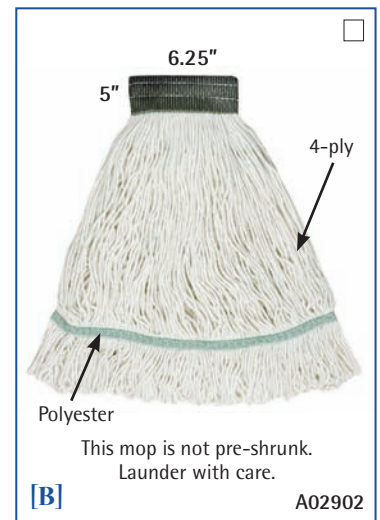

[C] JEAN CLEAN™ EARTHONE™

Constructed of reconditioned denim and other textile materials, Jean Clean™ is more durable and absorbent than cotton blended yarn with no break-in period required. Looped-end cotton/polyester yarn prevents fraying and linting.

Brand	5" Band Item #	1.25" Band Item #	Size	Yarn Color	Case Pack	Case Weight	Case Cubic Ft.	Stock Item
Wilco	A03001	A03011	Small	Blue	12	10.00 lbs.	1.290	✓
Wilco	A03002	A03012	Medium	Blue	12	15.00 lbs.	1.813	✓
Wilco	A03003	A03013	Large	Blue	12	18.00 lbs.	1.813	✓



LOOPED-END WET MOPS

[A] BULLDOG MOP™



EARTHTONE™

In looped-end mops, the Bulldog™ is the economical choice. This is the perfect mop to choose to upgrade from a cut-end mop to a looped-end mop, and is ideal for general purpose cleaning.

Brand	5" Band Item #	1.25" Band Item #	Size	Yarn Color	Case Pack	Case Weight	Case Cubic Ft.	Stock Item
Wilco	A05001	A05011	Small	Natural	12	10.00 lbs.	1.290	✓
Wilco	A05002	A05012	Medium	Natural	12	15.00 lbs.	1.813	✓
Wilco	A05003	A05013	Large	Natural	12	18.00 lbs.	1.813	✓
Wilco	A05101	A05111	Small	Blue	12	10.00 lbs.	1.290	✓
Wilco	A05102	A05112	Medium	Blue	12	15.00 lbs.	1.813	✓
Wilco	A05103	A05113	Large	Blue	12	18.00 lbs.	1.813	✓



ECONOMY LINE WET MOPS

[B] GENERAL PURPOSE LOOPED-END



EARTHTONE™

This commercial cotton mop is perfect for general purpose cleaning. Sewn English/Spanish tailband.

Brand	5" Band Item #	1.25" Band Item #	Size	Yarn Color	Case Pack	Case Weight	Case Cubic Ft.	Stock Item
Wilco	A11101	A11111	Small	Natural	12	10.00 lbs.	1.290	✓
Wilco	A11102	A11112	Medium	Natural	12	15.00 lbs.	1.813	✓
Wilco	A11103	A11113	Large	Natural	12	18.00 lbs.	1.813	✓
Wilco	A11104	A11114	X-Large	Natural	12	23.00 lbs.	1.828	✓
Wilco	A11201	A11211	Small	Blue	12	10.00 lbs.	1.290	✓
Wilco	A11202	A11212	Medium	Blue	12	15.00 lbs.	1.813	✓
Wilco	A11203	A11213	Large	Blue	12	18.00 lbs.	1.813	✓
Wilco	A11204	A11214	X-Large	Blue	12	23.00 lbs.	1.828	✓
Wilco	A11501	A11511	Small	Orange	12	10.00 lbs.	1.290	✓
Wilco	A11502	A11512	Medium	Orange	12	15.00 lbs.	1.813	✓
Wilco	A11503	A11513	Large	Orange	12	18.00 lbs.	1.813	✓
Wilco	A11504	A11514	X-Large	Orange	12	23.00 lbs.	1.828	✓
Wilco	A11301	A11311	Small	Green	12	10.00 lbs.	1.290	✓
Wilco	A11302	A11312	Medium	Green	12	15.00 lbs.	1.813	✓
Wilco	A11303	A11313	Large	Green	12	18.00 lbs.	1.813	✓
Wilco	A11304	A11314	X-Large	Green	12	23.00 lbs.	1.828	✓

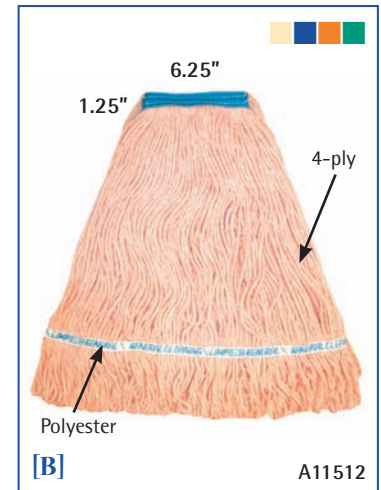

[C] SUPER LOOPER™



EARTHTONE™

Designed for easy access into tight spaces. The Super Looper™ mop goes where conventional mops can't and saves you money by using standard threaded handles. It also saves labor by using blended looped-end yarn and a tailband to cover more surface area and soak up to three times more liquid than cut-end mops while outlasting them over eight times. Perfect for restaurants, hotels, restrooms, offices, classrooms, or anywhere a small mop is needed.

Brand	Item #	Size	Yarn Color	Case Pack	Case Weight	Case Cubic Ft.	Stock Item
Wilco	A03151	Small	Blue	12	8.00 lbs.	0.920	✓



Accepts threaded handles only. Found on page 51



SPECIALTY MOPS

[A] ROUGH RIDER™ EARTHTONE™

New generation wet mop features knitted strands that out-perform and outlast conventional wet mops. Rough Rider™ stands up to any floor surface including stone, concrete, raised and textured.

Premium/Lint Free - Durable nylon/synthetic material is highly absorbent. Ideal for healthcare, as well as concrete and raised floor surfaces. Low lint material also makes it ideal for electronic, graphic and optical environments.

Utility Fan With Welting Cord - Very absorbent cotton strands make the Utility Fan great for food service and other general maintenance uses. Economical mop delivers high performance for maximum mopping efficiency.

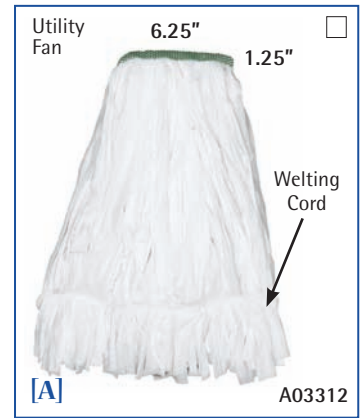

Brand	5" Band Lint Free Item #	1.25" Band Lint Free Item #	5" Band Utility Fan Item #	1.25" Band Utility Fan Item #	Size	Yarn Color	Case Pack	Case Weight	Case Cubic Ft.	Stock Item
Wilen	A03202	A03212	A03302	A03312	Medium	White	12	15.00 lbs.	1.813	✓
Wilen	A03203	A03213	A03303	A03313	Large	White	12	18.00 lbs.	1.813	✓

[B] ABSORBO™ ROUGH SURFACE EARTHTONE™

This mop is perfect for concrete, raised tile, or rubber floors. It is three times more absorbent than conventional 100% cotton mops, and is lint free. Durable 100% cotton non-woven material is biodegradable.

Brand	5" Band Item #	1.25" Band Item #	Size	Yarn Color	Case Pack	Case Weight	Case Cubic Ft.	Stock Item
Wilen	A42302	- - -	Medium	White	12	15.00 lbs.	1.813	✓
Wilen	A42303	- - -	Large	White	12	18.00 lbs.	1.813	✓



[C] ACTIONPRO® EARTHTONE™

Ideal for stripping applications where the application time is limited, including retail, healthcare and education. Constructed of a reclaimed cellulose/polyester blend. Three times more absorbent than cotton and requires no break-in period.

Brand	Heavy-Duty 5" Band Item #	Standard 1.25" Band Item #	Size	Yarn Color	Case Pack	Case Weight	Case Cubic Ft.	Stock Item
Wilen	A956001	A956011	Small	White	12	5.00 lbs.	0.660	✓
Wilen	A956002	A956022	Medium	White	12	6.50 lbs.	1.356	✓
Wilen	A956003	A956033	Large	White	12	8.00 lbs.	1.356	✓



[D] MUSCLEPRO® EARTHTONE™

Highly absorbent cut-end mop with high impact plastic head that is fused with scrubbing bristles. Non-woven yarn material requires no break-in period and holds seven times its weight in liquid. Excellent for scrubbing grouted tile floors!

Brand	Item #	Size	Yarn Color	Case Pack	Case Weight	Case Cubic Ft.	Stock Item
Wilen	A956101	Small	White	12	5.40 lbs.	2.040	✓
Wilen	A956102	Medium	White	12	6.90 lbs.	2.040	✓
Wilen	A956103	Large	White	12	8.04 lbs.	2.040	✓



SPECIALTY MOPS

[A] MUSCLE MOP®



EARTHTONE™

Cotton cut-end mop with a high impact plastic head fused with scrubbing bristles. This innovative mop combines two tools into one, saving money in labor while reducing the risk of slip and fall injuries.

Brand	Item #	Size	Yarn Color	Case Pack	Case Weight	Case Cubic Ft.	Stock Item
Wilco	A401920	20 oz.	Natural	12	16.00 lbs.	1.700	✓



[B] SUPER SORB TUBE MOPS



EARTHTONE™

This looped-end, wet mop is environmentally friendly because it requires less chemicals than cotton/blend yarn mops. Microfiber material offers excellent absorbency, as well as superior scrubbing power. Mops can be laundered 400 times. Mop features a 5" wide headband to be used with "jaws" type handles.

Brand	Item #	Size	Color	Case Pack	Case Weight	Case Cubic Ft.	Stock Item
Wilco	A10001	11 oz. / Sm	Blue	12	9.00 lbs.	0.984	✓
Wilco	A10002	14 oz. / Med	Blue	12	11.50 lbs.	1.813	✓
Wilco	A10003	18 oz. / Lg	Blue	12	14.50 lbs.	1.799	✓
Wilco	A10101	11 oz. / Sm	Green	12	9.00 lbs.	0.984	✓
Wilco	A10102	14 oz. / Med	Green	12	11.50 lbs.	1.813	✓
Wilco	A10103	18 oz. / Lg	Green	12	14.50 lbs.	1.799	✓



[C] DURALOOP WET MOP



EARTHTONE™

This mop will pick up twice as much liquid as a standard blended, looped-end mop. Can be used as a wax application mop. Use with Jaws type wet mop handles. Launder up to 150 times.

Brand	Item #	Size	Color	Case Pack	Case Weight	Case Cubic Ft.	Stock Item
Wilco	A09002	Medium	Blue	12	11.00 lbs.	0.970	✓
Wilco	A09003	Large	Blue	12	16.00 lbs.	1.260	✓



FLOOR FINISH WET MOPS

LIQUID APPLICATION MOPS

When it's time to apply finishes and sealers, use a tool designed for the job. Our conventional style finish mops provide a smooth, clean finish while outlasting conventional cut-end mops over eight times. For larger finish jobs, the Floor Finish Flat Mop provides performance and economy. You'll get a better finish with less effort.

[D] SMOOTHIE™ FINISH



EARTHTONE™

Worker fatigue can be reduced by 20 to 25% due to the incredibly smooth application of the Smoothie™. This 100% nylon 2-ply yarn holds finish with surface tension, not by absorption. As the mop is moved along the floor surface, finish is released more evenly and completely.

Brand	1.25" Band Item #	Size	Yarn Color	Case Pack	Case Weight	Case Cubic Ft.	Stock Item
Wilco	A03612	Medium	White	12	15.00 lbs.	1.813	✓
Wilco	A03613	Large	White	12	18.00 lbs.	1.813	✓

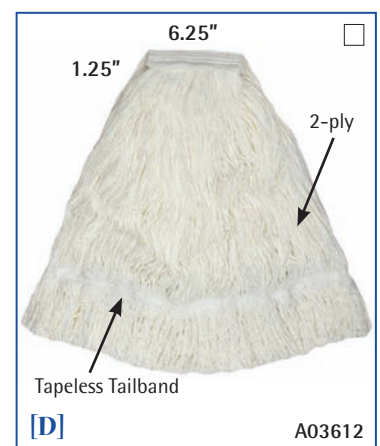

FLOOR FINISH WET MOPS

[A] FASTTRACK™ FINISH EARTHTONE™

Upgrade your finish with FastTrack™, the durable, looped-end wet mop especially designed for applying finish. Constructed of a 6-ply, high-wet modulus rayon blend that provides quick, controlled liquid release for finishing and disinfecting. Blue and white "candy cane" striped yarn keeps mop looking new.

Brand	5" Band Item #	1.25" Band Item #	Size	Yarn Color	Case Pack	Case Weight	Case Cubic Ft.	Stock Item
Wilen	A03501	A03511	Small	Blue/White	12	10.00 lbs.	1.290	✓
Wilen	A03502	A03512	Medium	Blue/White	12	15.00 lbs.	1.813	✓
Wilen	A03503	A03513	Large	Blue/White	12	18.00 lbs.	1.813	✓



[B] J.W. ATOMIC™ FINISH EARTHTONE™

100% synthetic yarn designed for applying finish. Blue and white "candy cane" striped yarn keeps mop looking new.

Brand	5" Band Item #	1.25" Band Item #	Size	Yarn Color	Case Pack	Case Weight	Case Cubic Ft.	Stock Item
Wilen	A03701	A03711	Small	Blue/White	12	10.00 lbs.	1.290	✓
Wilen	A03702	A03712	Medium	Blue/White	12	15.00 lbs.	1.813	✓
Wilen	A03703	A03713	Large	Blue/White	12	18.00 lbs.	1.813	✓
Wilen	A03704	A03714	X-Large	Blue/White	12	23.00 lbs.	2.828	✓

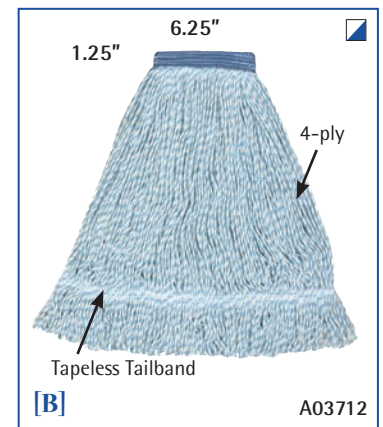

[C] E-LINE FINISH EARTHTONE™

Our most economical looped-end finish mop is constructed of a durable, 4-ply rayon blend yarn that releases more liquid for a faster, smoother finish than possible with a conventional mop. Also ideal for applying sealers and disinfectants. Blue and white "candy cane" striped yarn keeps mop looking new.

Brand	5" Band Item #	1.25" Band Item #	Size	Yarn Color	Case Pack	Case Weight	Case Cubic Ft.	Stock Item
Wilen	A11401	A11411	Small	Blue/White	12	10.00 lbs.	1.290	✓
Wilen	A11402	A11412	Medium	Blue/White	12	15.00 lbs.	1.813	✓
Wilen	A11403	A11413	Large	Blue/White	12	18.00 lbs.	1.813	✓
Wilen	A11404	A11414	X-Large	Blue/White	12	23.00 lbs.	2.828	✓

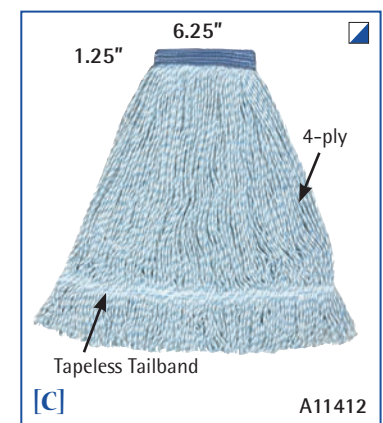

[D] FLOOR FINISH FLAT MOP EARTHTONE™

For larger finish jobs, the Floor Finish Flat Mop provides performance and economy. This looped-end mop is constructed of a high-wet modulus rayon blend yarn that provides quick, controlled liquid release. Rayon finish mop features a mesh backing that allows you to pour finish directly into mop for better dispersal of fluids.

Brand	Item #	Size	Yarn Color	Case Pack	Case Weight	Case Cubic Ft.	Stock Item
Wilen	B601018	18" x 5"	Blue/White	12	12.00 lbs.	1.290	✓
Wilen	B601024	24" x 5"	Blue/White	12	12.00 lbs.	1.812	✓

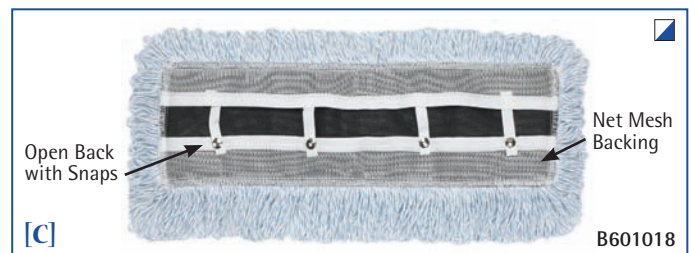

CUT-END WET MOPS
INDUSTRY STANDARD CUT-END MOPS



We offer the widest variety of cut-end mops in the industry. Whether you need an economical, disposable mop for extra dirty jobs or a durable 8-ply mop for rough floors, there's a mop for the job. All mops feature high quality materials and superior construction.



Brand	Industrial 8-Ply Cotton 5" Band Item #	Industrial 8-Ply Cotton 1.25" Band Item #	California 8-Ply Cotton 5" Band Item #	California 8-Ply Cotton 1.25" Band Item #	Size	Yarn Color	Case Pack	Case Weight	Case Cubic Ft.	Stock Item
Wilen	A405016	A405116	A410016	A410116	16 oz.	Natural	12	12.00 lbs.	1.813	✓
Wilen	A405020	A405120	---	---	20 oz.	Natural	12	15.00 lbs.	1.813	✓
Wilen	A405024	A405124	A410024	A410124	24 oz.	Natural	12	18.00 lbs.	1.813	✓
Wilen	A405032	A405132	A410032	A410132	32 oz.	Natural	12	24.00 lbs.	1.813	✓



Brand	GoGoBlend Natural 4-Ply 5" Band Item #	GoGoBlend Natural 4-Ply 1.25" Band Item #	Stinger 4-Ply Cotton 5" Band Item #	Stinger 4-Ply Cotton 1.25" Band Item #	Texray 4-Ply Rayon 5" Band Item #	Texray 4-Ply Rayon 1.25" Band Item #	Size	Yarn Color	Case Pack	Case Weight	Case Cubic Ft.	Stock Item
Wilen	---	---	A401012	A401112	A414012	A414112	12 oz.	Natural Cotton/White Rayon	12	9.00 lbs.	1.290	✓
Wilen	A419016	A419116	A401016	A401116	A414016	A414116	16 oz.	Natural Cotton/White Rayon	12	12.00 lbs.	1.813	✓
Wilen	A419020	A419120	A401020	A401120	A414020	A414120	20 oz.	Natural Cotton/White Rayon	12	15.00 lbs.	1.813	✓
Wilen	A419024	A419124	A401024	A401124	A414024	A414124	24 oz.	Natural Cotton/White Rayon	12	18.00 lbs.	1.813	✓
Wilen	A419032	A419132	A401032	A401132	A414032	A414132	32 oz.	Natural Cotton/White Rayon	12	24.00 lbs.	1.813	✓
Wilen	---	---	A901012	A901112	A911012	A911112	#16	Natural Cotton/White Rayon	12	9.00 lbs.	1.290	✓
Wilen	---	---	A902016	A902116	A912016	A912116	#20	Natural Cotton/White Rayon	12	12.00 lbs.	1.290	✓
Wilen	---	---	A903020	A903120	A913020	A913120	#24	Natural Cotton/White Rayon	12	15.00 lbs.	2.265	✓
Wilen	---	---	A904028	A904128	A914028	A914128	#32	Natural Cotton/White Rayon	12	21.00 lbs.	2.265	✓



This low-end, cut-end mop is great for economical general cleaning and disinfecting.

Brand	Cotton 5" Band Item #	Cotton 1.25" Band Item #	Rayon 5" Band Item #	Rayon 1.25" Band Item #	Size	Yarn Color	Case Pack	Case Weight	Case Cubic Ft.	Stock Item
Wilen	A927010	A927110	A928010	A928110	#16	Natural Cotton/White Rayon	12	7.00 lbs.	0.808	✓
Wilen	A937014	A937114	A938014	A938114	#20	Natural Cotton/White Rayon	12	10.00 lbs.	0.534	✓
Wilen	A947018	A947118	A948018	A948118	#24	Natural Cotton/White Rayon	12	13.00 lbs.	1.506	✓
Wilen	A957024	A957124	A958024	A958124	#32	Natural Cotton/White Rayon	12	18.00 lbs.	2.001	✓



CUT-END FAN MOPS

STANDARD MOP WITH TAILBAND

[A] CUT-END FAN EARTHTONE™

Our labor saving fan mops feature four-sewn tailbands that keep yarn strands fanned out for greater coverage and less tangles. Listed below are our most popular yarns, from cotton for all-purpose use, to rayon for economical finish applications. All mops are 4-ply except for the U.S. Cotton Leader Fan which is 8-ply.

Brand	GoGo Blend Natural Fan 5" Band Item #	GoGo Blend Natural Fan 1.25" Band Item #	T Rayon Fan 1.25" Band Item #	US/Cotton Leader Fan 1.25" Band Item #	Size	Yarn Color	Case Pack	Case Weight	Case Cubic Ft.	Stock Item
Wilco	A202016	A202116	A203116	A207116	16 oz.	Natural Cotton/White Rayon	12	12.00 lbs.	1.813	✓
Wilco	A202020	A202120	A203120	A207120	20 oz.	Natural Cotton/White Rayon	12	15.00 lbs.	1.813	✓
Wilco	A202024	A202124	A203124	A207124	24 oz.	Natural Cotton/White Rayon	12	18.00 lbs.	1.813	✓
Wilco	A202032	A202132	A203132	A207132	32 oz.	Natural Cotton/White Rayon	12	24.00 lbs.	1.813	✓



GO GO™ CUT-END MOPS

Low cost, high quality cut-end mops feature colored yarn to keep mop looking new. With no break-in required, these absorbent, tough mops go to work right away. Great for all-purpose cleaning.

[B] GO GO™ CUT-END (Use with Pinnacle™ Handles) EARTHTONE™

Colored Go Go™ Cut-End - Wide or narrow headbands accommodate any type handle. Colored yarn helps maintain clean appearance.

Colored Go Go™ Pinnacle - These No Marr Pinnacle mops are designed to lie flat on the floor and feature colored yarn to keep mops looking new. Screw connector attachment provides fast changing of heads.

Brand	5" Band Item #	1.25" Band Item #	No Marr Pinnacle Item #	Size	Yarn Color	Case Pack	Case Weight	Case Cubic Ft.	Stock Item
Wilco	A427016	A427116	A427316	#16	Blue	12	9.00 lbs.	1.290	✓
Wilco	A427024	A427124	A427324	#24	Blue	12	15.00 lbs.	2.265	✓
Wilco	A427032	A427132	A427332	#32	Blue	12	18.00 lbs.	2.825	✓
Wilco	A430016	A430116	A430316	16 oz.	Blue	12	12.00 lbs.	1.813	✓
Wilco	A430020	A430120	A430320	20 oz.	Blue	12	15.00 lbs.	1.813	✓
Wilco	A430024	A430124	A430324	24 oz.	Blue	12	18.00 lbs.	1.813	✓
Wilco	A430032	A430132	A430332	32 oz.	Blue	12	24.00 lbs.	1.813	✓
Wilco	A428016	A428116	---	#16	Green	12	9.00 lbs.	1.290	✓
Wilco	A428024	A428124	---	#24	Green	12	15.00 lbs.	2.265	✓
Wilco	A428032	A428132	---	#32	Green	12	18.00 lbs.	2.825	✓
Wilco	A431016	A431116	---	16 oz.	Green	12	12.00 lbs.	1.813	✓
Wilco	A431020	A431120	---	20 oz.	Green	12	15.00 lbs.	1.813	✓
Wilco	A431024	A431124	---	24 oz.	Green	12	18.00 lbs.	1.813	✓
Wilco	A431032	A431132	---	32 oz.	Green	12	24.00 lbs.	1.813	✓

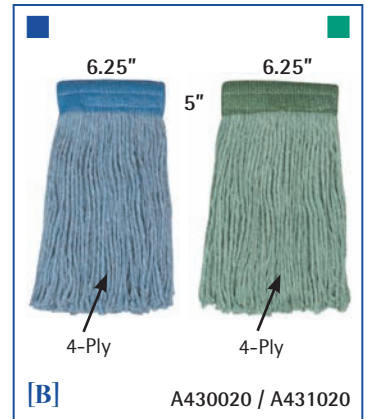

PINNACLE™ CUT-END MOPS
THE MOP THAT LIES FLAT

[A] PINNACLE™ (Use with Pinnacle™ Handles)



Pinnacle™ wet mops lie flat on the floor and utilize a screw-on attachment that provides fast, efficient changing of mop heads. No Marr style eliminates marring of floors, baseboards and furniture, and is standard.

Brand	E Cotton No Marr Pinnacle™ Item #	P Rayon No Marr Pinnacle™ Item #	Size	Yarn Color	Case Pack	Case Weight	Case Cubic Ft.	Stock Item
Wilco	A503316	A504316	16 oz.	Natural Cotton/White Rayon	12	12.00 lbs.	1.813	✓
Wilco	A503320	A504320	20 oz.	Natural Cotton/White Rayon	12	15.00 lbs.	1.813	✓
Wilco	A503324	A504324	24 oz.	Natural Cotton/White Rayon	12	18.00 lbs.	1.813	✓
Wilco	A503332	A504332	32 oz.	Natural Cotton/White Rayon	12	24.00 lbs.	1.813	✓



[B] PINNACLE™ FAN (Use with Pinnacle™ Handles)



Same as the previous Pinnacle™ mops, except for the addition of a tailband to keep yarn spread and minimize tangles and loose strands. No Marr style standard.

Brand	Leader/ US Cotton No Marr Pinnacle™ Item #	Rayon Fan No Marr Pinnacle™ Item #	Go Go Blend No Marr Pinnacle™ Item #	Size	Yarn Color	Case Pack	Case Weight	Case Cubic Ft.	Stock Item
Wilco	A551316	A552316	A555316	16 oz.	Natural Cotton/White Rayon	12	12.00 lbs.	1.813	✓
Wilco	A551320	A552320	A555320	20 oz.	Natural Cotton/White Rayon	12	15.00 lbs.	1.813	✓
Wilco	A551324	A552324	A555324	24 oz.	Natural Cotton/White Rayon	12	18.00 lbs.	1.813	✓
Wilco	A551332	A552332	A555332	32 oz.	Natural Cotton/White Rayon	12	24.00 lbs.	1.813	✓



YACHT MOPS
THE POPULAR MOP ON A STICK

[C] YACHT MOP



Cord tied yarn is securely attached to a wood handle and provides long service. Choose either cotton or rayon yarn. Ideal for infrequent users, such as small stores, offices and garages. Sizes 12 and 16 ounce are standard with 15/16" x 48" handle. Sizes 24 and 32 ounce are standard with 1 1/8" x 54" handle.

Brand	Leader/ US Cotton Item #	Rayon Item #	Size	Yarn Color	Case Pack	Case Weight	Case Cubic Ft.	Stock Item
Wilco	A605012	A606012	12 oz.	Natural Cotton/White Rayon	6	18.00 lbs.	3.761	✓
Wilco	A605016	A606016	16 oz.	Natural Cotton/White Rayon	6	20.00 lbs.	3.819	✓
Wilco	A605024	A606024	24 oz.	Natural Cotton/White Rayon	6	30.00 lbs.	6.250	✓
Wilco	A605032	A606032	32 oz.	Natural Cotton/White Rayon	6	36.00 lbs.	7.432	✓



WET MOP ACCESSORIES

[D] LAUNDRY NET



100% polyester net with drawstring lock closure. Helps prevent tangles and damage when laundering mops. Also ideal for laundering other items.

Brand	Item #	Size	Color	Case Pack	Case Weight	Case Cubic Ft.	Stock Item
Wilco	A80803	24" x 36"	White	12	10.00 lbs.	1.290	✓





WET MOP HANDLES

Our line of mop handles is as comprehensive as our line of mops. Choose from our wide array of materials, styles and colors ... all designed with quality and ease of use in mind.

Use Stirrup Style mop handles with Narrow Band mops; Use Jaws Style mop handles with Wide Band mops.

[A] COLOR GUARD® WET MOP HANDLE

The U.S. Department of Agriculture, through its Hazard Analysis Critical Control Points (HACCP) has recognized the need for a sanitation program to prevent cross-contamination. Our Color Guard® handles are offered in four different colors in both #94 Speed Change™ and SuperJaws™ head styles. All handles are 1" x 60" fiberglass.



Brand	#94 Speed Change™ Item #	Super Jaws™ Item #	Handle Color	Case Pack	Case Weight	Case Cubic Ft.	Stock Item
Wilco	A70342	A70642	Blue	12	22.00 lbs.	2.682	✓
Wilco	A70352	A70652	Red	12	22.00 lbs.	2.682	✓
Wilco	A70362	A70662	Green	12	22.00 lbs.	2.682	✓
Wilco	A70312	A70612	Yellow	12	22.00 lbs.	2.682	✓

HACCP Color-coded handles prevent cross-contamination.



#94 Speed Change™ is recommended for narrow head bands.

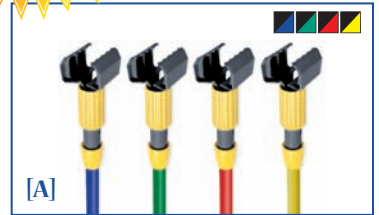

Super Jaws™ is recommended for wide head bands.

[B] LOAD 'N LOCK™

High-impact plastic head features a side release gate for fast and easy mop changes. Mops simply slide off without having to touch them. Recommended for narrow headbands.

Brand	Item #	Handle Type	Handle Size	Case Pack	Case Weight	Case Cubic Ft.	Stock Item
Wilco	A71612	Fiberglass	1" x 60"	12	19.00 lbs.	2.682	✓



[B] A71612



[C] A70312

[C] #94 SPEED CHANGE™

High-impact plastic head features a side release gate for fast and easy mop changes. Mops simply slide off without having to touch them. Features an easy to use thumb-wheel adjustment. Recommended for narrow headbands.

Brand	Item #	Handle Type	Handle Size	Case Pack	Case Weight	Case Cubic Ft.	Stock Item
Wilco	A70302	Wood	1" x 60"	12	22.00 lbs.	2.682	✓
Wilco	A70312	Fiberglass	1" x 60"	12	22.00 lbs.	2.682	✓
Wilco	A70322	Vinyl Coated Steel	1" x 60"	12	22.00 lbs.	2.682	✓

[A] BREAK-A-WAY MOP HANDLE



Easy side loading and hands free unloading without touching a soiled mop. Large thumb wheel controls tension. All plastic construction will not mark surfaces. Serrated corner for gripping a scour pad. Ideal for mops with a narrow head band.

Brand	Item #	Handle Type	Handle Size	Case Pack	Case Weight	Case Cubic Ft.	Stock Item
Continental	605	Wood	1 1/8" x 56 1/2"	12	22.88 lbs.	2.682	✓
Continental	607	Fiberglass	1 1/8" x 54 1/8"	12	18.36 lbs.	2.682	✓
Continental	608	Fiberglass	1 1/8" x 60"	12	18.30 lbs.	2.682	✓

[B] NIGHT STICK MOP HANDLE



Non-corrosive, lightweight plastic with easy thumbwheel action for quick release of mop head. Ideal for mops with a narrow head band.

Brand	Item #	Handle Type	Handle Size	Case Pack	Case Weight	Case Cubic Ft.	Stock Item
Continental	596	Fiberglass	1 1/8" x 64"	12	18.12 lbs.	2.760	✓
Continental	598	Wood	1 1/8" x 61 1/2"	12	20.40 lbs.	2.760	✓

[C] SUPERJAWS™



Extra durable nylon construction assures long life for this jaw style handle. Recommended for wide headbands.

Brand	Item #	Handle Type	Handle Size	Case Pack	Case Weight	Case Cubic Ft.	Stock Item
Wilco	A70602	Wood	1 5/16" x 60"	12	22.00 lbs.	2.506	✓
Wilco	A70612	Fiberglass	1" x 60"	12	22.00 lbs.	2.506	✓
Wilco	A70622	Vinyl Coated Steel	1" x 60"	12	22.00 lbs.	2.506	✓

[D] JAWS MOP HANDLE



Extra durable plastic construction assures long product life. Ideal for mops with a wide head band.

Brand	Item #	Handle Type	Handle Size	Case Pack	Case Weight	Case Cubic Ft.	Stock Item
Continental	600	Fiberglass	1 1/8" x 54 1/2"	12	15.84 lbs.	2.760	✓
Continental	601	Fiberglass	1 1/8" x 60"	12	16.80 lbs.	2.760	✓

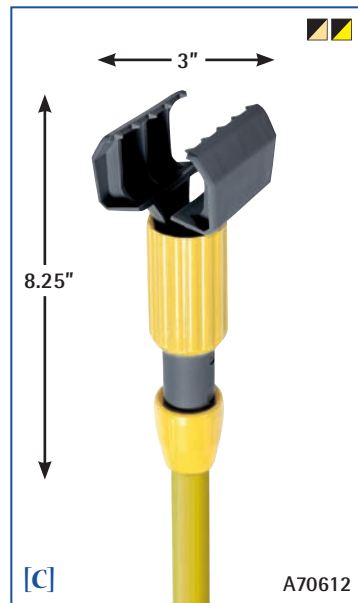

[A] METAL STIRRUP QUICK CHANGE™

Same as the regular Stirrup except for a quick release bar (yoke) to facilitate fast mop changes. This popular, heavy-duty handle provides durability with efficiency. Recommended for narrow headbands.

Brand	Item #	Handle Type	Handle Size	Case Pack	Case Weight	Case Cubic Ft.	Stock Item
Wilco	A70902	Wood	1 1/8" x 60"	12	30.00 lbs.	2.506	✓
Continental	772	Steel	1" x 63"	12	32.40 lbs.	2.760	✓

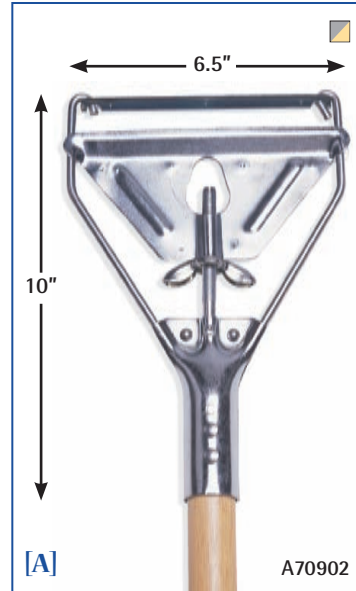

[B] SPRING YOKE MOP HANDLE

Zinc plated steel head with wood or fiberglass handle. Quick mop loading and removal without touching soiled mop head. Ideal for mops with a narrow head band.

Brand	Item #	Handle Type	Handle Size	Case Pack	Case Weight	Case Cubic Ft.	Stock Item
Continental	571	Wood	1 1/8" x 60"	12	32.16 lbs.	2.760	✓
Continental	573	Fiberglass	1" x 60"	12	20.52 lbs.	2.760	✓

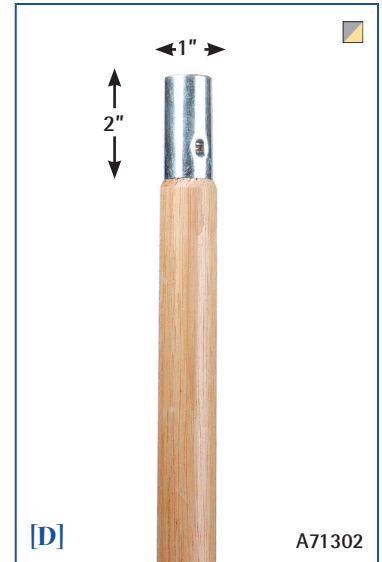
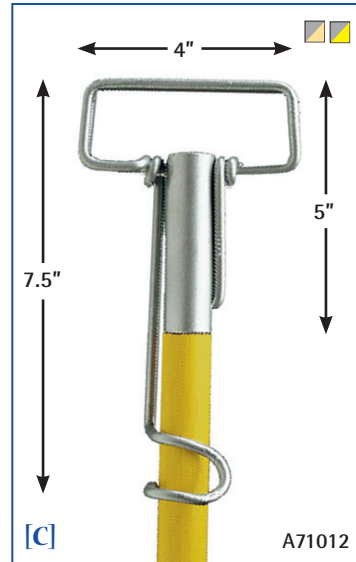

[C] SUREGRIP™

4" wide plated head. Features an adjustable spring clamp and is rust resistant. Jaws open wide to accommodate any size mop. Stainless Steel Suregrip™ features push-button, break apart handle to allow for sterilization in small autoclave units. Recommended for wide headbands.

Brand	Item #	Handle Type	Handle Size	Case Pack	Case Weight	Case Cubic Ft.	Stock Item
Wilco	A71002	Wood	1 1/8" x 60"	12	28.00 lbs.	2.506	✓
Wilco	A71012	Fiberglass	1" x 60"	12	28.00 lbs.	2.506	✓
Wilco	A71022	Vinyl/Alum.	1" x 60"	12	28.00 lbs.	2.506	✓

[D] PINNACLE™

Metal threaded connector is countersunk into wood handle for fast and efficient mop head changes. For use with Pinnacle mops.

Brand	Item #	Handle Type	Handle Size	Case Pack	Case Weight	Case Cubic Ft.	Stock Item
Wilco	A71302	Wood	1 1/8" x 60"	12	18.00 lbs.	1.843	✓

SPONGE MOPS

These versatile sponge mops are ideal for applying disinfectant and sanitizer or general maintenance. Durable handles and high quality sponge refills ensure long-lasting operation.

SPONGE MOPS

[A] COMBO SPONGE MOP



This highly absorbent sponge is excellent for maintenance and sanitizer applications. Steel painted handle with hanger handle grip. 12" wide.

Brand	Item #	Item	Length	Case Pack	Case Weight	Case Cubic Ft.	Stock Item
Continental	6012	Complete	55 ¹³ / ₁₆ "	12	38.88 lbs.	3.600	✓
Continental	6112	Refill	12"	12	8.16 lbs.	1.440	✓



[B] ROLLER CELLULOSE SPONGE



This durable sponge mop features an extra wide cellulose sponge for maximum absorption and a convenient handle mounted lever for efficient roller wringing. Wringing is easy without having to bend over. Plated metal construction and plastic rollers assure long service. Cellulose sponge refills are also available. Sponge measures 12" wide.

Brand	Item #	Item	Length	Case Pack	Case Weight	Case Cubic Ft.	Stock Item
Wilco	B805000	Complete	55"	6	14.00 lbs.	2.734	✓
Wilco	B806000	Refill	12"	6	6.00 lbs.	2.482	✓

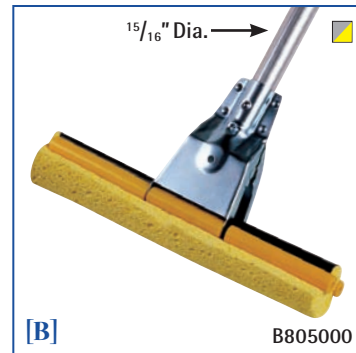

[C] PVA SPONGE MOP



Polyvinyl Alcohol is incredibly absorbent and durable. Rippled sponge provides excellent scrubbing action for cleaning debris. Hand operated wring lever. Durable, long-lasting plastic housing with smooth, effortless wringing operation. Sponge is blue.

Brand	Item #	Item	Length	Case Pack	Case Weight	Case Cubic Ft.	Stock Item
Wilco	B809000	Complete	36" - 53"	6	14.00 lbs.	1.995	✓
Wilco	B809500	Refill	10"	12	6.00 lbs.	0.600	✓



FLOOR FINISH APPLICATOR

Even the best floor finish will provide poor results when applied with an inadequate tool. That is why we offer these professional finishing products. Whether you are applying finish, disinfectant, sealer or any other liquid, you will not only get much better results, but also unmatched labor savings.

[A] WAX-O-MATIC®

This professional finish application machine applies both water and solvent based fluids including finishes, sealers, urethanes, restorers and disinfectants, quickly, easily and smoothly. The straight line method, with built-in edge feathering, covers many times the area of conventional methods—without the spills, drips and baseboard splashes! Push button dispensing and replaceable wick pads provide complete control of finish thickness. The Wax-O-Matic® covers about 30,000 square feet per hour and comes with a three gallon tank. Wick pads and manual included. Warrantied for one full year. Some assembly required. Comes standard with one set (two pads) of Ultra Refills.

Brand	Item #	Description	Case Pack	Case Weight	Case Cubic Ft.	Stock Item
Wilco	B608004	Complete	1	14.00 lbs.	1.995	✓
Wilco	B610000	Extra Heavy Refill (Lambswool)	2	1.00 lb.	0.376	✓
Wilco	B611000	Ultra Refill (Velour)	2	1.00 lb.	0.376	✓

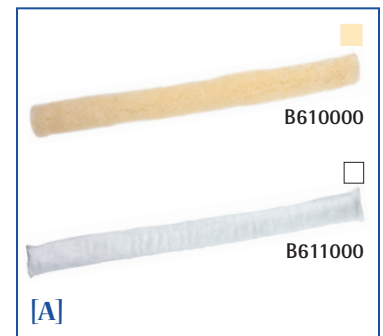
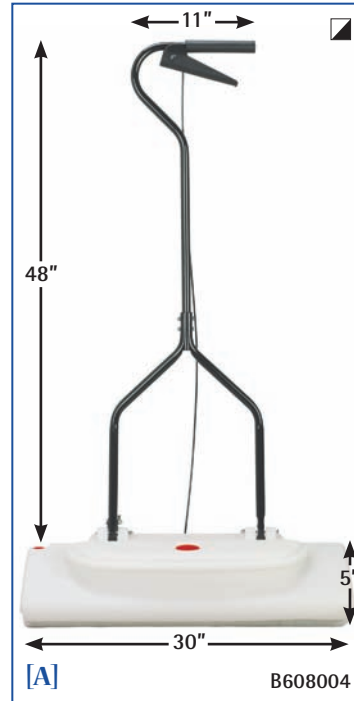

[B] FLOOR FINISH FLAT MOP

For larger finish jobs, the Floor Finish Flat Mop provides performance and economy. This looped-end mop is constructed of a high-wet modulus rayon blend yarn that provides quick, controlled liquid release. Rayon finish mop features a mesh backing that allows you to pour finish directly into mop for better dispersal of fluids.

Brand	Item #	Size	Yarn Color	Case Pack	Case Weight	Case Cubic Ft.	Stock Item
Wilco	B601018	18" x 5"	Blue/White	12	12.00 lbs.	1.290	✓
Wilco	B601024	24" x 5"	Blue/White	12	12.00 lbs.	1.812	✓

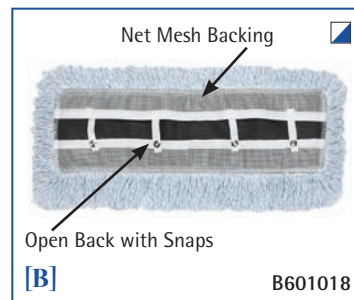

[C] SOLUTION SRAVER

Solution Saver conserves floor care chemicals by allowing the use of small amounts of chemical and eliminating chemical contamination. High-impact plastic container has a sloped "wring ramp" to help remove excess liquid from applicator. Solution Saver has a three gallon capacity and features 2" locking casters, carrying handles and a pour spout with cap for easy removal of liquid.

Brand	Item #	Color	Case Pack	Case Weight	Case Cubic Ft.	Stock Item
Wilco	B603000	Yellow	12	12.00 lbs.	1.290	✓

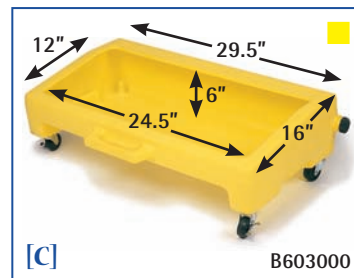



TOUCHLESS MOPPING SYSTEM

ErgoWorx® is the industry's most innovative, truly touch-less mopping system and is ideally suited for Microfiber mopping. Its patented design eliminates the need to handle soiled mops and breaks the chain of cross contamination. Designed to reduce water and chemical consumption, it makes for a perfect solution to the challenges associated with Green Cleaning. And, its ergonomic benefits improve worker safety by reducing physical stress.

ERGOWORX® TOUCHLESS CLEANING SYSTEM



Continental Commercial Products® has always been focused on developing more effective ways to clean. We've taken the advanced science of Microfiber and created a complete "SYSTEM" which will significantly reduce the risk of cross-contamination when cleaning and disinfecting rooms.

Microfiber cleaning truly offers many health and safety benefits along with tangible cost benefits. This makes the ErgoWorx® Touchless Cleaning System from Continental Commercial Products® the clear choice for your Microfiber cleaning needs.

ERGOWORX® TROLLEY

The newest addition to the ErgoWorx® system, the Microfiber Trolley. This trolley can be added to the SYS-5 to create a mobile cleaning system that is both compact and efficient. The 3" non-marking, all swivel casters provide finger touch mobility, ideal for tight hallways and small rooms. The MFT-5 is designed to accommodate common cleaning tools including a wet floor sign, microflex duster, wipes and RTU trigger sprayer bottles.

ERGOWORX® LAUNDRY NET BAG

Made of 100% polyester net with drawstring lock closure. This bag is perfect for discarding into and transporting dirty Microfiber refills to the laundry. Designed to fit perfectly in the ErgoWorx® Microfiber Discharge Bucket. Available in white.

ERGOWORX® STARTER KITS

We offer two Starter Kits. SYSK-1 includes the following: (1 ea) SYS-5, MFT-5BK, C714000, (2) A80805, (10) C103020, (12) E810016). SYSK-2 includes the following: (1 ea) SYS-5, C714000, (2) A80805, (10) C103020, (12) E810016).

ERGOWORX® ACCESSORIES

A full line of products to use in conjunction with the ErgoWorx® System is shown on pages 24-27.

EARTHTONE™

DERMA-TEK®
FINISH



A80805 Laundry Net Bag

SYS-5 shown w/
MFT-5BK &
C714000 Handle



PATENTED



Universal swivel joint has cross-pin and ferrule nut connector for a secure and positive lock.

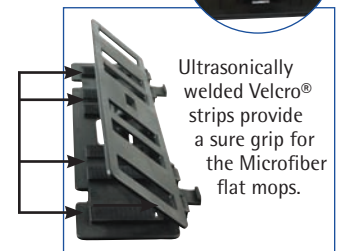

Ultrasonically welded Velcro® strips provide a sure grip for the Microfiber flat mops.

Brand	Item #	Description	Size	Case Pack	Case Weight	Case Cubic Ft.	Stock Item
Continental	SYS-5	CB-5YW, SB-5YW, MF-5BK, Yellow/Black	22" x 19 ⁷ / ₈ " x 11 ⁵ / ₈ "	1	10.24 lbs.	2.640	✓
Continental	MFT-5BK	ErgoWorx® Trolley for SYS-5, Black	31 ³ / ₄ " x 23" x 38 ¹ / ₂ "	1	13.80 lbs.	2.270	✓
Continental	CB-5YW	Solution Bucket w/Perf. Screen, Yellow/Black	22" x 12 ³ / ₈ " x 11 ⁵ / ₈ "	1	5.72 lbs.	1.910	✓
Continental	SB-5YW	Discharge Bucket w/Alum. Rod, Yellow	22" x 8" x 11 ¹ / ₈ "	1	3.54 lbs.	1.280	✓
Continental	MF-5BK	Auto Discharge Mop Frame, Black	18" x 5 ⁵ / ₈ " x 1 ³ / ₄ "	1	1.62 lbs.	0.160	✓
Continental	SYSK-1	Starter Kit w/Trolley	Multiple Items	1	29.14 lbs.	5.670	✓
Continental	SYSK-2	Starter Kit w/out Trolley	Multiple Items	1	15.34 lbs.	3.480	✓
Wilco	A80805	Laundry Net Bag, White	21" x 6 ³ / ₄ " x 9 ¹ / ₂ "	5	2.40 lbs.	0.626	✓

For the latest information on our products and their availability, go to www.continentalcommercialproducts.com



MICROFIBER MOPS

Mops made of microfiber offer many advantages to today's cleaning challenges. Wilen's line of microfiber mops are made with 100% microfiber of the highest quality, ultrafine synthetic fiber that is very durable, with superior bacteria removal.

WHAT IS MICROFIBER?

Unlike conventional mop yarns, each strand of microfiber is wedge-shaped with sharp edges which makes it very effective for removing, absorbing and accumulating virtually any type of dirt, dust, grease or contaminant. When paired with ErgoWorx® Touchless Cleaning System (See page 23), our system is an important component for a comprehensive Green Cleaning Program as per the US Green Building Council's (USGBC) LEED for Existing Buildings Rating System (LEED-ED:OM), Practice Greenhealth's Green Guide for Health Care and the Healthy Schools Campaign's Quick & Easy Guide to Green Cleaning in Schools.

- **More Cost Effective**
Lasts up to 6 times longer than traditional mops and cleans faster.
- **Healthier**
Superior bacteria removal; improves Hospital Consumer Assessment of Healthcare Providers and Systems (HCAHP) scores and reduces hospital acquired infections. Reduces bacteria on 95% of all hard surfaces.
- **Greener**
Significantly reduce consumption of water and chemicals; Re-usable and can be washed up to 500 times when cared for properly.
- **Safer**
Light weight mops reduce work strain.

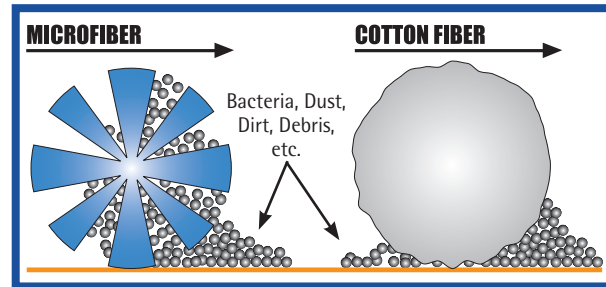

LAUNDERABLE REFILLS

[A] THE AGGRESSOR™ **EARTHTONE™**
This innovative combination of Microfiber yarn and synthetic stiff brush fibers is designed to remove debris stuck to the floor that normal "yarn only" Microfiber flat mops cannot.



[B] SUPER PRO™ FINISH FLAT MOP **EARTHTONE™**
The Microfiber Finish Flat Mop is looped-end and constructed of high-wet modulus rayon blend yarn that provides quick, controlled liquid release. The Finish Flat Mop will cover a 20" wide swath. Unlike conventional finish mops, 100% of the floor finish goes onto the floor along with full contact of the refill to the surface allowing better productivity and less chemical wasted in the mop. Should be rinsed after every use.



Brand	Item #	Description	Color	Size	Case Pack	Case Cubic Ft.	Case Cubic Ft.	Stock Item
Wilen	C109018	The Aggressor™	White/Green	5" x 18"	12	3.50 lbs.	0.247	✓
Wilen	C109020	The Aggressor™	White/Blue	5" x 20"	10	2.13 lbs.	0.404	✓
Wilen	C106020	Super Pro™ Finish Flat Mop	Light Blue	5" x 20"	6	1.40 lbs.	0.276	✓

LAUNDERABLE REFILLS

[A] SUPER PRO II™  **EARTHTONE™**

Looped-end construction and durable Microfiber provide long product life. Made of 100% Microfiber, it can be laundered 500 times, when cared for properly. Surged border is extremely durable. Hook and loop attachment for easy installation and removal from frame. Can be used for damp or dry mopping.

Brand	Item #	Color	Size	Case Pack	Case Weight	Case Cu. Ft.	Stock Item
Wilco	C103013	Blue	5" x 13"	12	2.00 lbs.	0.180	✓
Wilco	C103018	Blue	5" x 18"	12	3.00 lbs.	0.247	✓
Wilco	C103020	Blue	5" x 20"	10	2.30 lbs.	0.277	✓
Wilco	C103024	Blue	5" x 24"	12	4.00 lbs.	0.328	✓
Wilco	C104013	Red	5" x 13"	12	2.00 lbs.	0.180	✓
Wilco	C104018	Red	5" x 18"	12	3.00 lbs.	0.247	✓
Wilco	C104020	Red	5" x 20"	10	2.30 lbs.	0.277	✓
Wilco	C104024	Red	5" x 24"	12	4.00 lbs.	0.328	✓
Wilco	C107013	Yellow	5" x 13"	12	2.00 lbs.	0.180	✓
Wilco	C107018	Yellow	5" x 18"	12	3.00 lbs.	0.247	✓
Wilco	C107020	Yellow	5" x 20"	10	2.30 lbs.	0.277	✓
Wilco	C107024	Yellow	5" x 24"	12	4.00 lbs.	0.328	✓
Wilco	C108013	Green	5" x 13"	12	2.00 lbs.	0.180	✓
Wilco	C108018	Green	5" x 18"	12	3.00 lbs.	0.247	✓
Wilco	C108020	Green	5" x 20"	10	2.30 lbs.	0.277	✓
Wilco	C108024	Green	5" x 24"	12	4.00 lbs.	0.328	✓



[B] SUPER PRO II™  **EARTHTONE™**
MICROFIBER w/SCRUB REFILLS

Cut-end construction designed to penetrate into cracks and crevices in the floor. Fibers allow maximum scrubbing action to the floor's surface. Scrubbing strips remove scuff marks. Microfiber yarn allows up to 500 washings. Hook and loop backing for easy attachment and removal from Velcro® strip frame. Can be used damp or wet.

Brand	Item #	Color	Size	Case Pack	Case Weight	Case Cu. Ft.	Stock Item
Wilco	C123018	Blue	5" x 18"	12	3.00 lbs.	0.247	✓
Wilco	C124018	Red	5" x 18"	12	3.00 lbs.	0.247	✓
Wilco	C127018	Yellow	5" x 18"	12	3.00 lbs.	0.247	✓
Wilco	C128018	Green	5" x 18"	12	3.00 lbs.	0.247	✓
Wilco	C123024	Blue	5" x 24"	12	4.00 lbs.	0.328	✓
Wilco	C128024	Green	5" x 24"	12	4.00 lbs.	0.328	✓



MICROFIBER WET MOPS

[A] SUPER SORB TUBE MOPS EARTHSTONE™

This looped-end, wet mop is environmentally friendly because it requires less chemicals than cotton/blend yarn mops. Microfiber material offers excellent absorbency, as well as superior scrubbing power. Mops can be laundered 500 times. Mop features a 5" wide headband to be used with jaw type handles.



Brand	Item #	Size	Color	Case Pack	Case Weight	Case Cubic Ft.	Stock Item
Wilco	A10001	11 oz. / Sm	Blue	12	9.00 lbs.	0.984	✓
Wilco	A10002	14 oz. / Med	Blue	12	11.50 lbs.	1.813	✓
Wilco	A10003	18 oz. / Lg	Blue	12	14.50 lbs.	1.799	✓
Wilco	A10101	11 oz. / Sm	Green	12	9.00 lbs.	0.984	✓
Wilco	A10102	14 oz. / Med	Green	12	11.50 lbs.	1.813	✓
Wilco	A10103	18 oz. / Lg	Green	12	14.50 lbs.	1.799	✓

[B] DURALOOP WET MOP EARTHSTONE™

This mop will pick up twice as much liquid as a standard blended, looped-end mop. Can be used as a wax application mop. Use with Jaws type wet mop handles. Launder up to 150 times.



Brand	Item #	Size	Color	Case Pack	Case Weight	Case Cubic Ft.	Stock Item
Wilco	A09002	Medium	Blue	12	11.00 lbs.	0.970	✓
Wilco	A09003	Large	Blue	12	16.00 lbs.	1.260	✓



MICROFIBER MOP FRAMES & HANDLES

Our microfiber handles and frames are ideal for use in health-care facilities and schools. These professional grade products increase performance and maximize worker productivity. Durable and lightweight aluminum components provide long lasting quality and will not rust or corrode.

MICROFIBER HANDLES

[C] MICROFIBER PRO™ FLAT MOP HANDLES EARTHSTONE™

These handles are made of lightweight, long-lasting aluminum that will not rust or corrode. Twist-lock mechanism allows extendable handle to adjust from 33.5" to 60". Available in extendable and 60" fixed sizes.

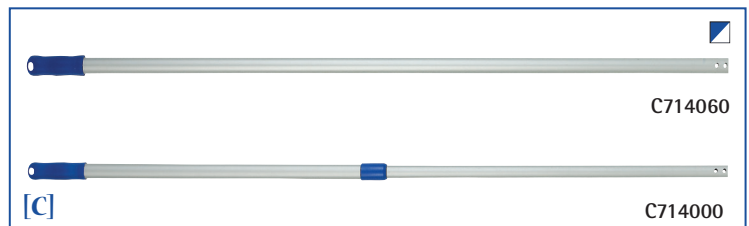

Brand	Item #	Size	Color	Case Pack	Case Weight	Case Cubic Ft.	Stock Item
Wilco	C714060	7/8" x 60" Fixed	Blue/Silver	10	6.50 lbs.	0.631	✓
Wilco	C714000	7/8" x 33 1/2" - 60"	Blue/Silver	10	5.00 lbs.	0.439	✓

MICROFIBER HANDLES

[A] ERGOFLO™ MOP HANDLE EARTHONE™

Lightweight, aluminum handle with 28 ounce solution reservoir. Trigger operated system allows quick and easy solution application for increased performance. Use with Pro II™ Microfiber Flat Mop Frames (page 27) or ErgoWorx® Frame (page 23). Covers up to 3,000 square feet.

[B] ERGOFLO™ KIT EARTHONE™

Our ErgoFlo™ Mop Handle is also available in a kit which includes a C717016 Pro II™ Flat Mop Frame and two C103018 18" Super Pro II™ blue mops.

Brand	Item #	Size	Color	Case Pack	Case Weight	Case Cu. Ft.	Stock Item
Continental	MFH-28	7/8" x 54 1/4"	Blue/Silver	1	1.40 lbs.	0.620	✓
Continental	SYSH-5	- - -	Blue/Silver	1	3.00 lbs.	0.320	✓

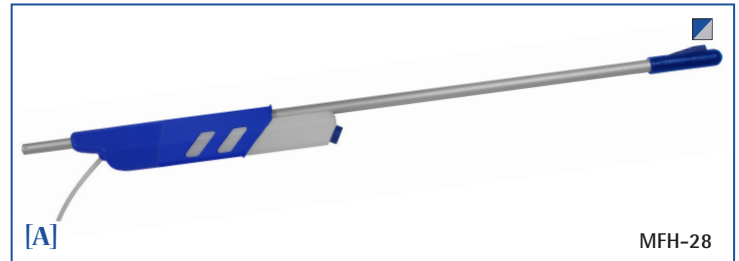

MICROFIBER FRAMES

[C] PRO II™ FLAT MOP FRAME EARTHONE™

Pro II™ Flat Mop Frame has a lightweight design that provides dramatic improvements in labor productivity. The trapezoid head effectively cleans corners and edges. 360° swivel attachment for maneuvering in tight areas. Handle Locking Clip secures handle to frame connector. Designed to compliment our line of Microfiber refills.

Brand	Item #	Size	Color	Case Pack	Case Weight	Case Cubic Ft.	Stock Item
Wilen	C717011	3" x 11"	Blue/Silver	10	4.00 lbs.	0.553	✓
Wilen	C717016	3" x 16"	Blue/Silver	10	6.00 lbs.	0.796	✓
Wilen	C717018	4 3/4" x 18"	Blue/Silver	10	7.00 lbs.	0.893	✓
Wilen	C717022	3" x 22"	Blue/Silver	10	9.00 lbs.	1.088	✓

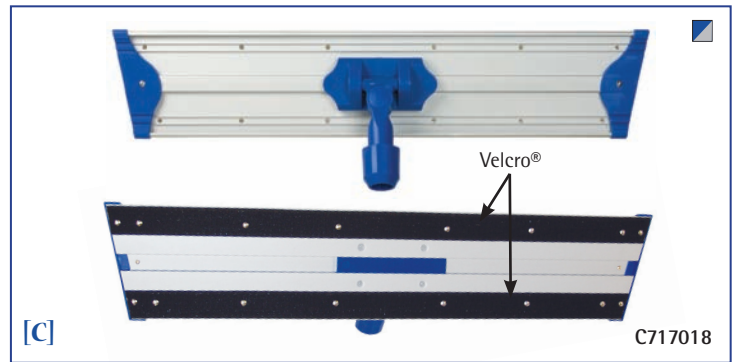

[D] SPRINGBACK™ MOP FRAME EARTHONE™

This heavy-duty aluminum frame, with its spring-loaded attachment, will hold up to three Charger™ disposable sheets. Removable 1/4" thick foam pad allows easy maneuvering while dry dust mopping. Can be used with our current Pro™ flat mop handles.

Brand	Item #	Size	Color	Case Pack	Case Weight	Case Cubic Ft.	Stock Item
Wilen	C716024	3 1/2" x 24"	Silver	10	13.00 lbs.	1.038	✓

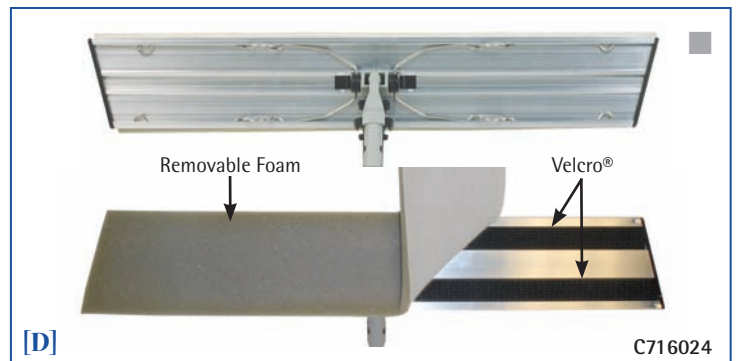

[E] 3-PIECE MICROFIBER HANDLE AND STIRRUP HEAD ADAPTOR EARTHONE™

Our new 3-piece handle allows for low cost shipping and assembles easily into a sturdy, long-lasting handle for flat mop frames. The new Stirrup Head Adaptor allows you to use a Microfiber Tube Mop or any traditional wet mop with a flat mop handle.

Brand	Item #	Size	Color	Case Pack	Case Weight	Case Cubic Ft.	Stock Item
Wilen	C714003	57"	Grey	12	10.70 lbs.	0.610	✓
Wilen	A70400	6 1/4"	Blue	12	3.00 lbs.	0.450	✓

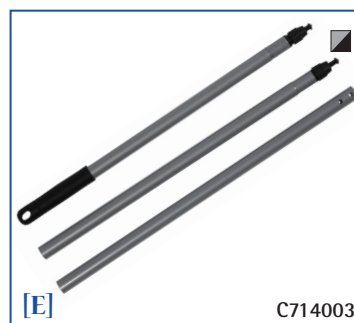



FLOOR SQUEEGEES

Our floor squeegees work in a variety of applications, whether you are removing water and debris from grouted tile or cleaning large smooth surfaces. Available in models for tapered handles or standard acme threaded handles.

[A] METAL FLOOR SQUEEGEES

Heavy zinc plated metal frames with a high grade dual edge and replaceable rubber blades. Designed for tapered handles. Straight squeegees feature a steel scraper edge.

Brand	Item #	Shape	Size	Case Pack	Case Weight	Case Cubic Ft.	Stock Item
Continental	1800	Straight	18"	2	4.00 lbs.	0.280	✓
Continental	2400	Straight	24"	2	5.00 lbs.	0.300	✓
Continental	3600	Straight	36"	2	6.38 lbs.	0.460	✓
Continental	C2400	Curved	24"	2	5.50 lbs.	0.480	✓
Continental	C3600	Curved	36"	2	7.12 lbs.	0.720	✓



Accepts tapered handles.
Found on page 51



[B] PLASTIC FLOOR SQUEEGEES

High-impact plastic frame is shock, rust and acid resistant. Dual soft foam rubber blades contour to fit to floor surfaces for greater liquid removal. Universal handle socket fits handles up to a 1" diameter.

Brand	Item #	Shape	Size	Case Pack	Case Weight	Case Cubic Ft.	Stock Item
Continental	1722	Straight	22"	6	4.62 lbs.	0.940	✓
Continental	1730	Straight	30"	6	5.94 lbs.	1.280	✓



Accepts threaded handles - up to 1" diameter.
Found on page 51



FLOOR SIGNS

Continental's complete line of safety signs and floor cones provide economical protection against slip and fall injuries and liabilities. Multilingual messages and universal symbols allow you to reach any audience.



FLOOR CONES

[A] QUAD-CONE

Available in 26" or 35" high with universal caution symbol on all four sides. Accommodates lock-on warning signs (S222-1RD), a ring weight (W222BK fits 222YW only), barrier chain (C123-2YW) and common barrier tape for cordoning off an area.

Brand	Item #	Height	Color	Case Pack	Case Weight	Case Cubic Ft.	Stock Item
Continental	221YW	26"	Yellow	3	9.25 lbs.	2.491	✓
Continental	222YW	35"	Yellow	3	14.53 lbs.	4.430	✓



[B] QUAD-CONE SYSTEM

This all-inclusive system contains three 35" yellow Quad-Cones, one 2" x 20' yellow Barrier Chain and two red Lock-On Warning Signs, to create an entire floor safety system.

Brand	Item #	Height	Color	Case Pack	Case Weight	Case Cubic Ft.	Stock Item
Continental	222-3YW	35"	Yellow	1	20.19 lbs.	4.430	✓



[C] LOCK-ON WARNING SIGN

Large square sign with imprint. Twist-locks onto 221YW or 222YW Quad-Cones. Case includes one each of both signs.

Brand	Item #	Height	Color	Case Pack	Case Weight	Case Cubic Ft.	Stock Item
Continental	S222-1RD	Adds 10 ³ / ₈ "	Red	2	2.42 lbs.	0.254	✓

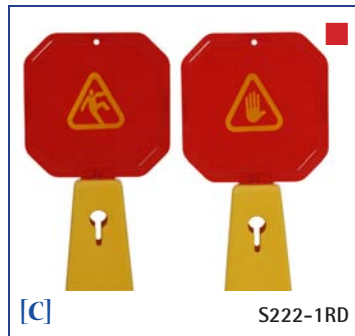

[D] BARRIER CHAIN

Plastic Barrier Chain easily locks into the Quad-Cone's exclusive keyhole design accessory port. Also fits 114, 119 and 120 easel-type floor signs.

Brand	Item #	Height	Color	Case Pack	Case Weight	Case Cubic Ft.	Stock Item
Continental	C123-2YW	2" x 20"	Yellow	3	3.24 lbs.	0.410	✓



FLOOR CONES

[A] RING WEIGHT

This 9 lb. black painted steel ring fits the 222YW Quad-Cone to prevent tipping in heavy winds.

Brand	Item #	Color	Case Pack	Case Weight	Case Cubic Ft.	Stock Item
Continental	W222-2BK	Black	3	9.25 lbs.	2.491	✓



[B] "WET FLOOR" CAUTION CONES

These orange, 18" high bilingual English/Spanish cones are made of vinyl plastic with a weighted tip-proof base.

Brand	Item #	Item	Color	Case Pack	Case Weight	Case Cubic Ft.	Stock Item
Continental	125ENG	English only	Orange	6	23.25 lbs.	1.930	✓
Continental	125SP	English & Spanish	Orange	6	23.25 lbs.	1.930	✓



[C] COLLAPSIBLE "CAUTION" TRI- CONES

These collapsible cones allow 360 degrees of visibility at a moment's notice. Both sizes come with storage tubes that can easily be mounted to a wall, janitor's cart or column. Universal symbol and trilingual message ensure easy readability.

Brand	Item #	Item	Color	Case Pack	Case Weight	Case Cubic Ft.	Stock Item
Continental	220-12	20" Cone	Yellow	12	11.40 lbs.	1.040	✓
Continental	230-12	30" Cone	Yellow	12	13.70 lbs.	1.570	✓



FLOOR SIGNS

[D] WET FLOOR SIGNS

26" high, easel-type signs with a two-sided trilingual (Eng/Sp/Fr) imprint message. Accepts Barrier Chain and common barrier tape for connecting multiple signs and cordoning off an area.

Brand	Item #	Item	Color	Case Pack	Case Weight	Case Cubic Ft.	Stock Item
Continental	119	"Caution" Sign	Yellow	6	16.95 lbs.	1.120	✓
Continental	119C	"Closed" Sign	Yellow	6	16.95 lbs.	1.120	✓



[E] MAXI-WARN™ WET FLOOR SIGNS

The new 37" high, easel-type floor sign with two-sided, trilingual (Eng/Sp/Fr) message. Accepts Barrier Chain and common barrier tape for connecting multiple signs and cordoning off an area.

Brand	Item #	Item	Color	Case Pack	Case Weight	Case Cubic Ft.	Stock Item
Continental	120	"Caution" Sign	Yellow	6	20.88 lbs.	2.840	✓
Continental	120C	"Closed" Sign	Yellow	6	20.88 lbs.	2.840	✓



JANITOR CARTS

Continental's line of janitor carts offers versatile designs with multiple stocking options and accessories.

Our exclusive Derma-Tek™ Smooth Surface makes our carts the easiest in the industry to clean and keep clean! All-plastic construction will not rust, chip, crack, peel or fade ... the color is molded throughout the sturdy structure. The exclusive four-legged design is more stable under heavy loads and actually helps to contain the load when over-stuffing the center collection area. Non-marking, grey, 8" rear wheels and 3" front swivel casters provide maximum maneuverability with minimum effort and prevent floor scuffing. Large oversized wheels and casters provide an effortless ride with minimal noise; ideal for any type of cleaning environment.

[A] COMPACT CLEANING CART

This cart is both space efficient and versatile enough for nearly any job. Designed to accommodate common cleaning items and waste collection, this cart is ideal for use in confined areas with limited storage space. Zippered Vinyl Bag included.

[B] JANITORS' CART

This cart is the workhorse of the industry! Designed to accommodate and organize tools and supplies required by today's stringent facility managers. Over-sized wheels and casters make this cart the logical choice for heavy-duty applications in health-care, airports, convention centers, theaters, shopping centers, office buildings and more! Zippered Vinyl Bag included.

Brand	Item #	Size	Color	Case Pack	Case Weight	Case Cubic Ft.	Stock Item
Continental	182GY	43 1/2" x 20 3/4" x 38"	Grey	1	31.00 lbs.	5.360	✓
Continental	182BL	43 1/2" x 20 3/4" x 38"	Blue	1	31.00 lbs.	5.360	✓
Continental	184GY	55 5/8" x 20 3/4" x 38"	Grey	1	38.00 lbs.	6.400	✓
Continental	184BL	55 5/8" x 20 3/4" x 38"	Blue	1	38.00 lbs.	6.400	✓



Optional Wall Hugger™ (23 gallon Receptacle) can be added as rigid plastic liner in place of the vinyl bag – without use of tools or additional hardware. Fits 184 and 186 Carts.

[A] CONVERTIBLE JANITOR CART

The only plastic cart in the industry that has a dual front tray to easily accommodate a combination of cleaning accessories including: 26 or 35 quart Splash Guard™ Mopping Combos, the Unibody® Mopping System, the 32 or 44 gallon Huskee™ and 44 gallon Huskee™ SuperKan™ (with or without the dolly). Zippered Vinyl Bag included.

[B] & [C] ACCESSORIES

Optional locking compartment (187YW) with dual wall construction provides a high level of security where needed. The CCP 184 and 186 Carts will accept two optional locking compartments.

Ergonomic bag (188YW) zips open completely to easily remove heavy contents and avoid back injury. 25 gallon capacity. Fits 182, 184 and 186 Carts.

[D] PORT-A-CART

Structural plastic shelves and a steel frame make this cart durable and economical. Features 3" swivel casters and a four bushel, yellow duck bag. (Shown with a 266-36 combo - not included).

[E] REPLACEMENT DUCK BAG

Heavy-duty replacement bags for our #271 Port-A-Cart. Packed six per case.



Brand	Item #	Size	Color	Case Pack	Case Weight	Case Cubic Ft.	Stock Item
Continental	186GY	73 ⁷ / ₈ " x 20 ³ / ₄ " x 38"	Grey	1	43.00 lbs.	6.770	✓
Continental	186BL	73 ⁷ / ₈ " x 20 ³ / ₄ " x 38"	Blue	1	43.00 lbs.	6.770	✓
Continental	187YW	---	Yellow	1	6.00 lbs.	0.620	✓
Continental	188YW	---	Yellow	6	8.06 lbs.	0.490	✓
Continental	271	39 ¹ / ₂ " x 18" x 34"	Blue	1	24.63 lbs.	3.290	✓
Continental	29	37 gal. (4 bushel)	Yellow	6	5.46 lbs.	0.760	✓

DUST MOPS

Choose any of our Wilen® dust mops to protect your floor and finish from abrasive dust and dirt. Use our application guide to help select the right dust mop for your needs.



Use our Application Guide (below), to help select the right mop for your needs.

DUST MOP APPLICATION GUIDE

Mop Type	Launderable				Disposable				Specialty			
	Permatwist™	Perma-Loop™	Swivel Snap™	Value Line™	Tie-Free®	Jean Clean®	E-Line Tie-Free® Untreated	E-Line Tie-Free® Treated	Durastat™	Microlooped™	Triangle	Roll-Out™
Fiber	Cotton/Poly	Recycled Cotton	Recycled Cotton	Recycled Cotton	Cotton/Synthetic	Recycled Denim	Cotton/Synthetic	Cotton/Synthetic	Synthetic	Microfiber	Cotton/Synthetic	Cotton/Synthetic
Construction	Cut-End	Looped-end	Cut-End	Cut-End	Cut-End	Cut-End	Cut-End	Cut-End	Cut-End	Looped-end	Cut-End	Cut-End
Backing	Key Hole	Key Hole	Key Hole	Open Back	Tie Free	Tie Free	Tie Free	Tie Free	Key Hole	Velcro®/Canvas	N/A	Tie-Free®, Stick M™
Pre-Treated	NO	NO	NO	NO	YES	NO	NO	YES	NO	NO	NO	NO
Size	5" x 18", 24", 36" 48", 60"	5" x 18", 24", 36" 48", 60"	5" x 18", 24", 36" 48", 60"	5" x 18", 24", 36" 48", 60"	5" x 18", 24", 36" 48", 60"	5" x 18", 24", 36" 48", 60"	5" x 18", 24", 36" 48", 60"	5" x 18", 24", 36" 48", 60"	5" x 18", 24", 36" 48", 60"	5" x 18", 24", 36" 48"	N/A	40'
Launderable	YES	YES	YES	YES	NO	NO	NO	NO	YES	YES	YES	NO
Durability	5	4	3	2	2	2	2	1	5		2	2
Dust/Dirt Retention	4	4	4	2	2	1	1	2	4		2	2
Linting	3	4	3	3	2	2	2	2	5		3	3
Healthcare	X	X							X	X		
Education			X	X	X	X	X	X			X	X
Industrial			X	X	X	X	X	X		X		
Property Mgmt.			X	X	X	X	X	X		X	X	
Lodging			X	X	X	X	X	X		X		

On the chart, above, 5 represents the highest quality.

Wilens® offers the Best Value in Dust Mops

The removal of dust and dirt particles is the first step in proper floor care. A preventative maintenance program using quality dust mops will protect your floor and finish from abrasive dust and dirt particles. To accommodate your needs, we offer a wider variety of dust mops to assist in the efficient removal of dust and dirt. Let the following information assist you in choosing which dust mop is right for your needs.

Yarn

Cotton is the most economical and popular yarn, despite its disadvantages when compared to other fibers. Cotton is often blended with synthetic fibers to add strength and absorbency. Some of these yarns are designed to withstand laundering while others, like disposables, are constructed with bulky, loosely twisted yarn for better dust removal. Our PermaTwist™ cotton yarn combines exceptional durability via a unique fiber bonding process. Nylon, like that used in our Durastat™, has electrostatic properties that attract dust particles without the use of treatment.

Backing

Synthetic backing material has replaced cotton as the industry standard because it dries much faster and absorbs less treatment than cotton. We also offer a variety of backing styles including: Open Back, Key Hole, Slot Pocket and Break-Away (illustrated at right). All four backing styles are available for construction in our Professional Dust Mop category. Ties are also available upon request. Our Swivel Snap category is available with a Key Hole style backing. Our Value Line category is available with an Open Back style. Our Disposable Dust Mops are available with backings as shown. Backing colors include: red, blue, green and white.

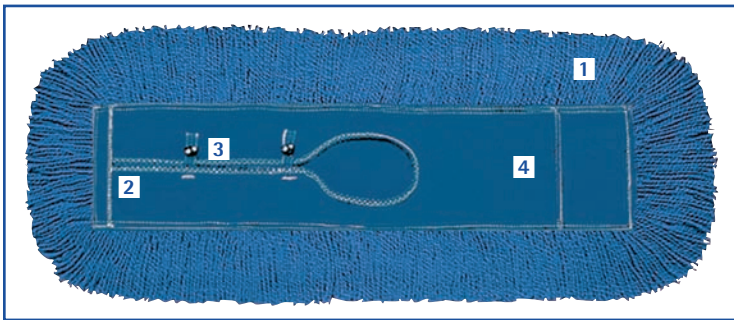
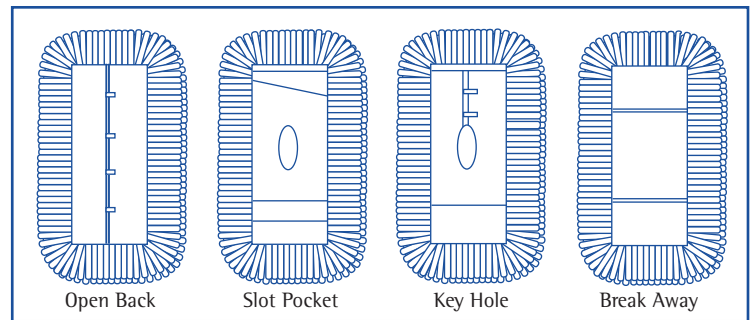

- 1 A wide variety of high grade yarns provide maximum durability and performance.
- 2 Extra stitching assures long life, even with laundering.
- 3 Heavy-duty, rust resistant snaps are fast and easy to use.
- 4 Durable synthetic (polyester) backing dries fast and is available in bright colors.

Cut-End

The cut-end dust mop, though more economical at first, tends to fray, unravel and lint. This can decrease its performance and lead to replacement of the mop. Laundering can decrease durability. Our PermaTwist™ solves this problem by bonding the yarn fibers.

Looped-End

By trapping more dust, producing less yarn debris and resisting tangles, the looped-end dust mop delivers maximum performance. Because looped-end yarns withstand heavy use and frequent laundering without fraying and unraveling, linting is virtually eliminated. Looped-end yarn is available in long strands for greater coverage or short loops for hi-tech and health care applications.



Durability

High quality construction standards lead to the best value in a dust mop. Wilens® mops are made with the highest level of professional quality with pre-shrunk backings and top grade yarn to withstand heavy use and repeated launderings. Reinforced stitching at stress points are signs of better mop construction. Innovative yarns, like our Twister Loop™, Durastat™ and PermaTwist™, can provide longer lasting service as well as increased performance.

Frames & Handles

To provide free swiveling or rigid handle positions, use a handle with a swivel-snap device attached to the frame. Frames are available from 12" to 72". Our Stick-M™ line uses a flat plastic base for maximum surface contact. Its Velcro® type attachment system allows quick and easy changes. Our Wear Ever™ Frame also provides a wide, flat surface for maximum yarn-to-floor contact, resulting in greater dust mop efficiency.

PROFESSIONAL DUST MOPS

DURABLE, LAUNDERABLE MOPS

These high performance dust mops are designed and constructed for industrial launderers, health care facilities and other demanding applications. Innovative yarns, pre-shrunk synthetic backings and heavy-duty construction techniques provide maximum durability and efficiency.

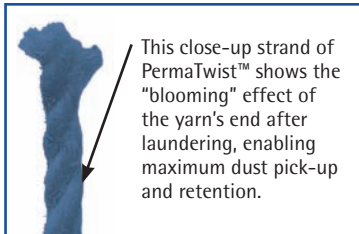

[A] PERMATWIST™ EARTHTONE™

Exclusive bonding process of 100% ring-spun cotton yarn virtually eliminates fraying and linting. Brilliant, permanent colors keep this duster looking new. PermaTwist™ delivers unsurpassed durability and performance and is the best dust mop you can buy. Launderable.

Brand	Item #	Color	Stock Item	Item #	Color	Stock Item	Item #	Color	Stock Item	Size	Case Pack	Case Weight	Case Cu. Ft.
Wilco	C001018	Natural	✓	C003018	Blue	✓	C004018	Green	✓	18"	12	12.00 lbs.	1.290
Wilco	C001024	Natural	✓	C003024	Blue	✓	C004024	Green	✓	24"	12	15.00 lbs.	1.812
Wilco	C001036	Natural	✓	C003036	Blue	✓	C004036	Green	✓	36"	12	22.00 lbs.	2.265
Wilco	C001048	Natural	✓	C003048	Blue	✓	C004048	Green	✓	48"	6	15.00 lbs.	1.812
Wilco	C001060	Natural	✓	C003060	Blue	✓	C004060	Green	✓	60"	6	18.00 lbs.	1.812



[B] TWISTER LOOP™ EARTHTONE™

Twisted loop cotton yarn provides maximum durability for laundering and heavy use. No cut ends to lint and fray. Twisted yarn provides an effective dust trap for better collection and retention. Yarn is dyed and laundered.

Brand	Item #	Color	Stock Item	Item #	Color	Stock Item	Item #	Color	Stock Item	Item #	Color	Stock Item	Size	Case Pack	Case Weight	Case Cu. Ft.
Wilco	C013018	Natural		C014018	Red		C015018	Blue	✓	C016018	Green		18"	12	12.00 lbs.	1.290
Wilco	C013024	Natural		C014024	Red		C015024	Blue	✓	C016024	Green		24"	12	15.00 lbs.	1.812
Wilco	C013036	Natural		C014036	Red		C015036	Blue	✓	C016036	Green		36"	12	22.00 lbs.	2.265
Wilco	C013048	Natural		C014048	Red		C015048	Blue	✓	C016048	Green		48"	6	15.00 lbs.	1.812
Wilco	C013060	Natural		C014060	Red		C015060	Blue	✓	C016060	Green		60"	6	18.00 lbs.	1.812

Lead times for dust mops vary. Typically, all non-stock items can be shipped within four weeks.

PROFESSIONAL DUST MOPS

[A] PERMA-LOOP™ EARTHTONE™

High-grade, cotton blend looped-end yarn won't fray or unravel even with intensive laundering, ensuring longer life than conventional cut-end yarn. Long loops are for maximum dust collection. 5" wide backing.



[A]

C041024

Brand	Item #	Color	Stock Item	Item #	Color	Stock Item	Size	Case Pack	Case Weight	Case Cubic Ft.
Wilco	C041018	Natural	✓	C042018	Blue	✓	18"	12	12.00 lbs.	1.290
Wilco	C041024	Natural	✓	C042024	Blue	✓	24"	12	15.00 lbs.	1.812
Wilco	C041036	Natural	✓	C042036	Blue	✓	36"	12	22.00 lbs.	2.265
Wilco	C041048	Natural	✓	C042048	Blue	✓	48"	12	30.00 lbs.	2.265
Wilco	C041060	Natural	✓	C042060	Blue	✓	60"	6	18.00 lbs.	1.812

[B] DURASTAT™ EARTHTONE™

Durable 2-ply synthetic yarn attracts dust like a magnet using electro-static properties. Unlike other mops, Durastat™ requires no treatment, making it ideal for use in chemical sensitive areas like hospitals and laboratories. In addition, the extra durable yarn is virtually lintless and frayless even with intensive laundering.



[B]

C052024

Brand	Item #	Color	Stock Item	Item #	Color	Stock Item	Size	Case Pack	Case Weight	Case Cubic Ft.
Wilco	C051018	White	✓	C052018	Blue	✓	18"	12	8.00 lbs.	1.290
Wilco	C051024	White	✓	C052024	Blue	✓	24"	12	10.00 lbs.	1.812
Wilco	C051036	White	✓	C052036	Blue	✓	36"	12	15.00 lbs.	2.265
Wilco	C051048	White	✓	C052048	Blue	✓	48"	12	19.00 lbs.	2.828
Wilco	C051060	White	✓	C052060	Blue	✓	60"	6	11.00 lbs.	1.812

CONVENTIONAL DUST MOPS

[C] SWIVEL SNAP™ EARTHTONE™

This industry standard dust mop is constructed of 4-ply cotton blended yarn sewn to a durable polyester backing. Absorbent yarn provides excellent dust retention.



[C]

C057048

Brand	Item #	Color	Stock Item	Item #	Color	Stock Item	Size	Case Pack	Case Weight	Case Cubic Ft.
Wilco	C057018	Natural	✓	C058018	Blue	✓	18"	12	12.00 lbs.	1.290
Wilco	C057024	Natural	✓	C058024	Blue	✓	24"	12	15.00 lbs.	1.290
Wilco	C057036	Natural	✓	C058036	Blue	✓	36"	12	22.00 lbs.	1.812
Wilco	C057048	Natural	✓	C058048	Blue	✓	48"	12	30.00 lbs.	2.270
Wilco	C057060	Natural	✓	C058060	Blue	✓	60"	6	18.00 lbs.	1.812

CONVENTIONAL DUST MOPS

[A] VALUE LINE™  **EARTH-TONE™**

This economical, yet durable dust mop is constructed with 4-ply, long staple cotton yarn which is tufted into white polyester backing, providing more yarn for better dust collection. Open back style with ties. Natural yarn only.

Brand	Item #	Size	Color	Case Pack	Case Weight	Case Cubic Ft.	Stock Item
Wilco	C302018	18"	Natural	12	11.00 lbs.	1.290	✓
Wilco	C302024	24"	Natural	12	14.00 lbs.	1.290	✓
Wilco	C302036	36"	Natural	12	21.00 lbs.	1.812	✓
Wilco	C302048	48"	Natural	12	26.00 lbs.	2.828	✓
Wilco	C302060	60"	Natural	6	18.00 lbs.	1.812	✓

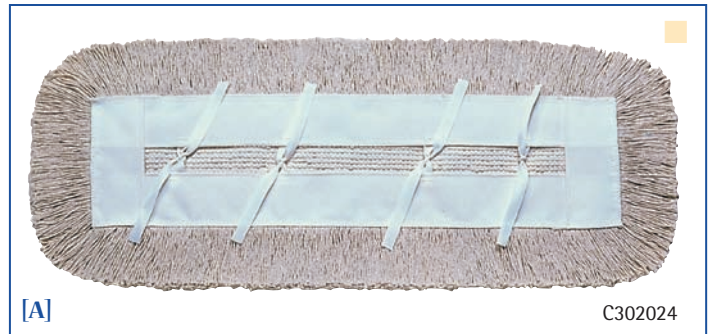

DISPOSABLE DUST MOPS

[B] E-LINE TIE-FREE® DISPOSABLE  **EARTH-TONE™**

4-ply Cotton/Synthetic yarn with polyester backing for performance, durability and value. Split center provides a trap to collect dust and dirt. Available pre-treated with Dust n' Shine™ or untreated. Use with Swivel Snap™ frame and handle.

Brand	Item #	Backing	Size	Color	Case Pack	Case Weight	Case Cubic Ft.	Stock Item
Wilco	C404018	Untreated	18"	Natural	12	10.00 lbs.	1.290	✓
Wilco	C404024	Untreated	24"	Natural	12	13.00 lbs.	1.812	✓
Wilco	C404036	Untreated	36"	Natural	12	17.00 lbs.	2.265	✓
Wilco	C404048	Untreated	48"	Natural	12	21.00 lbs.	2.828	✓
Wilco	C404060	Untreated	60"	Natural	6	12.00 lbs.	1.812	✓
Wilco	C414018	Treated	18"	Natural	12	10.00 lbs.	1.290	✓
Wilco	C414024	Treated	24"	Natural	12	13.00 lbs.	1.812	✓
Wilco	C414036	Treated	36"	Natural	12	17.00 lbs.	2.265	✓
Wilco	C414048	Treated	48"	Natural	12	21.00 lbs.	2.828	✓
Wilco	C414060	Treated	60"	Natural	6	12.00 lbs.	1.812	✓



[C] TIE-FREE® DISPOSABLE  **EARTH-TONE™**

Cotton/synthetic yarn with Tie-Free™ backing provides performance, durability and value. Bulky, absorbent, pre-treated 4-ply yarn collects and retains more dust and will cover over a million square feet before replacement is needed. Split center provides a trap to collect even more dust.

Brand	Item #	Size	Color	Case Pack	Case Weight	Case Cubic Ft.	Stock Item
Wilco	C401018	18"	Natural	12	10.00 lbs.	1.290	✓
Wilco	C401024	24"	Natural	12	13.00 lbs.	1.812	✓
Wilco	C401036	36"	Natural	12	17.00 lbs.	2.265	✓
Wilco	C401048	48"	Natural	12	21.00 lbs.	2.828	✓
Wilco	C401060	60"	Natural	6	12.00 lbs.	1.812	✓



DISPOSABLE DUST MOPS

[A] JEAN CLEAN® DISPOSABLE EARTHTONE™

Yarn is constructed of reconditioned denim and other textile materials, making it more durable and absorbent than standard cotton blended yarn. Cotton/polyester 4-ply yarn prevents fraying and tough Tie-Free™ backing provides performance and durability. Colored yarn hides dirt.

Brand	Item #	Size	Color	Case Pack	Case Weight	Case Cubic Ft.	Stock Item
Wilco	C412018	18"	Blue	12	10.00 lbs.	1.290	
Wilco	C412024	24"	Blue	12	13.00 lbs.	1.812	✓
Wilco	C412036	36"	Blue	12	17.00 lbs.	1.812	✓
Wilco	C412048	48"	Blue	12	21.00 lbs.	2.265	
Wilco	C412060	60"	Blue	6	12.00 lbs.	1.812	



ROLL-OUT™ DUST CONTROL

[B] ROLL-OUT™ DISPOSABLE

40 foot roll of disposable dust mop. Pre-treated, open twist, blended cotton/synthetic yarn is sewn to a Tie-Free backing. Knife included for cutting to size to fit holder. Available in Stick-M™ and Tie-Free™ backing styles.

Brand	Item #	Type	Size	Color	Case Pack	Case Weight	Case Cubic Ft.	Stock Item
Wilco	C601000	Stick-M™	40'	Natural	1	16.00 lbs.	1.636	✓
Wilco	C630000	Tie-Free™	40'	Natural	1	16.00 lbs.	1.636	✓



TRIANGLE DUST MOPS

[C] TRIANGLE DUST MOP

This small duster lies flat for use in tight areas like offices and classrooms. Removable mop head is launderable and available with standard cotton blend yarn. 4" x 8.5" wire frame attached to 54" wood handle. Yarn spread measures 12" x 17". Optional Frame and Connector allows use of any standard threaded handle.

Brand	Item #	Item	Color	Case Pack	Case Weight	Case Cubic Ft.	Stock Item
Wilco	C501000	Mop Refills	Natural	12	6.00 lbs.	0.564	✓
Wilco	C903000	Frame/Handle	N/A	12	15.00 lbs.	2.620	✓
Wilco	C707000	Frame/Connector	N/A	12	7.00 lbs.	2.506	✓

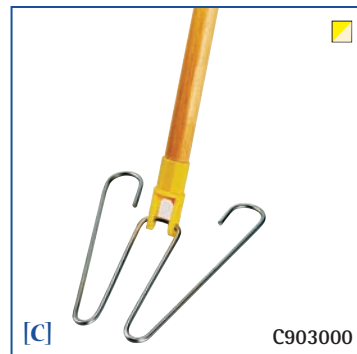



MICROFIBER DUST MOPS

Microfiber Dust Mops take dry mopping to a new level by adding the performance and durability of microfiber. Whether using traditional dust mopping equipment or Velcro® frames, microfiber dust mops offer superior dust collecting properties, attracting and holding dust electrostatically.

These mops are more efficient and last longer than typical cotton/blended dust mops. Available in both conventional keyhole style backing that accepts industry standard frames as well as hook and loop packing for Velcro® frames.

[A] MICROLOOPEDED MICROFIBER

VELCRO® & CANVAS
BACKED DUST MOPS



EARTHTONE™

Microfiber dust mops pick up dirt and dust electrostatically. These mops are more efficient and last longer than typical cotton/blended dust mops. Microfiber dust mops are available with both conventional keyhole style backing that accepts industry standard dust mop frames (18"/Yellow, 24"/Green, 36"/Red, 48"/Blue), as well as hook and loop backing for Velcro® frames.

Brand	Item #	Backing	Size	Color	Case Pack	Case Weight	Case Cubic Ft.	Stock Item
Wilco	C091018	Velcro®	18"	Blue/Grey	12	4.00 lbs.	1.039	✓
Wilco	C091024	Velcro®	24"	Blue/Grey	12	5.00 lbs.	1.039	✓
Wilco	C091036	Velcro®	36"	Blue/Grey	12	6.00 lbs.	1.039	✓
Wilco	C091048	Velcro®	48"	Blue/Grey	12	8.00 lbs.	1.365	✓
Wilco	C092018	Canvas	18"	Blue/Grey	12	5.50 lbs.	1.039	✓
Wilco	C092024	Canvas	24"	Blue/Grey	12	6.50 lbs.	1.039	✓
Wilco	C092036	Canvas	36"	Blue/Grey	12	9.00 lbs.	1.039	✓
Wilco	C092048	Canvas	48"	Blue/Grey	12	11.50 lbs.	1.861	✓
Wilco	C092060	Canvas	60"	Blue/Grey	12	13.00 lbs.	1.861	✓



[B] VELCRO®

DUST MOP ADAPTOR



EARTHTONE™

Our new Velcro® Dust Mop Adaptors work with our Swivel Snap Frames, as well as other standard mop frames. Use these adaptors to transition from standard dust mops to high-performance Microfiber Dust Mops using the same frames and handles. Use with Microlooped Velcro® Dust Mops.

Brand	Item #	Size	Color	Case Pack	Case Weight	Case Cubic Ft.	Stock Item
Wilco	C095018	6 1/4" x 18"	Grey	12	2.51 lbs.	0.180	✓
Wilco	C095024	6 1/4" x 24"	Grey	12	2.60 lbs.	0.230	✓
Wilco	C095036	6 1/4" x 36"	Grey	12	2.70 lbs.	0.300	✓
Wilco	C095048	6 1/4" x 48"	Grey	12	2.90 lbs.	0.390	✓

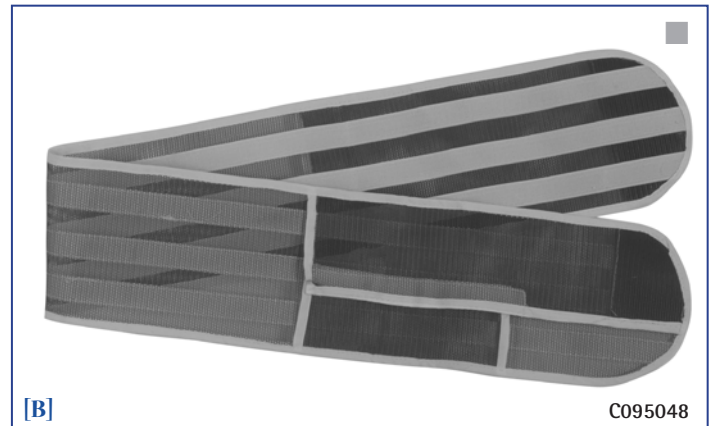

[A] MICROLOOPED DUST MOP



EARTHTONE™

This mop will pick up twice as much dirt as a 100% cotton cut-end dust mop. Can be used as a wax application mop. Fits any standard dust mop frame. Launder up to 150 times.

Brand	Item #	Backing	Size	Color	Case Pack	Case Weight	Case Cubic Ft.	Stock Item
Wilco	C090018	Canvas	18"	Blue	12	4.50 lbs.	0.810	✓
Wilco	C090024	Canvas	24"	Blue	12	6.00 lbs.	1.070	✓
Wilco	C090036	Canvas	36"	Blue	12	8.00 lbs.	1.600	✓
Wilco	C090048	Canvas	48"	Blue	6	5.50 lbs.	1.070	✓

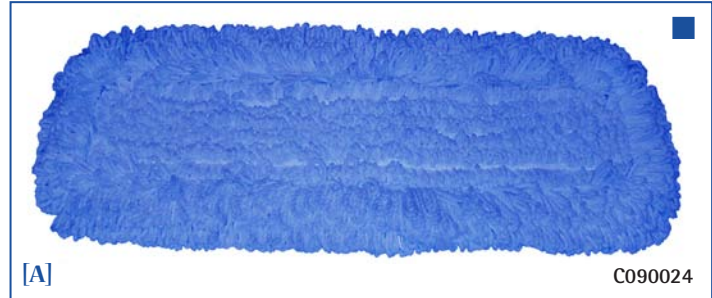

[B] THE DUSTER



EARTHTONE™

Specially designed to attract dust, much like a cut-end dust mop, but has the strength and durability of Microfiber. Use to pick up larger particles before damp mopping or disinfecting. Can be laundered up to 150 times. Use with ErgoWorx® Frame or Pro II™ Flat Mop Frame.

Brand	Item #	Size	Color	Case Pack	Case Weight	Case Cubic Ft.	Stock Item
Wilco	C110020	20"	White	10	2.30 lbs.	0.208	✓



[C] CHARGER™ DISPOSABLE DUST MOP



EARTHTONE™

The Charger™ Disposable Dust Mop picks up dust, dirt and hair by creating a static charge and trapping the debris within the mop's tiny fibers. Using this inexpensive, disposable dust mop aids in cross-contamination prevention for health care environments. The Charger™ mop comes conveniently packed in 200 pre-cut sheets per box, and attaches easily to the SpringBack™ mop frame. This mop is NOT microfiber, however, it is used with Springback™ Mop Frame, found on page 27.

Brand	Item #	Size	Color	Case Pack	Case Weight	Case Cubic Ft.	Stock Item
Wilco	C429000	8" x 26"	White	200	5.01 lbs.	1.523	✓





DUST MOP HANDLES & FRAMES

We feature dust mop handles with both free-swiveling and rigid handle positions. Our frames are available in sizes ranging from 18 to 72 inches. Mix and match with our wide variety of dust mops to suit your needs.

DUST MOP HANDLES

[A] SWIVEL SNAP™ HANDLES

The regular Swivel Snap™ handle features 180° swivel action or rigid position and spring clip. Shafts are available in wood and fiberglass.

Brand	Item #	Handle	Size	Case Pack	Case Weight	Case Cubic Ft.	Stock Item
Wilco	C801060	Wood	15/16" x 60"	12	25.00 lbs.	1.100	✓
Wilco	C801260	Fiberglass	1" x 60"	12	25.00 lbs.	1.100	✓



DUST MOP FRAMES

[B] SWIVEL SNAP™ FRAMES

These heavy-duty, industry standard frames are constructed of rust resistant black powder coated metal wire for long life. Swivel Snap™ frame features welded one-piece construction. Use with our Swivel Snap™ Handle.

Brand	Item #	Size	Color	Case Pack	Case Weight	Case Cubic Ft.	Stock Item
Wilco	C702018	5" x 18"	Black	12	8.00 lbs.	0.302	✓
Wilco	C702024	5" x 24"	Black	12	11.00 lbs.	0.452	✓
Wilco	C702036	5" x 36"	Black	12	14.00 lbs.	0.615	✓
Wilco	C702048	5" x 48"	Black	12	17.00 lbs.	0.849	✓
Wilco	C702060	5" x 60"	Black	12	20.00 lbs.	1.059	✓
Wilco	C702072	5" x 72"	Black	12	25.00 lbs.	1.269	✓

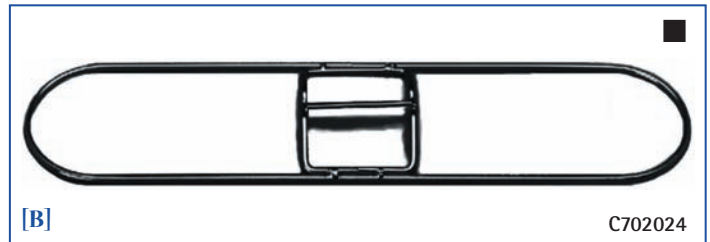

[C] VELCRO® DUST MOP ADAPTOR **EARTHTONE™**

Our new Velcro® Dust Mop Adaptors work with our Swivel Snap Frames, as well as other standard dust mop frames. Use these adaptors to transition from standard dust mops to high-performance Microfiber Dust Mops using the same frames and handles. Use with Microlooped Velcro® Dust Mops.

Brand	Item #	Size	Color	Case Pack	Case Weight	Case Cubic Ft.	Stock Item
Wilco	C095018	6 1/4" x 18"	Grey	12	2.51 lbs.	0.180	✓
Wilco	C095024	6 1/4" x 24"	Grey	12	2.60 lbs.	0.230	✓
Wilco	C095036	6 1/4" x 36"	Grey	12	2.70 lbs.	0.300	✓
Wilco	C095048	6 1/4" x 48"	Grey	12	2.90 lbs.	0.390	✓

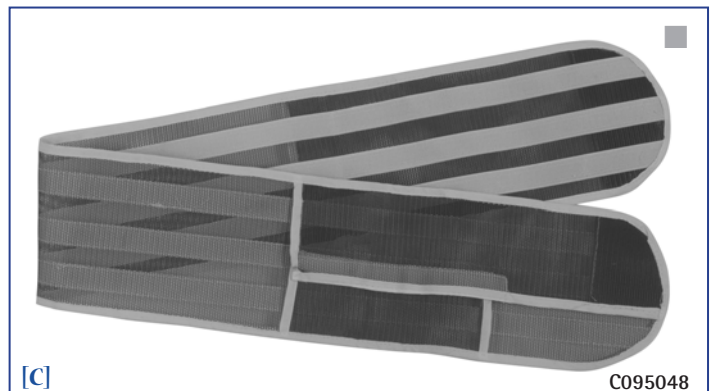

DUST MOP FRAMES

[A] WEAR-EVER™ PLASTIC FRAME



High-impact plastic frame won't rust or bend and lasts up to ten times longer than metal frames. Flat bottom allows better surface contact with dust mop, resulting in superior performance. Also eliminates the stress points common to wire frames that cause premature mop wear. Use with our Swivel Snap™ handle.

[B] STICK-M™ HOLDER



High-impact plastic frame features Velcro® on bottom for quick and easy attachment of refills. Flat bottom allows total surface contact with dust mop for superior dust collection. Uses Swivel Snap™ handles.



Brand	Item #	Size	Color	Case Pack	Case Weight	Case Cubic Ft.	Stock Item
Wilco	C703024	5" x 24"	Yellow	6	13.00 lbs.	1.030	✓
Wilco	C704024	5" x 24"	Yellow	6	13.00 lbs.	1.030	✓



FLOOR SWEEPERS

[C] HUSKEE™ SWEEPER



Our commercial sweeper with horsehair and boar brush agitation has a 180° handle. It has a low profile design and textured paint that resists scratches, while allowing unit to lay flat to go under furniture. Rubber bumpers prevent wall and door damage.

[D] HUSKEE™ POWERROTOR SWEEPER



These sweepers clean hard floors and carpets. The self-cleaning flexible rubber blades beat the floor with high frequency, creating friction and momentum that cleanly transports dirt, food, lint and other debris into the dust compartments. Durable plastic body resists scratches and dents and is easy on walls, doors and furniture.



FLOOR SWEEPERS

Huskee Floor Sweepers are the economic, environmentally friendly cleaning solution you've been looking for! Perfect for any type of cleaning environment, especially food service facilities and restaurants and busy hotel and hospital lobbies. Our sweepers are designed to be an easy to use, silent and effective answer to your everyday cleaning needs.



Brand	Item #	Width	Color	Case Pack	Case Weight	Case Cubic Ft.	Stock Item
Continental	5323	9 1/2"	Black/Blue	1	2.72 lbs.	0.500	✓
Continental	5325	9 1/2"	Black	1	2.51 lbs.	0.220	✓
Continental	5327	12 1/2"	Black	1	3.74 lbs.	0.360	✓



DUST PANS

Picking up dust and debris has never been easier with our complete assortment of dust pans. We have a wide range of sizes and styles to fit your specific needs. Perfect for industrial, commercial and outdoor use.

DUST PANS

[A] PLASTIC DUST PAN



Constructed of tough, yet flexible, black plastic with thin front edge for maximum dirt pick up. Handle hanger hole for easy hanging.

[B] UTILITY DUST PAN



Constructed of tough, yet flexible, black plastic with a contoured handle that snaps onto standard broom handles for easy storage and accessibility. Rubber lip lets you sweep up dust and dirt that most dust pans miss. Hang hole for wall storage.

[C] JUMBO DUST PAN



This lightweight, yet strong dust pan has an 18" mouth, making it ideal for outdoor maintenance such as picking up leaves and other debris that require a large capacity. Contoured handle has a hang hole and also fits on standard broom or rake handles for easy storage and accessibility. Rubber feet prevent sliding on smooth surfaces.

[D] HEAVY DUTY METAL DUST PAN



This dust pan ribbed for extra strength and powder coated for longer life. Angled front edge for maximum dirt pick up. Handle hanger hole for easy storage.

[E] EXTRA WIDE METAL DUST PAN



Heavy-duty 16" wide metal dust pan is ribbed for strength and powder coated for longer life. Angled front edge for maximum dirt pick up. Handle hanger hold for easy storage.

[F] LOBBY DUST PAN



Durable plastic hopper with vinyl coated steel handle. Pan snap-locks in use and releases to dump or carry. Space saving hanger for storage. The true-edge of pan conforms to floor - no need for repeated sweeping. Serrated yoke provides area to "comb" debris from lobby broom.

[G] METAL LOBBY DUST PAN



Self opening and closing lid with extra long chrome handle. Pan/door are metal with powder coated finish for longer life. Standard is #808 - also available with an "L" grip handle, #808L, for comfort and control.

[H] PICK UP DUST PAN



Metal dust pan with powder coated finish. Chrome handle with hanger.



[A]

712



[B]

E601000



[C]

E603000



[D]

715



[E]

716



[F]

912BK



[G]

808



[H]

825

Brand	Item #	Size	Color	Case Pack	Case Weight	Case Cu. Ft.	Stock Item
Continental	712	12 ¹ / ₄ " x 12"	Black	12	5.10 lbs.	1.370	✓
Wilco	E601000	15" x 11"	Black	12	11.00 lbs.	1.100	✓
Wilco	E603000	18 ³ / ₈ " x 18"	Black	12	5.00 lbs.	2.828	✓
Continental	715	13 ¹ / ₂ " x 12"	Black	2 dz.	29.88 lbs.	1.720	✓
Continental	716	15" x 16"	Black	12	26.88 lbs.	2.520	✓
Continental	912BK	10" x 12"	Black	6	9.60 lbs.	1.500	✓
Continental	808	9 ³ / ₄ " x 12"	Black	6	25.02 lbs.	3.240	✓
Continental	808L	9 ³ / ₄ " x 12"	Black	1	5.75 lbs.	1.980	✓
Continental	825	9" x 12"	Black	6	20.22 lbs.	3.300	✓



BROOMS

Our professional grade angle brooms and corn brooms are designed to provide efficient sweeping, reaching into corners, along base boards or into hard-to-reach areas for fast, effective cleaning. Available in sizes for all needs, from small stores to warehouses.

LOBBY BROOMS

[A] ANGLED LOBBY BROOM



Angled lobby broom with flagged polypropylene bristles, black plastic frame and 7/8" diameter wood handle. Bristle length is from 4 to 5 inches.

[B] SYNTHETIC LOBBY BROOM



At 35" high, this broom is perfectly sized for use with our lobby dustpan. Stiff, flagged, polypropylene bristles do an excellent job of collecting debris on floor surfaces ranging from carpet to tile.



Brand	Item #	Size	Bristle Type	Bristle Color	Bristle Trim	Size/Material of Handle	Case Pack	Case Weight	Case Cubic Ft.	Stock Item
Continental	E500000	8" x 35 1/2"	Flagged Polypropylene	Natural	4" - 5"	7/8" Wood	12	11.10 lbs.	2.310	✓
Wilco	E503600	8" x 35"	Flagged Polypropylene	Black	4"	7/8" Metal	6	4.00 lbs.	1.030	✓

CLEAN SWEEP™ BROOMS

Upgrade your corn broom line with Clean Sweep™, the highest quality corn brooms made. For routine or heavy-duty cleaning, these durable upright brooms are designed for long life and efficient sweeping. Most are available with your choice of 100% broom corn or economical blend fibers. All brooms feature double-stitched, nylon cord bound fibers that are wire wrapped onto wood handles.

[C] CORN/CORN BLEND BROOMS



The Clean Sweep™ Corn Broom line features high quality corn brooms made for routine or heavy duty cleaning. These durable upright brooms are designed for long life and efficient sweeping.



Brand	Item #	Description	Bristle	Fill Weight	Number of Stitches	Stitch Color	Metal Band	Size/Color of Handle	Total Length	Case Pack	Case Weight	Case Cubic Ft.	Stock Item
Wilco	E502036	Warehouse	Blend	32#	5	Black	Yes	1 1/8" Brown	56"	6	16.00 lbs.	3.263	✓
Wilco	E502028	Warehouse	Blend	28#	4	Black	Yes	1 1/8" Brown	56"	6	14.00 lbs.	4.296	✓
Wilco	E503028	Warehouse	100% Corn	28#	4	Red	Yes	1 1/8" Brown	56"	6	14.00 lbs.	3.888	✓
Wilco	E504028	Janitor	Blend	28#	5	Black	No	1 1/8" Black	55 1/2"	6	14.00 lbs.	1.489	✓
Wilco	E502024	Housekeeper	Blend	24#	4	Black	No	7/8" Brown	53 1/2"	6	12.00 lbs.	1.460	✓
Wilco	E502018	Fan Maid	Blend	18#	4	Black	No	7/8" Brown	54"	6	9.00 lbs.	1.583	✓
Wilco	E503017	Maid	100% Corn	17#	5	Red	No	7/8" Brown	52 1/2"	6	9.00 lbs.	1.583	✓
Wilco	E503500	Lobby	Blend	7#	3	Black	No	7/8" Brown	38 1/2"	12	9.00 lbs.	1.400	✓
Wilco	E503000	Lobby	100% Corn	7#	3	Red	No	7/8" Brown	38 1/2"	12	9.00 lbs.	1.400	✓
Wilco	E513500	Toy	Blend	7#	2	Black	No	7/8" Brown	25 3/4"	12	7.00 lbs.	1.114	✓
Wilco	E504500	Whisk	Blend	6#	2	Black	No	Hang Cap	11"	12	6.00 lbs.	0.848	✓
Wilco	E504000	Whisk	100% Corn	6#	2	Red	No	Hang Cap	11"	12	6.00 lbs.	0.848	✓

ANGLE BROOMS

CONTEMPORARY PLASTIC BROOMS

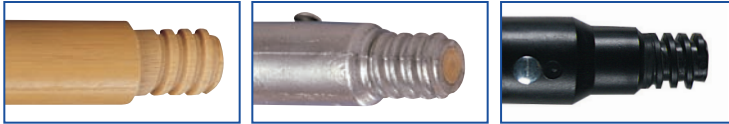

These brooms accept threaded handles only. Found on page 51

[A] HUSKEE™ SWEEP

Stiff black polypropylene fibers for fine to heavy sweeping. Angled design allows you to sweep into corners and hard to reach places. The sweep has a built-in grip brace that allows you to remove the upright handle and use it as a whisk broom. Perfect for Industrial and Food Service applications.



[B] TRI-ANGLE BROOM

The versatile Tri-Angle may be used as a regular broom, a high duster or a whisk broom. Extend the handle and you have a high duster that reaches 10 foot ceilings. Unscrew the handle and you have an ergonomic whisk broom for smaller sweeping jobs.



[C] ANGLED BROOM

Both sizes feature an angled design for sweeping into corners and tight areas and are attached to a 48" long metal handle. The bristles are available with yellow polypropylene flagged or unflagged tips.

Brand	Item #	Description	Bristle Type	Bristle Color	Bristle Trim	Handle Material	Size/Color of Handle	Case Pack	Case Weight	Case Cubic Ft.	Stock Item
Wilco	E515012	Huskee™ Sweep	Flagged Polypropylene	Black/Yellow	6"	Metal	1" x 48" Yellow	6	8.00 lbs.	3.923	✓
Wilco	E505000	Tri-Angle Broom, Complete	Flagged PVC	Yellow	4"	Metal	1" x 31"-58" Black	12	16.00 lbs.	3.900	✓
Wilco	E506000	Tri-Angle Broom, Head Only	Flagged PVC	Yellow	4"	N/A	N/A	12	9.00 lbs.	1.290	✓
Wilco	E507008	Angled Broom, Complete - 8" wide	Flagged PVC	Yellow	5 1/2"	Metal	7/8" x 48" Black	12	12.00 lbs.	3.900	✓
Wilco	E507012	Angled Broom, Complete - 12" wide	Flagged PVC	Yellow	6"	Metal	7/8" x 48" Black	12	15.00 lbs.	3.900	✓
Wilco	E507112	Angled Broom, Complete - 12" wide	Unflagged PVC	Yellow	6"	Metal	7/8" x 48" Black	12	15.00 lbs.	3.900	✓

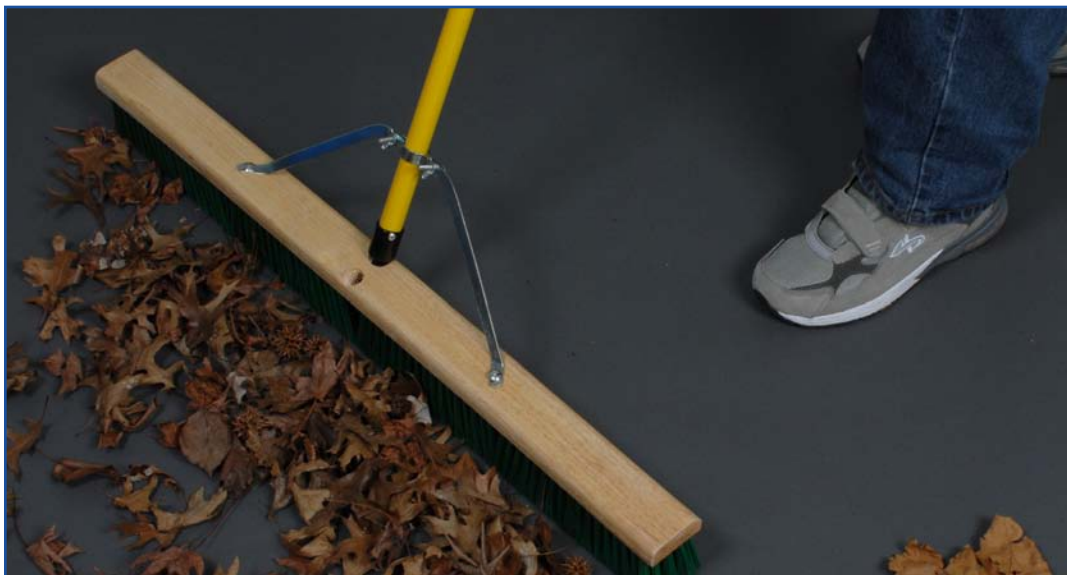

SWEEPS ~ FLOOR & GROUND

Stiffness, durability and cost are just a few characteristics to consider when selecting the right sweep. With a variety of sizes, fibers and choice of lacquered hardwood and structural foam, we offer a sweep for every application. All blocks come with two threaded handle holes. 36" wood sweep also includes handle arm braces for added strength. Sweep handles are sold separately.

Choosing the Best Value in Sweeps

Here's a primer to help you brush up on your bristles! With the abundant number of brush and broom SKUs in this catalog, we can't possibly cover everything - but a good basic understanding of fibers, blocks and construction techniques can go a long way.

The Wilen® Advantage

What makes Wilen brushes better? Everything! From our state-of-the-art, computerized machinery, to our high quality construction, to our breadth of line, you can be assured you'll find the right tool for the job.

Dust It, Spread It, Scrape It, Wash It...

Look to Wilen for products that work. We have the variety and styles for every environment and application.



Nylon

A resilient synthetic fiber that has a high heat tolerance, excellent bend recovery and can be autoclaved. It is available straight, crimped or flagged. Resists acid, heat, oil and most solvents. Used in most scrub brushes.



Polypropylene

A synthetic fiber that is available crimped or straight in a variety of colors. It has a very long life and high resistance to acid and most solvents.



Black Tampico

Comes from the leaf of the cactus-like Lechuguilla plant of Mexico. With a soft to medium texture and good durability, Tampico may be used alone or blended with other materials. Naturally off-white in color, the fibers are dyed black.



White Tampico

Comes from the cactus-like Lechuguilla plant of Mexico. With a soft to medium texture and good durability, Tampico may be used alone or blended with other materials. It has excellent liquid retention and is highly resistant to solvents and chemicals. Original color.



Horsehair

From the tail or mane, has soft to slightly stiff characteristics and offers good texture and resilience. It may be used pure or blended with other materials and is available in black or grey. Used for scratchless cleaning of highly polished areas.



Palmyra

Comes from the base of the leaf stalks of the Palmyra palm of India and Africa. Texture is medium stiff to stiff. Low cost, durability and liquid resistance make it ideal for a wide variety of uses. Comes brown in color.



Palmyra Stalks

Very coarse and durable. Texture is quite stiff. It has the appearance of split bamboo and is primarily used for street brooms.

What does "flagged" mean?

Many brushes have "flagged" (also known as "feathered") bristles. Flagged bristles contain split ends which decrease stiffness and add liquid and dust retention properties. This soft, synthetic fiber is ideal for dusting, fine sweeping of smooth surfaces and washing vehicles without scratching.

Blocks

Fibers are set into either structural foam or wood blocks, both have advantages. More and more people are choosing structural foam due to its obvious advantages—durability, water resistance and its non-warping, non-splintering characteristics. Nevertheless, traditional wood is still widely used.

Push It

There are several different types of floor brushes (or push brooms) available: Floor Sweep for indoor surfaces; Garage Sweep for concrete and outdoor use; and Street Broom for sweeping heavy debris on rough surfaces. In addition, each of these categories contain a variety of styles and sizes. For larger sweeps, our handle braces provide added support and keep the sweep from twisting.

Scrub It

Just as there are many different surfaces to clean, there are many different brushes to accommodate these different needs. What to look for: appropriate fiber stiffness for the job; block or handle ergonomics; and surface coverage. To give synthetic fibers better liquid retention while retaining their superior strength, specify "crimped" fibers.

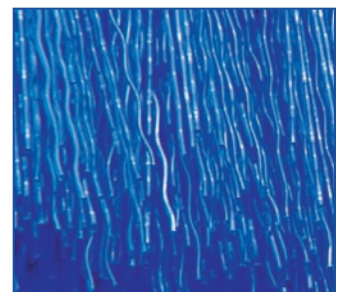

FLOOR SWEEPS

FINE TO MEDIUM FLOOR SWEEPS

Unparalleled quality makes Wilen's floor sweeps the best value. With a variety of sizes, fibers and a choice of lacquered hardwood and structural foam, a sweep is available for every application. All blocks come with two threaded handle holes. 36" wood sweep also includes handle arm braces for added strength. Sweep handles are sold separately.



These brooms accept threaded handles only. Found on page 51

[A] FLAGGED POLYPROPYLENE FINE FLOOR SWEEP

This split-tipped synthetic fiber sweep is excellent for picking up fine particles of dust and dirt on smooth floor surfaces. Grey fibers.

[B] FLAGGED POLYPROPYLENE DOUBLE FILL FLOOR SWEEP

Fine flagged fibers on the outside edge with medium flagged fibers on the inside make this a very efficient sweep for cleaning smooth surfaces like wood, tile and smooth concrete. Water and solvent resistant fibers. Black center fibers with orange casing fibers.

[C] ALL PURPOSE DOUBLE FILL FLOOR SWEEP

Heavy polypropylene center and flagged polypropylene around the outside perimeter to pick up both fine and medium particles. Black center fibers with grey casing fibers.



[A]

F002018



[B]

F003118



[C]

F004018

Brand	Item #	Description	Block	Block Size	Bristle Trim	Case Pack	Case Weight	Case Cubic Ft.	Stock Item
Wilen	F002018	Flagged Polypropylene Fine Floor Sweep	Wood	18"	3"	12	20.00 lbs.	1.750	✓
Wilen	F002024	Flagged Polypropylene Fine Floor Sweep	Wood	24"	3"	12	30.00 lbs.	2.298	✓
Wilen	F002036	Flagged Polypropylene Fine Floor Sweep	Wood	36"	3"	4	24.00 lbs.	1.039	✓
Wilen	F002118	Flagged Polypropylene Fine Floor Sweep	Foam	18"	3"	12	24.00 lbs.	1.750	✓
Wilen	F002124	Flagged Polypropylene Fine Floor Sweep	Foam	24"	3"	12	30.00 lbs.	2.298	✓
Wilen	F003018	Flagged Polypropylene Double Fill Floor Sweep	Wood	18"	3"	12	24.00 lbs.	1.750	✓
Wilen	F003024	Flagged Polypropylene Double Fill Floor Sweep	Wood	24"	3"	12	33.00 lbs.	2.298	✓
Wilen	F003036	Flagged Polypropylene Double Fill Floor Sweep	Wood	36"	3"	4	24.00 lbs.	1.039	✓
Wilen	F003118	Flagged Polypropylene Double Fill Floor Sweep	Foam	18"	3"	12	24.00 lbs.	1.750	✓
Wilen	F003124	Flagged Polypropylene Double Fill Floor Sweep	Foam	24"	3"	12	33.00 lbs.	2.298	✓
Wilen	F004018	All Purpose Double Fill Floor Sweep	Wood	18"	3"	12	24.00 lbs.	1.750	✓
Wilen	F004024	All Purpose Double Fill Floor Sweep	Wood	24"	3"	12	33.00 lbs.	2.298	✓
Wilen	F004036	All Purpose Double Fill Floor Sweep	Wood	36"	3"	4	24.00 lbs.	1.039	✓
Wilen	F004118	All Purpose Double Fill Floor Sweep	Foam	18"	3"	12	24.00 lbs.	1.750	✓
Wilen	F004124	All Purpose Double Fill Floor Sweep	Foam	24"	3"	12	33.00 lbs.	2.298	✓

FLOOR SWEEPS

FINE TO MEDIUM FLOOR SWEEPS



These brooms accept threaded handles. Found on page 51

[A] BLACK TAMPICO FLOOR SWEEP



This full bodied, flexible and long wearing sweep is ideal for industrial or commercial cleaning on concrete, wood or tile floors. Considered the best all-purpose tool for fine to medium clean up jobs. Black fibers.

[B] BLACK POLYPROPYLENE FLOOR SWEEP



All purpose medium sweep for indoor/outdoor cleaning in industrial and commercial settings. Black fibers.

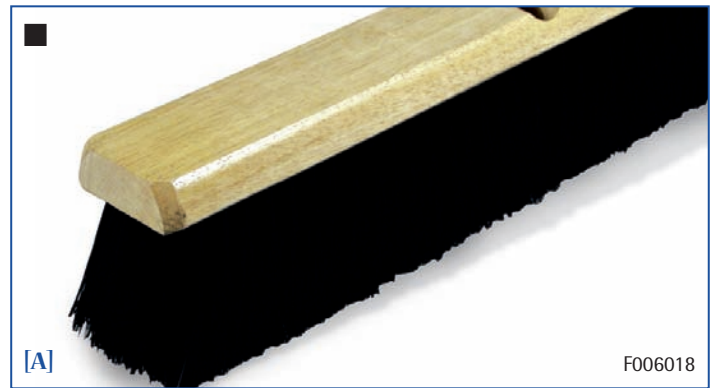

Brand	Item #	Description	Block	Block Size	Bristle Trim	Case Pack	Case Weight	Case Cubic Ft.	Stock Item
Wilco	F006018	Black Tampico Floor Sweep	Wood	18"	3"	12	25.00 lbs.	1.750	✓
Wilco	F006024	Black Tampico Floor Sweep	Wood	24"	3"	12	30.00 lbs.	2.298	✓
Wilco	F006036	Black Tampico Floor Sweep	Wood	36"	3"	4	24.00 lbs.	1.039	✓
Wilco	F006118	Black Tampico Floor Sweep	Foam	18"	3"	12	25.00 lbs.	1.750	✓
Wilco	F006124	Black Tampico Floor Sweep	Foam	24"	3"	12	30.00 lbs.	2.298	✓
Wilco	F007018	Black Polypropylene Floor Sweep	Wood	18"	3"	12	24.00 lbs.	1.750	✓
Wilco	F007024	Black Polypropylene Floor Sweep	Wood	24"	3"	12	35.00 lbs.	2.298	✓
Wilco	F007036	Black Polypropylene Floor Sweep	Wood	36"	3"	4	24.00 lbs.	1.039	✓
Wilco	F007118	Black Polypropylene Floor Sweep	Foam	18"	3"	12	24.00 lbs.	1.750	✓
Wilco	F007124	Black Polypropylene Floor Sweep	Foam	24"	3"	12	35.00 lbs.	2.298	✓

GARAGE SWEEPS

HEAVY-DUTY, INDOOR / OUTDOOR FLOOR SWEEPS

These medium to heavy sweeps feature coarser fibers than regular floor sweeps. This allows them to sweep heavier debris and perform better on rough surfaces like driveways. Available with lacquered hardwood and structural foam blocks, these long-wearing sweeps are ideal for outside sweeping, basements, warehouses and other rough surface areas. 30" and 36" wood sweeps include handle braces. Sweep handles are sold separately.



These brooms accept threaded handles. Found on page 51

[A] HEAVY POLYPROPYLENE GARAGE SWEEP



This durable, heavy-duty sweep is great for sweeping on wet or dry surfaces. Recommended for places like streets, sidewalks, warehouses, driveways or basements. Also good for sweeping light snow. Green fibers.



[B] PALMYRA GARAGE SWEEP



The ideal sweep for coarse, heavy dirt on wet or dry surfaces. Ideal on driveways, basements, sidewalks and garages. Natural fibers.

[C] CRIMPED POLYPROPYLENE GARAGE SWEEP



Excellent for commercial applications. Recommended for gas stations, food service, plants and other commercial buildings. Solvent resistant fibers add to longer life. Maroon/brown fibers.



Brand	Item #	Description	Block	Block Size	Bristle Trim	Case Pack	Case Weight	Case Cubic Ft.	Stock Item
Wilco	F101018	Heavy Polypropylene Garage Sweep	Wood	18"	3"	12	26.00 lbs.	1.750	✓
Wilco	F101024	Heavy Polypropylene Garage Sweep	Wood	24"	3"	12	35.00 lbs.	2.298	✓
Wilco	F101036	Heavy Polypropylene Garage Sweep	Wood	36"	3"	4	20.00 lbs.	1.039	✓
Wilco	F101118	Heavy Polypropylene Garage Sweep	Foam	18"	3"	12	26.00 lbs.	1.750	✓
Wilco	F101124	Heavy Polypropylene Garage Sweep	Foam	24"	3"	12	35.00 lbs.	2.298	✓
Wilco	F102018	Palmyra Garage Sweep	Wood	18"	4"	12	27.00 lbs.	1.750	✓
Wilco	F102024	Palmyra Garage Sweep	Wood	24"	4"	12	37.00 lbs.	2.298	✓
Wilco	F102030	Palmyra Garage Sweep	Wood	30"	4"	1	4.00 lbs.	0.450	✓
Wilco	F102036	Palmyra Garage Sweep	Wood	36"	4"	1	5.00 lbs.	0.376	✓
Wilco	F103018	Crimped Polypropylene Garage Sweep	Wood	18"	3"	12	26.00 lbs.	1.750	✓
Wilco	F103024	Crimped Polypropylene Garage Sweep	Wood	24"	3"	12	35.00 lbs.	2.298	✓
Wilco	F103036	Crimped Polypropylene Garage Sweep	Wood	36"	3"	4	20.00 lbs.	1.039	✓
Wilco	F103118	Crimped Polypropylene Garage Sweep	Foam	18"	3"	12	26.00 lbs.	1.750	✓
Wilco	F103124	Crimped Polypropylene Garage Sweep	Foam	24"	3"	12	35.00 lbs.	2.298	✓

STREET & PATIO SWEEPS

COURSE OUTDOOR SWEEP

For extra rough surfaces and heavy debris, these street and patio sweeps are perfect. Coarse, extra long fibers are great for a variety of heavy-duty, outdoor applications. Hardwood blocks have two tapered handle holes. Order handles separately.



Accepts tapered handles.
Found on page 51

[A] PALMYRA STALKS STREET SWEEP



This very coarse, long-lasting and durable fiber is perfect for any rugged sweeping. Ideal for streets, concrete and barns. Can also be used on any wet or dry surface. Natural fibers.

ASSEMBLED FLOOR & GARAGE SWEEPS

These high quality sweeps provide long lasting performance. Features include a heavy-duty zinc cast handle connector, durable 1/8" x 60" hardwood handle and a double-lacquered, smooth finish hardwood block. 12 gauge steel braces stabilize the sweep head. Available in a variety of sizes.

[B] MEDIUM POLYPROPYLENE ASSEMBLED FLOOR SWEEP



This all purpose medium floor sweep is great for indoor/outdoor cleaning in industrial and commercial areas. Blue fibers.

[C] HEAVY POLYPROPYLENE ASSEMBLED GARAGE SWEEP



This heavy-duty assembled sweep is great for sweeping on wet and dry surfaces. Ideal for streets, driveways and basements. Green fibers.

HANDLE BRACES

EXTRA SUPPORT HANDLE HARDWARE

[D] HANDLE BRACE



Braces provide support, reduce breakage and add life to the handles. Angle braces provide extra support for wide sweeps. Available for all 24" wood block floor and garage sweeps. Our 30" and 36" sweeps include angle braces.



[A]

F201016



[B]

F522480



[C]

F532480



[D]

M202000

Brand	Item #	Description	Block	Block Size	Bristle Trim	Case Pack	Case Weight	Case Cubic Ft.	Stock Item
Wilco	F201016	Palmyra Stalks Street Sweep	Wood	16"	6 1/2"	6	19.00 lbs.	1.750	✓
Wilco	F521880	Medium Polypropylene Assembled Floor Sweep	Wood	18"	4"	4	16.00 lbs.	7.965	✓
Wilco	F522480	Medium Polypropylene Assembled Floor Sweep	Wood	24"	4"	4	19.00 lbs.	10.137	✓
Wilco	F531880	Heavy Polypropylene Assembled Garage Sweep	Wood	18"	4"	4	19.00 lbs.	12.335	✓
Wilco	F532480	Heavy Polypropylene Assembled Garage Sweep	Wood	24"	4"	4	23.00 lbs.	10.137	✓
Wilco	M202000	Handle Brace	---	---	---	12	5.00 lbs.	0.469	✓

POLES & HANDLES

Our selection of professional quality handles includes threaded and tapered styles in a variety of sizes. From lightweight to extra durable, you will find the handle that best fits your needs. Use our Telescopic Poles with our window squeegees, brushes and dusters.



UTILITY HANDLES

[A] THREADED WOOD HANDLE



Bamboo handle stands up to heavy use. Standard threads fit many products.

[B] METAL THREADED WOOD HANDLE



Available in two sizes, this bamboo handle is great for use with sweeps and scrub brushes. Comes in lacquered hardwood.

[C] PLASTIC THREADED FIBERGLASS HANDLE



Ideal for wet mops, sweeps and brushes. Durable handle is for heavy usage. This yellow fiberglass handle comes with a black plastic threaded cap.

[D] TAPERED WOOD HANDLE



Constructed from bamboo, a natural hardwood, this durable handle is available in two different sizes. Tapered end is great for quick and easy changes.

[E] METAL HANDLES W/ THREADED METAL HEX TIP



Handle stands up to heavy use. Standard threads fit many products.

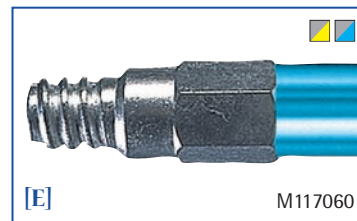
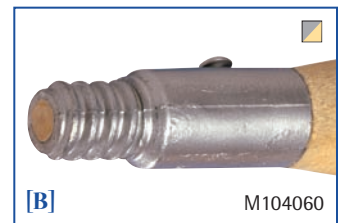
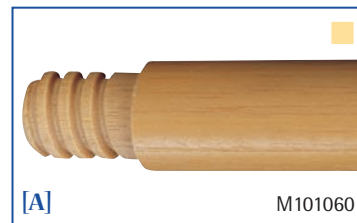

Brand	Item #	Description	Head	Shaft	Case Pack	Case Weight	Case Cubic Ft.	Stock Item
Wilco	M101060	Threaded Wood Handle	Wood	1 5/16" x 60" Wood	12	12.00 lbs.	5.166	✓
Wilco	M104060	Metal Threaded Wood Handle	Metal	1 5/16" x 60" Wood	12	14.00 lbs.	5.166	✓
Wilco	M105060	Metal Threaded Wood Handle	Metal	1 1/8" x 60" Wood	12	20.00 lbs.	5.166	✓
Wilco	M106060	Plastic Threaded Fiberglass Handle	Plastic	1" x 60" Fiberglass	12	16.00 lbs.	5.166	✓
Wilco	M109054	Tapered Wood Handle	Wood	1 1/8" x 54" Wood	12	15.00 lbs.	0.562	✓
Wilco	M109060	Tapered Wood Handle	Wood	1 1/8" x 60" Wood	12	17.00 lbs.	0.520	✓
Wilco	M117060	Metal Handle w/ Threaded Metal Hex Tip	Metal	1" x 60" Metal / Blue	12	16.00 lbs.	0.661	✓
Wilco	M119060	Metal Handle w/ Threaded Metal Hex Tip	Metal	1" x 60" Metal / Yellow	12	16.00 lbs.	0.661	✓

POLES

[A] TELESCOPIC POLES

Aluminum telescopic poles in two or three pieces are used for high reach and angled windows. Reduces the need for scaffolds or ladders, increasing efficiency. Simply twist to extend or to retract.

Brand	Item #	Description	Max. Length	Case Pack	Case Weight	Case Cubic Ft.	Stock Item
Continental	2550-08	2 sections, 4'-8'	8'	3	11.00 lbs.	1.100	✓
Continental	2550-12	2 sections, 6'-12'	12'	3	5.00 lbs.	2.828	✓
Continental	2550-15	3 sections, 5'7"-15'	15'	3	29.88 lbs.	1.720	✓
Continental	2550-18	2 sections, 6'-18'	18'	3	26.88 lbs.	2.520	✓
Continental	2550-24	3 sections, 8'-24'	24'	3	9.60 lbs.	1.500	✓
Continental	2551	Threaded End Cone	- - -	3	25.02 lbs.	3.240	✓



TOOL HANGERS

Keeping your cleaning tools organized saves time and money. Our tool hangers provide fast and easy storage, allowing you to spend less time searching for your tools.

[B] HANDY-HOLD METAL MOP & BROOM HOLDER

Steel with rubber cam, grips 7/8" to 1 1/4" diameter handles. Excellent for mops, brooms and tools. Easy to use. Push handle up and into Hanger and the rubber cam will adjust and holds tightly in place. To remove, simply push up to release and remove.



[C] HOODED ARRANGER TOOL HANGER

Mop, broom and tool holder is made of high-impact plastic. Patented rubber grips and tension adjustment. Frees floor space. Wet mops dry quicker when suspended. Save time and end storage clutter.

Brand	Item #	Description	Case Pack	Case Weight	Case Cubic Ft.	Stock Item
Continental	515	Handy-Hold Metal Mop & Broom Holder	12	2.36 lbs.	0.040	✓
Continental	516	Hooded Arranger Tool Hanger, 18"	1	1.41 lbs.	0.130	✓
Continental	517	Hooded Arranger Tool Hanger, 36"	1	2.32 lbs.	0.260	✓

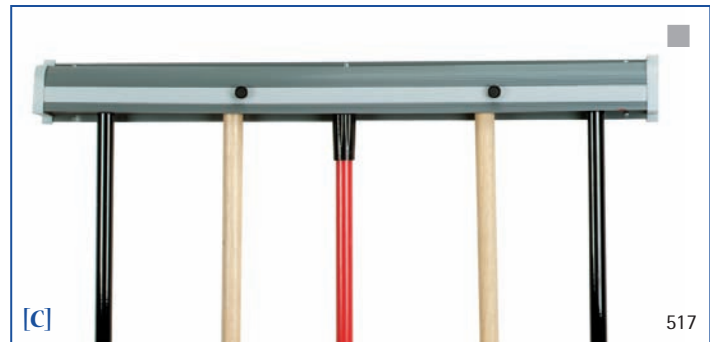



FLOOR PADS

Glit floor pads are designed to give superior performance based on the application being performed. Low speed, conventional pads are used wet or dry, and are designed to work in a variety of settings including institutional, commercial and industrial applications, while increasing productivity on the job.

GLIT FLOOR PADS

Glit® offers the most diverse and complete line of high quality and functional floor pads in the market, today.

Available in a Variety of Shapes and Sizes:

- Discs
- Rectangles
- Custom, Non-Traditional Shapes
- Many Sizes

Specific Pads for a Variety of Applications:

- Stripping
- Scrubbing
- Deep Cleaning
- Daily Maintenance
- Spray Buffing
- Burnishing
- Polishing ... Glit® does it all!!

A Pad for Every Use!

Today's floor types and the programs used to maintain them are as diverse as ever. Being able to provide any type of floor pad, for any type of application, to fit any type of floor machine is one of many advantages for our Glit® distributors around the globe.



EARTHTONE™

Glit® floor pads are 'green'

Made with 100% recycled fiber; packaged with recycled corrugate, **Glit® floor pads are as 'green' as you will find.** Our focus on sustainability runs throughout our entire organization and manufacturing facility. Our plants exceed the EPA Clean Air Permit requirements and have been modified with in-house water treatment facilities, reducing our water flow by 75%. Our state-of-the-art Regenerative Thermal Oxidizer (RTO) exceeds US requirements for air emissions.



How Glit® Floor Pads are Made

The Glit® manufacturing facility is 100% dedicated to the production of non-woven floor and hand pad material. All Glit® products are made in the USA with high-quality production and performance standards.

Glit's open web design optimizes performance, allowing the floor pads to:

- Hold more chemicals within the pad, limiting surface load
- Cushions the machine and hugs uneven floors
- Ventilate the heat generated with more air flow through the pad

Innovation has brought new floor types, new machinery and new chemicals - and Glit® has continuously brought new floor pads to bring it all together. In addition to standard resins and abrasives used in conventional floor pads, Glit's extensive line features pads with innovative fibers and abrasives for the ultimate choice of floor care delivery.



Conventional Floor Pads

Our floor pads are resilient, long-lasting and easy to clean. Pads are color-coded for easy identification. Manufactured for use with machines that operate at 175 - 350 R.P.M. Glit® offers a variety of options for stripping, scrubbing, cleaning, spray buffing and polishing.



Ultra High Speed (UHS) Burnishing Pads

As a leading supplier of floor pads, we actively research to determine the type of pad needed for the wet-look shine, and how to obtain this look. We know that more than one type of floor pad is needed due to the variety of floor and chemical types. Floor surfaces and preparation procedures are not all the same - they vary with the type of finish used, machine pad weight, pad speed and environmental conditions. A series of specially manufactured pads with varying degrees of aggressiveness should be made available to end users. A selection from our line of pads will produce and maintain the wet-look shine on various floor surfaces utilizing the different types of finishes and machines operating at 1,000 to 3,000 R.P.M.

FLOOR PAD USAGE TIPS

What is a Floor Pad?

There are four main components used to produce any type of floor pad. These include: fiber, binder, abrasives and pigment or color. When you are helping your customers select the best floor care program customized for their situation, it is very helpful to understand the basic components of each floor pad and why some are better suited for different floor types, machine applications, etc. In addition to the information contained in this catalog, contact your Glit® Sales Representative for more detailed information available on our individual Product Specification Sheets.

How do you choose the proper aggressiveness?

This is a key driver for designing a successful floor care program. The proper combination of fiber, resin and abrasives are what determine the aggressiveness of a floor pad. It is always best to use the least aggressive pad necessary to get the job done. Floor care can be both a science and an art. While there are many guiding principles to use when choosing the right floor pad, the best approach is to test more than one pad to find the best fit. The Floor Pad Usage Guide provided on page 55 is a great place to start.

Why do you want floor pads with an open web design?

Floor pads made with an open web design offer many advantages, including but not limited to:

































- Holds more stripper or cleaning solution, providing more efficiency
- Cushions the machine better; this helps prevent the machine from bottoming out
- Hugs uneven floors
- Excels at soil removal without clogging, preventing premature surface load

What else should you consider?

Remember that floor pads are not the only determinant of success. The chemicals and equipment used, along with user competence and the floor itself are all factors to consider when developing a floor care program. For assistance, contact your Glit® Distributor or Sales Representative for additional expertise and guidance.

Use our Application Guide (below), to help select the right floor pad for your needs.

FLOOR PAD APPLICATION GUIDE • EARTHTONE™

Application	Conventional Floor Pads				UHS Floor Pads		
	Stripping (18-36 months)	Scrubbing (Quarterly)	Cleaning (Daily)	Spray Buffing (1-5 week)	UHS Burnishing Frequent (1-5 x week)	UHS Burnishing Moderate (2-3 x week)	UHS Burnishing Infrequent (1 x week)
Floor Type	Resilient Floors VCT, VAT, Sheet Vinyl	Resilient Floors VCT, VAT, Sheet Vinyl	Resilient Floors VCT, VAT, Sheet Vinyl	Resilient Floors VCT, VAT, Sheet Vinyl	Resilient Floors VCT, VAT, Sheet Vinyl	Resilient Floors VCT, VAT, Sheet Vinyl, Linoleum	Resilient Floors VCT, VAT, Sheet Vinyl, Linoleum
	Non-Resilient Floors Terrazzo, Granite, Concrete Note: Do not strip linoleum	Non-Resilient Floors Terrazzo, Granite, Concrete	Non-Resilient Floors Terrazzo, Granite, Concrete	Non-Resilient Floors Terrazzo, Granite	Non-Resilient Floors Terrazzo, Granite, Concrete, Stone Note: 1500 RPM max on linoleum	Non-Resilient Floors Terrazzo, Granite, Concrete, Stone Note: 1500 RPM max on linoleum	Non-Resilient Floors Terrazzo, Granite, Concrete, Stone Note: Do not strip linoleum
Powered Equipment	Standard Speed Floor Machine 175-350 R.P.M.	Standard Speed Floor Machine 175-350 R.P.M.	Standard Speed Floor Machine 175-350 R.P.M.	Standard Speed Floor Machine 175-350 R.P.M.	Propane, Battery, Electric Burnishers 1,000-3,000 R.P.M.	Propane, Battery, Electric Burnishers 1,000-3,000 R.P.M.	Propane, Battery, Electric Burnishers 1,000-3,000 R.P.M.
Polymer	---	---	---	---	Soft	Moderate-Hard	Hard
Floor Pad Options	 Emerald II	 Green Scrubbing	 Coral	 Red	 Jackeroo Lite	 CocoPad	 100-D
	 Safire 66	 Blue Cleaner	 Red	 Tan	 Beige	 Buckaroo	 CocoPad
	 Black	 Coral	 White	 White	 Aqua	 Jackeroo	 Buckaroo
	 Brown				 Blue Ice	 Jackeroo Lite	 Jackeroo
	 Green Floor Prep Pad				 Joey	 Coral	 Jackeroo Lite
						 Champagne	 Champagne
						 Peach	
						 Beige	

CONVENTIONAL THICKLINE / ULTRA VALULINE® PADS



Emerald II Stripping:
Highly abrasive for maximum stripping power.

Safire® 66 Stripping:
Durable and aggressive for tough stripping.

Black Stripping:
For long-lasting, heavy-duty stripping.

Brown Stripping:
For fast, uniform stripping, wet or dry.

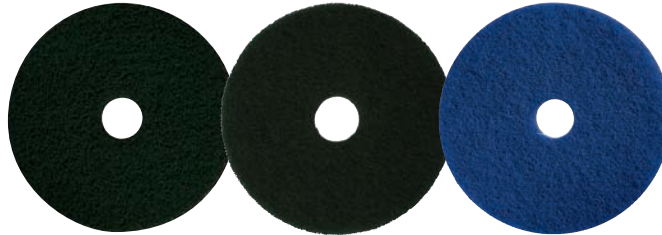

"Green" Floor Prep Pad:
Chemical-free stripping pad, use wet or dry.

Green Scrubbing:
Wet, heavy-duty scrubbing.

Blue Cleaner:
Wet, light-duty scrubbing & cleaning.

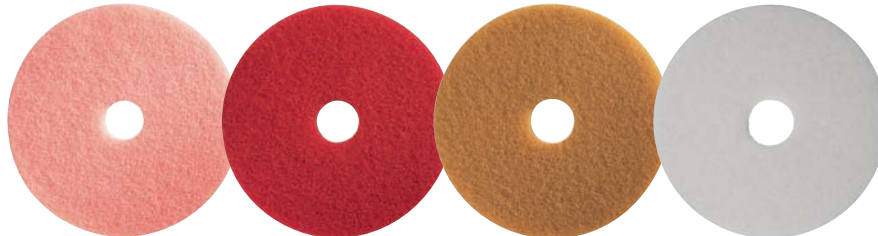

Coral Pre-Burnishing:
Multi-use with automatic scrubbers.

Red Buffing:
For dry or spray buffing or light-duty scrubbing.

Tan Buff Polishing:
For dry polishing buffable synthetic finishes.

White Super Polishing:
For dry polishing or with fine water mist to ensure high gloss.

STRIPPING PADS ~ Use on Machines Operating at 175-350 R.P.M.

Intended Use:

To remove floor finish and soil prior to applying new floor finish. Can be used on most resilient and stone floors that have a topical coating.

Not Intended for Use:

On linoleum or marble. Always follow proper floor stripping guidelines.

Unless Otherwise Noted in Chart:

Floor pads have a 3.25" Center Hole and come 5 per case pack. Round pads are available in smaller sizes upon request.

[A] GLIT® EMERALD II STRIPPING PAD EARTHTONE™

Aggressive, heavy-duty pad for maximum wet stripping performance. Quickly cuts through old finish, dirt and build-up.

[B] GLIT® SAFIRE® STRIPPING PAD EARTHTONE™

Wet stripping pad. Quickly cuts through old finish, dirt and build-up. Durable and tough for increased efficiency.



Size	Emerald II Item #	Case Weight	Case Cu. Ft.	Stock Item	Safire 66® Item #	Case Weight	Case Cu. Ft.	Stock Item
13"	43213	2.00 lbs.	0.669		23454	2.00 lbs.	0.669	
14"	43214	2.60 lbs.	0.669		23476	2.40 lbs.	0.669	
15"	43215	3.40 lbs.	0.867		23477	3.00 lbs.	0.867	
16"	43216	3.80 lbs.	0.867		23478	3.40 lbs.	0.867	
17"	43217	4.28 lbs.	1.089	✓	23455	3.53 lbs.	1.089	✓
18"	43218	4.60 lbs.	1.089		23471	4.20 lbs.	1.089	
19"	43219	5.20 lbs.	1.354	✓	23466	4.72 lbs.	1.354	✓
20"	43220	5.80 lbs.	1.354	✓	23438	5.04 lbs.	1.354	✓
21"	43221	6.20 lbs.	1.611		23479	5.80 lbs.	1.611	
22"	43222	6.40 lbs.	1.611		23589	6.00 lbs.	1.611	
23"	43223	6.60 lbs.	1.911		29588	6.20 lbs.	1.911	
24"	43224	6.80 lbs.	1.911		29061	6.40 lbs.	1.911	
12" x 18"	24470	4.25 lbs.	1.120		24471	2.06 lbs.	1.120	
14" x 20"	24426	5.30 lbs.	1.338		24429	3.57 lbs.	1.338	
14" x 28"	24427	7.45 lbs.	2.586		24430	5.00 lbs.	2.586	
14" x 32"	24428	8.50 lbs.	1.707		24431	7.00 lbs.	1.707	
*14" x 32"	*26710	17.00 lbs.	2.949		---	---	---	

THESE PADS COME 10 PER CASE:
*26710 - 14" x 32" Emerald



Git/Microtron
DELIVERY
In Stock Products:
Available to ship within
two business days
Non-Stock Products:
Available to ship within
five business days

STRIPPING PADS ~ Use on Machines Operating at 175-350 R.P.M.

Intended Use:

To remove floor finish and soil prior to applying new floor finish. Can be used on most resilient and stone floors that have a topical coating.

Not Intended for Use:

On linoleum or marble. Always follow proper floor stripping guidelines.

Unless Otherwise Noted in Chart:

Round Black and Brown floor pads have a 3.25" Center Hole and come 5 per case pack. Round "Green" Floor Prep pads have a 3.25" Center Hole and come 10 per case pack. Round pads are available in smaller sizes upon request.

[A] GLIT® BLACK STRIPPING PAD EARTHTONE™

Heavy-duty pad with excellent cutting ability for wet stripping performance. High resiliency helps to conform to uneven floors.

[B] GLIT® BROWN STRIPPING PAD EARTHTONE™

Slightly less aggressive wet stripping pad. Cuts through old finish, dirt and build-up. High resiliency helps to conform to uneven floors.



CHEMICAL FREE STRIPPING PADS ~

Use with Standard Speed Floor Machines, Automatic Scrubbers and Oscillating Floor Equipment.

[C] GLIT® "GREEN" FLOOR PREP PAD EARTHTONE™

Use for dry stripping or scrubbing. Removes 1-3 coats of soiled or abraded floor finish. The pad can also be used wet.



Size	Black Item #	Case Weight	Case Cu. Ft.	Stock Item	Brown Item #	Case Weight	Case Cu. Ft.	Stock Item
12"	20006	2.10 lbs.	0.690	✓	---	---	---	
13"	20007	2.20 lbs.	0.669	✓	20241	2.00 lbs.	0.669	
14"	20008	2.60 lbs.	0.669	✓	20242	2.16 lbs.	0.669	
15"	20009	3.28 lbs.	0.867	✓	20243	2.35 lbs.	0.867	
16"	20010	3.76 lbs.	0.867	✓	20260	2.62 lbs.	0.867	
17"	20011	4.04 lbs.	1.089	✓	20244	2.84 lbs.	1.089	✓
18"	20012	4.56 lbs.	1.089	✓	20245	3.40 lbs.	1.089	
19"	20013	5.00 lbs.	1.354	✓	20246	4.00 lbs.	1.354	
20"	20014	5.68 lbs.	1.354	✓	20247	4.80 lbs.	1.354	✓
21"	20015	6.04 lbs.	1.611	✓	20248	5.10 lbs.	1.611	
22"	20016	6.10 lbs.	1.611		20249	5.30 lbs.	1.611	
23"	20017	6.50 lbs.	1.911		20250	5.50 lbs.	1.911	
24"	20018	6.70 lbs.	1.911		20251	6.10 lbs.	1.911	
12" x 18"	21493	4.00 lbs.	1.120		24472	4.10 lbs.	1.120	
14" x 20"	24406	5.07 lbs.	1.338		25783	5.07 lbs.	1.338	✓
14" x 28"	24407	7.10 lbs.	2.586		25784	7.10 lbs.	2.586	✓
14" x 32"	24408	8.11 lbs.	1.707		---	---	---	
*14" x 32"	*26651	16.22 lbs.	2.949		24473	8.11 lbs.	1.710	

THESE PADS COME 10 PER CASE:
*26651 - 14" x 32" Black



Size	Item #	Case Weight	Case Cu. Ft.	Stock Item	Size	Item #	Case Weight	Case Cu. Ft.	Stock Item
13"	21310	2.24 lbs.	0.690		20"	21316	4.96 lbs.	1.370	
14"	21311	2.38 lbs.	0.690		12" x 18"	21317	2.51 lbs.	1.120	
15"	21312	2.55 lbs.	0.890		14" x 20"	21318	4.91 lbs.	1.338	
16"	21313	3.18 lbs.	0.890		14" x 28"	21919	3.50 lbs.	2.630	
17"	21314	3.35 lbs.	1.120		14" x 32"	21320	7.57 lbs.	1.707	
19"	21315	4.74 lbs.	1.370						



SCRUBBING PADS ~ Use on Machines Operating at 175-350 R.P.M.

Intended Use:
 To provide a clean and attractive condition to all hard surface floors and prepare floors for a fresh coat of paint.

Unless Otherwise Noted in Chart:
 Floor pads have a 3.25" Center Hole and come 5 per case pack. Round pads are available in smaller sizes upon request.

[A] GLIT® GREEN SCRUBBING PAD EARTHTONE™
 Heavy-duty, deep scrubbing pad is ideal for scrub and recoat applications. Removes worn or damaged floor finish.

[B] GLIT® BLUE CLEANER PAD EARTHTONE™
 Moderate cleaning pad for scrub and recoat applications or light wet spray cleaning of floors.



Size	Green Item #	Case Weight	Case Cu. Ft.	Stock Item	Blue Item #	Case Weight	Case Cu. Ft.	Stock Item
13"	20124	1.80 lbs.	0.669	✓	20202	1.60 lbs.	0.669	✓
14"	20125	2.40 lbs.	0.669	✓	20203	1.72 lbs.	0.669	✓
15"	20126	2.60 lbs.	0.867	✓	20204	2.08 lbs.	0.867	✓
16"	20127	2.80 lbs.	0.867	✓	20205	2.40 lbs.	0.867	✓
17"	20128	3.00 lbs.	1.089	✓	20206	2.60 lbs.	1.089	✓
18"	20129	3.93 lbs.	1.089		20207	2.90 lbs.	1.089	
19"	20130	4.52 lbs.	1.354	✓	20208	3.10 lbs.	1.354	
20"	20131	4.63 lbs.	1.354	✓	20209	3.40 lbs.	1.354	✓
21"	20132	4.75 lbs.	1.611		20210	3.65 lbs.	1.611	
22"	20133	5.00 lbs.	1.611		20211	4.00 lbs.	1.611	
23"	20134	5.30 lbs.	1.911		20212	4.20 lbs.	1.911	
24"	20135	6.00 lbs.	1.911		20213	4.50 lbs.	1.911	
12" x 18"	21747	4.00 lbs.	1.120		24474	2.88 lbs.	1.120	
14" x 20"	24417	3.60 lbs.	1.338		24409	3.07 lbs.	1.338	
14" x 28"	24418	5.00 lbs.	2.586		24410	4.30 lbs.	2.586	
14" x 32"	24419	5.70 lbs.	1.707		24411	4.91 lbs.	1.707	

MULTI-PURPOSE, DAILY CLEANING PADS ~
 Use on Machines Operating at 175-1,500 R.P.M.

Intended Use:
 The Multi-Purpose Coral Pad can be used for daily light cleaning, dry or wet spray buffing and for polishing applications. A virtual "mistake-free" alternative for daily maintenance programs. Can also be used on Automatic Scrubbers.

Unless Otherwise Noted in Chart:
 Floor pads have a 3.25" Center Hole and come 5 per case pack. Round pads are available in smaller sizes upon request.

[C] GLIT® CORAL PRE-BURNISHING PAD EARTHTONE™
 A great alternative often used to simplify daily maintenance programs by reducing the need for numerous pads. Works well with all floor types.

Size	Item #	Case Weight	Case Cu. Ft.	Stock Item	Size	Item #	Case Weight	Case Cu. Ft.	Stock Item
13"	25513	1.60 lbs.	0.669		18"	25518	3.10 lbs.	1.089	
14"	21512	1.81 lbs.	0.669		20"	25520	3.40 lbs.	1.354	
15"	25515	2.20 lbs.	0.867		21"	25521	3.60 lbs.	1.611	
16"	25516	2.35 lbs.	0.867		22"	25522	3.75 lbs.	1.611	
17"	25517	2.50 lbs.	1.089		24"	25524	4.10 lbs.	1.911	

Glit/Microtron
DELIVERY
In Stock Products:
 Available to ship within two business days
Non-Stock Products:
 Available to ship within five business days

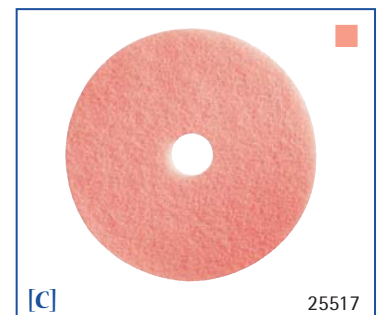

BUFFING PADS ~ Use on Machines Operating at 175-350 R.P.M.

Intended Use:

RED: Ideal for spray buffing and daily cleaning to remove soil and provide a clean, sanitary and attractive condition to hard floor surfaces.

WHITE: For wet or dry buffing soft floor finish.

TAN: For use with floor finish that requires wet or dry buffing.

Unless Otherwise Noted in Chart:

Floor pads have a 3.25" Center Hole and come 5 per case pack. Round pads are available in smaller sizes upon request.

[A] GLIT® RED SPRAY BUFFING PAD EARTHTONE™

A conventional, multi-purpose pad for wet and dry buffing and daily cleaning.

[B] GLIT® WHITE SUPER POLISHING PAD EARTHTONE™

A non-aggressive pad for polishing a clean, dry floor.

[C] GLIT® TAN BUFF POLISHING PAD EARTHTONE™

A conventional spray buff pad made with rubberized resins for wet or dry buffing.

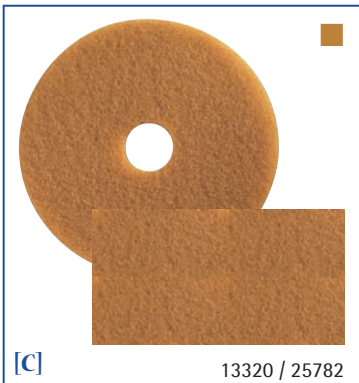
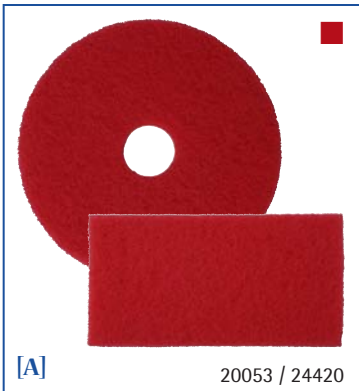

Size	Red Item #	Case Weight	Case Cu. Ft.	Stock Item	White Item #	Case Weight	Case Cu. Ft.	Stock Item	Tan Item #	Case Weight	Case Cu. Ft.	Stock Item
12"	20045	1.82 lbs.	0.690	✓	14412	1.25 lbs.	0.690		---	---	---	
13"	20046	1.60 lbs.	0.669	✓	14413	1.40 lbs.	0.669	✓	13313	1.55 lbs.	0.669	
14"	20047	1.80 lbs.	0.669	✓	14414	1.60 lbs.	0.669	✓	13314	1.67 lbs.	0.669	
15"	20048	2.16 lbs.	0.870	✓	14415	1.78 lbs.	0.867	✓	13315	2.00 lbs.	0.867	
16"	20049	2.28 lbs.	0.890	✓	14416	1.92 lbs.	0.867	✓	13316	2.16 lbs.	0.867	
17"	20050	2.33 lbs.	1.120	✓	14417	2.10 lbs.	1.089	✓	13317	2.20 lbs.	1.089	
18"	20051	3.05 lbs.	1.089	✓	14418	2.40 lbs.	1.089	✓	13318	2.50 lbs.	1.089	
19"	20052	3.20 lbs.	1.354	✓	14419	2.48 lbs.	1.354	✓	13319	2.96 lbs.	1.354	✓
20"	20053	3.40 lbs.	1.354	✓	14420	2.80 lbs.	1.354	✓	13320	3.16 lbs.	1.354	✓
21"	20054	3.80 lbs.	1.611		14421	3.00 lbs.	1.611	✓	13321	3.30 lbs.	1.611	
22"	20055	4.20 lbs.	1.611		14422	3.35 lbs.	1.611		13322	3.50 lbs.	1.611	
23"	20056	4.40 lbs.	1.911		14423	3.70 lbs.	1.911		13323	3.60 lbs.	1.911	
24"	20057	4.60 lbs.	1.911		14424	3.90 lbs.	1.911		13324	3.80 lbs.	1.911	
12" x 18"	22102	3.00 lbs.	1.120		14438	2.39 lbs.	1.120		13338	2.50 lbs.	1.120	
14" x 20"	24420	2.82 lbs.	1.338		24423	2.70 lbs.	1.338		25782	2.82 lbs.	1.338	
14" x 28"	24421	3.22 lbs.	2.586		24424	3.80 lbs.	2.586		24475	3.95 lbs.	2.590	
14" x 32"	24422	4.51 lbs.	1.707		24425	4.30 lbs.	1.707		24476	4.52 lbs.	1.710	
14" x 32"	*26650	9.02 lbs.	2.949		*26649	8.60 lbs.	2.949		---	---	---	

THESE PADS COME 10 PER CASE:
 *26650 - 14" x 32" Red, *26649 - 14" x 32" White



Glit/Microtron®
DELIVERY
In Stock Products:
 Available to ship within
two business days
Non-Stock Products:
 Available to ship within
five business days

ULTRA HIGH SPEED BURNISHING PADS



100-D Neutral Poly Thermal:
Aggressive burnishing pad to use on medium to hard finishes.

CocoPad®:
Pad has natural lubricating factors - this pad is both organic and biodegradable.

Buckaroo®:
A natural hair burnishing pad with binder that is hard and aggressive. Ideal for electric and battery powered machines.

Jackeroo®:
A blend of synthetic fibers and natural hair. Pads last longer with the added benefit of the lubricating effect of a hair pad.

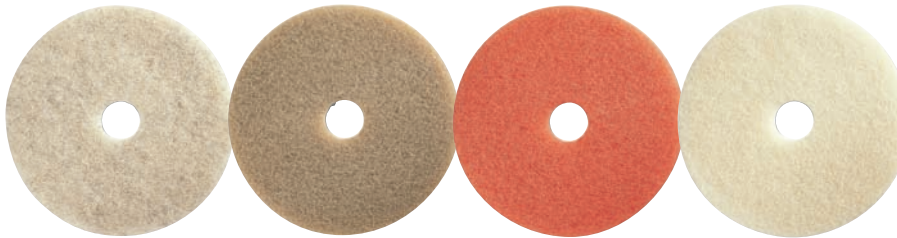

Jackeroo® Lite:
This exceptional floor pad effectively combines natural hair and fiber in a new, advanced way, bringing out the gloss on softer, more buffable floor finishes. It's the ultimate UHS tool.

Champagne:
A soft-textured pad with a rubberized binder for dry burnishing and buffing.

Peach:
A mildly aggressive spray buffing pad that is an excellent cleaner and shiner. Can be used with an automatic scrubber for cleaning.

Beige:
A moderate soft burnishing pad for a high gloss on softer finishes.

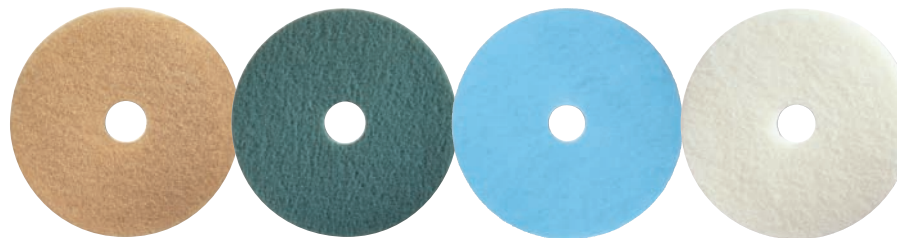

UHS Tan:
Minimize machine drag while producing a wet look gloss. Especially effective on medium to hard finishes.

UHS Aqua:
Superior soft pad that lightly polishes the floor for a high gloss appearance.

Blue Ice®:
For deep and lasting shine. Soft binders with fine synthetic fiber create a super soft pad for dry burnishing. Use where burnishing is required on a frequent basis for more time between re-coatings.

Joey® Specialty:
A super soft pad that is designed for soft, buffable finishes.

ULTRA HIGH SPEED BURNISHING PADS

BURNISHING PADS ~ Use on Machines Operating at 1,000-3,000 R.P.M.

Intended Use:

For use with floor finish where frequent (4+ times per week) to moderate (2-3 times per week) UHS burnishing is recommended.

Unless Otherwise Noted in Chart:

Floor pads have a 3.25" Center Hole and come 5 per case pack.
Round pads are available in smaller sizes upon request.

[A] GLIT® BLUE ICE® BURNISHING PAD EARTHTONE™

This pad is super soft for dry burnishing.

[B] GLIT® BEIGE BURNISHING PAD EARTHTONE™

This pad specially blends fibers, resin and a binder to produce a medium soft pad.

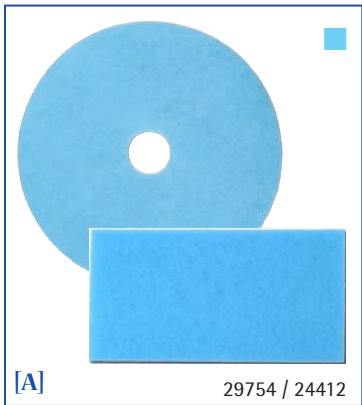

[C] GLIT® UHS AQUA BURNISHING PAD EARTHTONE™

This pad is a special blend of fibers, resin and a binder that produce a soft pad.

[D] GLIT® JOEY® SPECIALTY BURNISHING PAD EARTHTONE™

This pad specially blends fibers, resin and binder to produce a soft pad.



Size	Blue Ice® Item #	Case Weight	Case Cu. Ft.	Stock Item	Beige Item #	Case Weight	Case Cu. Ft.	Stock Item
17"	29772	2.60 lbs.	1.089		20283	2.20 lbs.	1.089	
18"	29773	2.72 lbs.	1.089		20284	2.70 lbs.	1.089	
19"	29774	2.87 lbs.	1.354	✓	20285	2.90 lbs.	1.354	
19.5"	29780	3.10 lbs.	1.354		---	---	---	
20"	29754	3.15 lbs.	1.354	✓	20286	3.13 lbs.	1.354	✓
21"	29755	3.30 lbs.	1.611		20287	3.30 lbs.	1.611	
22"	29775	3.50 lbs.	1.611		20288	4.00 lbs.	1.611	
23"	29776	4.20 lbs.	1.911		20289	4.20 lbs.	1.911	
24"	29756	4.40 lbs.	1.911		20290	4.40 lbs.	1.911	
*25"	*29777	2.50 lbs.	1.165		*20291	2.00 lbs.	1.165	
27"	29781	7.50 lbs.	2.608		23710	5.40 lbs.	2.060	
*27"	*29757	3.00 lbs.	1.165	✓	*20298	2.00 lbs.	1.165	
*27"	*23823	7.50 lbs.	2.608		---	---	---	
*27"	*29785	3.00 lbs.	1.165		*20309	2.00 lbs.	1.165	
28"	29787	7.80 lbs.	2.608		25228	6.00 lbs.	2.608	
*28"	*29779	3.20 lbs.	1.165		*20294	2.50 lbs.	1.165	
14" x 20"	24412	2.60 lbs.	1.338		---	---	---	
14" x 28"	24413	4.20 lbs.	2.586		---	---	---	
14" x 32"	24414	6.20 lbs.	1.707		---	---	---	
*14" x 32"	*24456	5.20 lbs.	1.707		---	---	---	

THESE PADS HAVE A 3.25" CENTER HOLE AND COME 2 PER CASE:

*29777 - 25" Blue Ice®, *20291 - 25" Beige, *20298 - 27" Beige, *29757 - 27" Blue Ice®, *29779 - 28" Blue Ice®, *20294 - 28" Beige

THESE PADS HAVE A .25" BOLT HOLE AND COME 5 PER CASE: *23823 - 27" Blue Ice®

THESE PADS HAVE A .25" BOLT HOLE AND COME 2 PER CASE: *29785 - 27" Blue Ice®, *20309 - 27" Beige

THESE PADS COME 10 PER CASE: *24456 - 14" x 32" Blue Ice®

Size	UHS Aqua Item #	Case Weight	Case Cu. Ft.	Stock Item	Joey® Item #	Case Weight	Case Cu. Ft.	Stock Item
17"	13517	2.50 lbs.	1.089		20478	2.20 lbs.	1.089	
18"	13518	2.65 lbs.	1.089		20479	2.45 lbs.	1.089	
19"	13519	2.80 lbs.	1.354		20480	2.75 lbs.	1.354	
20"	13520	3.00 lbs.	1.354	✓	20481	2.60 lbs.	1.354	
21"	13521	3.20 lbs.	1.611		20482	2.73 lbs.	1.611	
22"	13522	3.40 lbs.	1.611		20483	2.86 lbs.	1.611	
23"	13523	3.60 lbs.	1.911		20484	3.45 lbs.	1.911	
24"	13524	4.00 lbs.	1.911		20485	3.60 lbs.	1.911	
25"	---	---	---		*20486	2.00 lbs.	1.165	
27"	13557	7.00 lbs.	2.608	✓	20505	5.00 lbs.	2.608	
*27"	*13527	2.80 lbs.	1.165	✓	*20488	2.50 lbs.	1.165	
*27"	*23817	7.00 lbs.	2.608		---	---	---	
*27"	*13537	2.70 lbs.	1.165		*20504	2.50 lbs.	1.165	
28"	13538	4.50 lbs.	2.608		---	---	---	
*28"	*13528	2.80 lbs.	1.165		*20489	2.70 lbs.	1.165	

THESE PADS HAVE A 3.25" CENTER HOLE AND COME 2 PER CASE:

*20486 - 25" Joey®, *13527 - 27" UHS Aqua, *20488 - 27" Joey®, *29779 - 28" Blue Ice®, *20294 - 28" Beige, *13528 - 28" UHS Aqua, *20489 - 28" Joey®

THESE PADS HAVE A .25" BOLT HOLE AND COME 5 PER CASE: *23817 - 27" UHS Aqua

THESE PADS HAVE A .25" BOLT HOLE AND COME 2 PER CASE: *13537 - 27" UHS Aqua, *20504 - 27" Joey®

BURNISHING PADS ~ Use on Machines Operating at 1,000-3,000 R.P.M.

Intended Use:

Recommended for use with floor finish where moderate (2-3 times per week) to infrequent (1 time per week) UHS burnishing is required to produce a clean, shiny and safe floor.
 CHAMPAGNE: Infrequent to Moderate
 TAN: Infrequent to Moderate

Unless Otherwise Noted in Chart:

Floor pads have a 3.25" Center Hole and come 5 per Case Pack.
 Round pads are available in smaller sizes upon request.

[A] GLIT® CHAMPAGNE BURNISHING PAD EARTHTONE™

Rubberized resins combine with fine synthetic fibers to create a soft textured floor pad that can be used for dry UHS burnishing or buffing.

[B] GLIT® UHS TAN BURNISHING PAD EARTHTONE™

This pad reduces machine drag for all types of finishes.

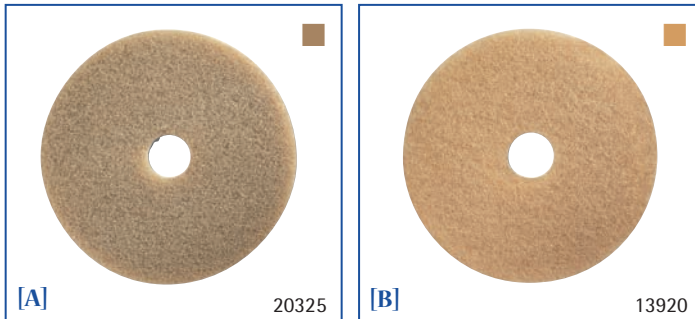

Size	Champagne Item #	Case Weight	Case Cu. Ft.	Stock Item	UHS Tan Item #	Case Weight	Case Cu. Ft.	Stock Item
17"	20322	2.24 lbs.	1.089		13917	2.20 lbs.	1.089	
18"	20323	2.60 lbs.	1.089		13918	2.80 lbs.	1.089	
19"	20324	3.00 lbs.	1.354	✓	13919	3.00 lbs.	1.354	
20"	20325	3.40 lbs.	1.354	✓	13920	3.28 lbs.	1.354	✓
21"	20326	3.65 lbs.	1.611		13921	3.50 lbs.	1.611	
22"	20327	3.87 lbs.	1.611		13922	3.75 lbs.	1.611	
23"	20328	4.50 lbs.	1.911		---	---	---	
24"	20329	4.80 lbs.	1.911		13924	4.00 lbs.	1.911	
*25"	*20330	2.80 lbs.	1.165		---	---	---	
27"	28547	5.50 lbs.	2.608		13957	6.25 lbs.	2.608	
*27"	23623	3.10 lbs.	1.165		*13927	3.00 lbs.	1.165	
*27"	*20348	3.20 lbs.	1.165		*15137	3.00 lbs.	1.165	
*28"	*20333	3.20 lbs.	1.165		*13928	3.50 lbs.	1.165	

THESE PADS HAVE A 3.25" CENTER HOLE AND COME 2 PER CASE:
 *20330 - 25" Champagne, *23623 - 25" Champagne, *13927 - 27" UHS Tan,
 *20333 - 28" Champagne, *13928 - 28" UHS Tan

THESE PADS HAVE A .25" BOLT HOLE AND COME 2 PER CASE:
 *20348 - 27" Champagne, *15137 - 27" UHS Tan

Glit/Microtron
DELIVERY
In Stock Products:
 Available to ship within two business days
Non-Stock Products:
 Available to ship within five business days

BURNISHING PADS ~ Use on Machines Operating at 1,000-3,000 R.P.M.

Intended Use:

Recommended for use with floor finish where moderate (2-3 times per week) to infrequent (1 time per week) UHS burnishing is required to produce a clean, shiny and safe floor.

JACKEROO LITE: Moderate

JACKEROO: Infrequent to Moderate

BUCKAROO: Infrequent

Unless Otherwise Noted in Chart:

Floor pads have a 3.25" Center Hole and come 5 per Case Pack.
Round pads are available in smaller sizes upon request.

[A] GLIT® JACKEROO® LITE NATURAL HAIR PAD



This pad is a lighter mix of natural hair which quickly and easily produces an exceptional gloss.

[B] GLIT® JACKEROO® NATURAL HAIR PAD



This pad is a blend of natural hair and synthetic fibers with the lubrication effect of a hair pad and rubberized binder.

[C] GLIT® BUCKAROO® NATURAL HAIR PAD



This pad is made of natural hair with a hard and aggressive binder.



Size	Jackeroo® Lite Item #	Case Weight	Case Cu. Ft.	Stock Item	Jackeroo® Item #	Case Weight	Case Cu. Ft.	Stock Item	Buckaroo® Item #	Case Weight	Case Cu. Ft.	Stock Item
17"	20439	2.08 lbs.	1.089		20400	2.00 lbs.	1.089	✓	20361	2.40 lbs.	1.089	✓
18"	23421	2.60 lbs.	1.089		21813	2.80 lbs.	1.089		20362	2.84 lbs.	1.089	
19"	20441	2.96 lbs.	1.354		20402	2.84 lbs.	1.354	✓	20363	3.30 lbs.	1.354	✓
20"	20442	3.12 lbs.	1.354	✓	20403	3.00 lbs.	1.354	✓	20364	3.56 lbs.	1.354	✓
21"	20443	3.04 lbs.	1.471		20404	3.25 lbs.	1.611	✓	20365	3.84 lbs.	1.611	
22"	23336	4.00 lbs.	1.611		20405	3.60 lbs.	1.611		20366	4.48 lbs.	1.611	
23"	26034	4.25 lbs.	1.911		20406	4.25 lbs.	1.911		20367	4.65 lbs.	1.911	
24"	23330	4.40 lbs.	1.911		20407	4.20 lbs.	1.911		20368	4.80 lbs.	1.911	
*25"	*24102	3.50 lbs.	1.165		*20408	2.78 lbs.	1.165		*20369	3.10 lbs.	1.165	
27"	23671	5.70 lbs.	2.608	✓	23840	7.25 lbs.	2.608		28548	6.00 lbs.	2.608	✓
*27"	*23626	4.00 lbs.	1.165	✓	*23625	3.00 lbs.	1.165		*23624	7.50 lbs.	2.608	✓
*27"	*20466	4.87 lbs.	2.429		---	---	---		*20386	3.20 lbs.	1.165	
*27"	*20465	2.80 lbs.	1.165		*20426	3.00 lbs.	1.165		*20387	3.00 lbs.	1.165	
*28"	*20450	3.50 lbs.	1.165		*20411	3.10 lbs.	1.165		*20372	3.50 lbs.	1.165	

THESE PADS HAVE A 3.25" CENTER HOLE AND COME 2 PER CASE:

*24102 - 25" Jackeroo® Lite, *23626 - 27" Jackeroo® Lite, *20450 - 28" Jackeroo® Lite, *20408 - 25" Jackeroo®, *23625 - 27" Jackeroo®, *20411 - 28" Jackeroo®, *20369 - 25" Buckaroo®, *23624 - 27" Buckaroo®, *20372 - 28" Buckaroo®

THESE PADS HAVE A .25" BOLT HOLE AND COME 5 PER CASE:

*20466 - 27" Jackeroo® Lite, *20386 - 27" Buckaroo®

THESE PADS HAVE A .25" BOLT HOLE AND COME 2 PER CASE:

*20465 - 27" Jackeroo® Lite, *20426 - 27" Jackeroo®, *20387 - 27" Buckaroo®



Glit/Microtron
DELIVERY
In Stock Products:
Available to ship within
two business days
Non-Stock Products:
Available to ship within
five business days

BURNISHING PADS ~ Use on Machines Operating at 1,000-3,000 R.P.M.

[A] GLIT® COCOPAD® EARTHTONE™

This is a naturally lubricating fiber pad for UHS burnishing. Made with coconut fibers that are both organic and biodegradable.

Size	Item #	Case Weight	Case Cu. Ft.	Stock Item	Size	Item #	Case Weight	Case Cu. Ft.	Stock Item
17"	24005	2.58 lbs.	1.089		24"	24012	4.27 lbs.	1.911	
18"	24006	2.73 lbs.	1.089		*26"	*24014	1.90 lbs.	1.175	
19"	24007	2.88 lbs.	1.354		*27"	*24016	2.80 lbs.	1.165	
20"	24008	3.00 lbs.	1.354	✓	*27"	*24015	2.80 lbs.	1.165	
21"	24009	3.15 lbs.	1.611		*28"	*24017	2.90 lbs.	1.165	
22"	24010	3.50 lbs.	1.611		*28"	*24018	2.90 lbs.	1.165	
23"	24011	4.10 lbs.	1.911						



THESE PADS HAVE A 3.25" CENTER HOLE AND COME 2 PER CASE:
 *24014 - 26" CoCoPad®, *24016 - 27" CoCoPad®, *24017 - 28" CoCoPad®

THESE PADS HAVE A .25" BOLT HOLE AND COME 2 PER CASE:
 *24015 - 27" CoCoPad®, *24018 - 28" CoCoPad®

BURNISHING PADS ~ Use on Machines Operating at 175-3,000 R.P.M.

Intended Use:
 For use with floor finish where moderate (2-3 times per week) to infrequent (1 time per week) UHS burnishing is required.

Unless Otherwise Noted in Chart:
 Floor pads have a 3.25" Center Hole and come 5 per Case Pack.
 Round pads are available in smaller sizes upon request.

[B] GLIT® PEACH PAD EARTHTONE™

This mildly aggressive pad is designed for UHS burnishing as well as spray buffing applications. This pad can be used on machines operating up to 1,500 R.P.M.

[C] GLIT® 100-D NEUTRAL POLY THERMAL PAD EARTHTONE™

This pad blends fibers, resins and binders to produce a medium-soft pad.

Size	Peach Item #	Case Weight	Case Cu. Ft.	Stock Item	100-D Item #	Case Weight	Case Cu. Ft.	Stock Item
17"	20517	2.20 lbs.	1.089		44817	2.54 lbs.	1.089	
18"	20518	2.52 lbs.	1.089		44818	2.70 lbs.	1.089	
19"	20519	2.85 lbs.	1.354		44819	2.80 lbs.	1.354	
20"	20520	3.00 lbs.	1.354	✓	44820	3.11 lbs.	1.354	
21"	20521	3.15 lbs.	1.611		44821	3.68 lbs.	1.611	
22"	20522	3.30 lbs.	1.611		44822	5.70 lbs.	1.611	
24"	20524	3.60 lbs.	1.911		44824	5.15 lbs.	1.911	
27"	---	---	---		44829	8.00 lbs.	2.608	
*27"	*23628	2.50 lbs.	1.600		*44827	2.50 lbs.	1.165	
*27"	*20543	2.24 lbs.	1.165		---	---	---	
28"	20528	5.80 lbs.	2.608		*44828	2.55 lbs.	1.165	

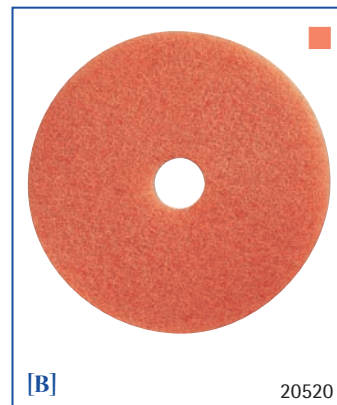

Glit/Microtron
DELIVERY
In Stock Products:
 Available to ship within two business days
Non-Stock Products:
 Available to ship within five business days

THESE PADS HAVE A 3.25" CENTER HOLE AND COME 2 PER CASE:
 *23628 - 27" Peach, *44827 - 27" 100-D Neutral Poly Thermal, *44828 - 28" 100-D Neutral Poly Thermal
 THESE PADS HAVE A .25" BOLT HOLE AND COME 2 PER CASE: *20543 - 27" Peach

SPECIALTY FLOOR PADS

WOOD FLOOR PADS ~ Use on Machines Operating at 175-350 R.P.M.

Not Intended for Use:

On linoleum or marble. Always follow proper floor stripping guidelines.

General Information:

Floor pads have a 3.25" Center Hole and come 10 per case pack.
Round pads are available in smaller sizes upon request.

GLIT® MAROON WOOD SURFACING PAD EARTHTONE™

Designed for wood floor cleaning with minimal coating removal.

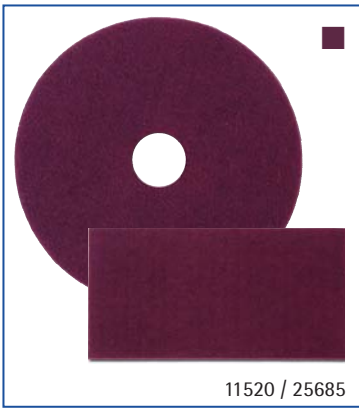

Size	Item #	Case Weight	Case Cu. Ft.	Stock Item	Size	Item #	Case Weight	Case Cu. Ft.	Stock Item
13"	11513	2.20 lbs.	0.699		20"	11520	5.65 lbs.	1.354	
14"	11514	2.70 lbs.	0.699		21"	11521	5.80 lbs.	1.611	
15"	11515	3.20 lbs.	0.853		24"	11524	6.60 lbs.	1.911	
16"	11516	3.60 lbs.	0.853		12" x 18"	*25056	4.00 lbs.	1.120	
17"	11517	4.80 lbs.	1.089		14" x 20"	25685	3.00 lbs.	2.630	
18"	11518	5.10 lbs.	1.089		14" x 28"	25686	3.50 lbs.	2.630	
19"	11519	5.40 lbs.	1.354		14" x 32"	*25687	7.75 lbs.	1.707	

THESE PADS COME 10 PER CASE: *25056 - 12" x 18", *25687 - 14" x 32"



UTILITY PADS/HOLDERS & STRIPPING BOOTS

An integrated system of distinct utility pads and holders. Stripping Boots provide safety and protection.

[A] KLEENFAST® THICKLINE UTILITY PADS EARTHTONE™

LIGHT-DUTY - WHITE

A light-duty pad for cleaning delicate surfaces and light cleanup on sinks, ceramic tile, windows, tubs and toilets.

MEDIUM-DUTY - BLUE

Use to clean baseboards, swimming pool walls and for removing scuff marks on floors.

HEAVY-DUTY - BROWN

For heavily soiled traffic areas such as halls, stairs, around stoves and fryers. Easily removes old finish and wax build-up.

HEAVY-DUTY - BLACK

Brand	Item #	Size	Color	Case Pack	Case Weight	Case Cubic Ft.	Stock Item
Glit	20968	4 1/2" x 10"	White	4/5	2.20 lbs.	0.669	✓
Glit	20967	4 1/2" x 10"	Blue	4/5	2.80 lbs.	0.669	✓
Glit	20969	4 1/2" x 10"	Brown	4/5	2.40 lbs.	0.669	✓
Glit	22508	4 1/2" x 10"	Black	4/5	3.80 lbs.	0.669	✓



[A] 20968 / 20967 / 20969 / 22508

[B] KLEENFAST® THICKLINE UTILITY PAD KITS EARTHTONE™

Kits contain one of three styles of holders, along with one Brown and one White Pad.

Brand	Item #	Description	Case Pack	Case Weight	Case Cubic Ft.	Stock Item
Glit	20972	Universal Swivel Holder Kit	4 Kits / cs.	4.20 lbs.	0.669	
Glit	23217	Handblock Pad Holder Kit	4 Kits / cs.	4.00 lbs.	0.669	
Glit	20983	Mini Handblock Holder Kit	4 Kits / cs.	4.00 lbs.	0.669	



[B] 20972

[C] SAFIRE® 66 UTILITY PADS EARTHTONE™

Strip heavy wax build-up where machines can't reach, such as baseboards and corners.

[C] SAFIRE® 66 UTILITY PAD KITS EARTHTONE™

Kits contain one of three styles of holders, along with two Safire® Pads.

[D] EMERALD II UTILITY PADS - HEAVY-DUTY EARTHTONE™

Strip heavy wax build-up where machines can't reach, such as baseboards and corners.

[D] EMERALD II UTILITY PAD KITS EARTHTONE™

Kits contain one of three styles of holders, along with two Emerald II Pads.

[E] KLEENFAST® PAD HOLDERS

Brand	Item #	Description	Case Pack	Case Weight	Case Cubic Ft.	Stock Item
Glit	23554	Blue 3 1/2" x 6" Pads	4 / 10	3.00 lbs.	1.279	
Glit	23553	Blue 4 1/2" x 10" Pads	4 / 10	5.00 lbs.	1.279	
Glit	26067	Universal Swivel Holder Kit	4 Kits / cs.	5.00 lbs.	0.669	
Glit	26068	Handblock Pad Holder Kit	4 Kits / cs.	5.00 lbs.	0.669	
Glit	20985	Green 3 1/2" x 6" Pads	4 / 10	3.00 lbs.	1.279	
Glit	20976	Green 4 1/2" x 10" Pads	4 / 10	6.00 lbs.	1.279	
Glit	20978	Universal Swivel Holder Kit	4 Kits / cs.	5.50 lbs.	0.669	
Glit	20979	Handblock Pad Holder Kit	4 Kits / cs.	5.50 lbs.	0.669	
Glit	20986	Mini Handblock Holder Kit	4 Kits / cs.	5.50 lbs.	0.669	
Glit	20931	Swivel Holder Universal	12 bulk	5.00 lbs.	0.669	
Glit	20975	Handblock Pad Holder	12 bulk	5.00 lbs.	0.669	
Glit	20984	Mini Handblock Holder	12 bulk	5.00 lbs.	0.669	

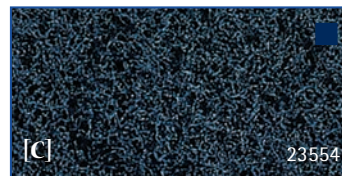

[C] 23554

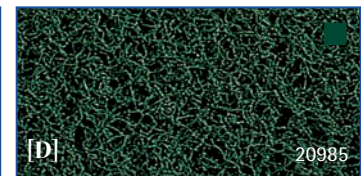

[D] 20985



[E] 20931



[E] 20975



[E] 20984

Glit/Microtron
DELIVERY
In Stock Products:
Available to ship within
two business days
Non-Stock Products:
Available to ship within
five business days

UTILITY PADS / HOLDERS

[A] SWIVEL HAND PAD HOLDER



4" x 9" plastic holder with swivel action for easy scrubbing. Hooks hold pad in place. Velcro® bottom for easy pad attachment. Tapered handle sold separately.

Brand	Item #	Size	Swivel Length	Case Pack	Case Weight	Case Cu. Ft.	Stock Item
Wilco	J203000	4" x 9"	5"	4	3.00 lbs.	0.920	✓



Accepts tapered handles only. Found on page 51

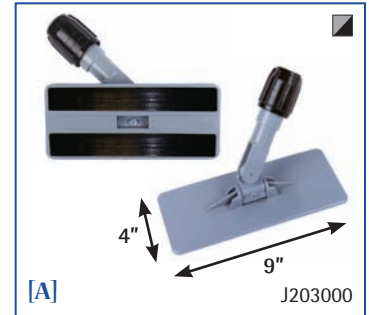

STRIPPING BOOTS

[B] STRIPPING BOOTS

These Stripping Boots reduce the likelihood of a slip and fall injury with the added benefit of keeping your footwear dry and protected from harsh chemicals.

Brand	Item #	Description	Size	Case Pack	Case Weight	Case Cu. Ft.	Stock Item
Glit	23411	Kit: 1-Pair Protective Shoes & 2-Pair Replacement Soles	Small (6-8)	1 Kit	1.80 lbs.	0.386	
Glit	23412	Kit: 1-Pair Protective Shoes & 2-Pair Replacement Soles	Medium (8-9 1/2")	1 Kit	1.80 lbs.	0.386	
Glit	23413	Kit: 1-Pair Protective Shoes & 2-Pair Replacement Soles	Large (9 1/2"-11)	1 Kit	2.20 lbs.	0.386	
Glit	23414	Kit: 1-Pair Protective Shoes & 2-Pair Replacement Soles	X-Large (11-14)	1 Kit	2.40 lbs.	0.386	
Glit	23467	Kit: 3-Pair Replacement Soles	Small	1 Kit	1.00 lbs.	0.386	
Glit	23468	Kit: 3-Pair Replacement Soles	Medium	1 Kit	1.00 lbs.	0.386	
Glit	23469	Kit: 3-Pair Replacement Soles	Large	1 Kit	1.20 lbs.	0.386	
Glit	23470	Kit: 3-Pair Replacement Soles	X-Large	1 Kit	1.20 lbs.	0.386	



STONE CARE FLOOR PADS & CHEMICALS

Glit's Cyclone™ product line is the latest example of our long-standing tradition of bringing new and innovative products to the market. Cyclone™ pads repair scratches, restore the floor's gloss and when used regularly, provide a simple, ongoing maintenance solution.

Cyclone™ offers a complete line of easy-to-use maintenance pads and chemicals that allow you to choose the best option for your customers! The Cyclone™ line offers a choice in performance technology. Our Cyclone-D™ line features diamond abrasives and our Cyclone™ line features a proprietary blend of cost-effective abrasives. Pads are made with 100% recycled fiber - all Cyclone™ pads are environmentally friendly!

STONE CARE FLOOR PADS

CYCLONE-D™ EARTHSTONE™

For use on concrete, granite, limestone, marble, terrazzo and travertine. The state-of-the-art technology that produces these pads yields better results with less labor. Even on the hardest surfaces, Cyclone-D™ can be used without heavy-duty grinding equipment and harsh chemicals; and can be carried out daily with your existing custodial staff.

STONE CARE FLOOR PADS



CYCLONE-D™ SERIES EARTHTONE™

Available in five levels of abrasiveness. Pads are available in a variety of shapes and sizes so that they can be easily incorporated with any floor equipment or hand tools. Cyclone-D™ pads contain wear indicators, making it easy to determine when to replace them. They can be used wet or dry.

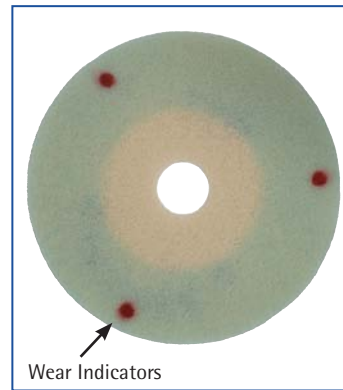
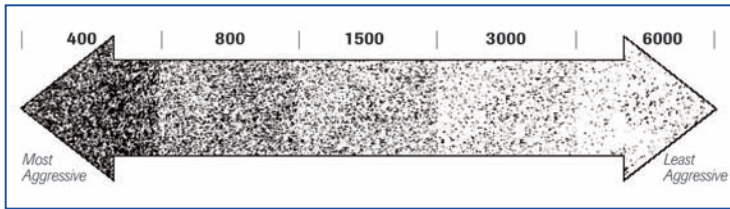

Brand	400 Grit Item #	Stock Item	800 Grit Item #	Stock Item	1,500 Grit Item #	Stock Item	3,000 Grit Item #	Stock Item	6,000 Grit Item #	Stock Item	Size	Case Pack	Case Weight	Case Cubic Ft.
Glit	10605		11005		13005		16005		19005		5"	10	1.00 lbs.	0.400
Glit	10608		11008		13008		16008		19008		8"	2	0.85 lbs.	0.400
Glit	10610		11010		13010		16010		19010		10"	2	0.95 lbs.	0.400
Glit	10612		11012	✓	13012	✓	16012	✓	19012		12"	2	1.00 lbs.	0.400
Glit	10613		11013	✓	13013	✓	16013	✓	19013	✓	13"	2	1.00 lbs.	0.400
Glit	10614		11014	✓	13014	✓	16014	✓	19014		14"	2	1.10 lbs.	0.400
Glit	10615		11115		13115		16115		19115		15"	2	1.10 lbs.	0.500
Glit	10616		11016		13016		16016		19016		16"	2	1.17 lbs.	0.500
Glit	10617	✓	11017	✓	13017	✓	16017	✓	19017	✓	17"	2	1.20 lbs.	0.500
Glit	10618		11018	✓	13018	✓	16018	✓	19018		18"	2	1.26 lbs.	0.620
Glit	10619		11019	✓	13019	✓	16019	✓	19019		19"	2	1.41 lbs.	0.610
Glit	10620	✓	11020	✓	13020	✓	16020	✓	19020	✓	20"	2	2.00 lbs.	0.750
Glit	10621		11021		13021		16021		19021		21"	2	2.10 lbs.	1.090
Glit	10624		11024		13024		16024		19024		24"	2	2.03 lbs.	1.090
Glit	10627	✓	11027	✓	13027	✓	16027	✓	19027	✓	27"	2	3.00 lbs.	1.180
Glit	10602		10420	✓	13420	✓	16420	✓	19420		14" x 20"	2	1.19 lbs.	0.430
Glit	10628		10428	✓	13428	✓	16428	✓	19428		14" x 28"	2	2.00 lbs.	0.760
Glit	10632		11032	✓	13032	✓	16032	✓	19032		14" x 32"	2	2.20 lbs.	0.860

DELIVERY INFORMATION
In Stock Products: Available to ship within **two** business days
Non-Stock Products: Available to ship within **fifteen** business days

STONE CARE FLOOR PADS



CYCLONE™ STONE CARE FLOOR PADS EARTHSTONE™

Made with proprietary diamond alternative technology, these pads provide an economical solution to daily stone floor care. With five to ten times the life of regular aluminum oxide, our proprietary blend has now become, as an abrasive, a much less expensive substitute for industrial diamonds in numerous abrasive uses. Cyclone™ pads cut quickly without overheating or burning the material being ground, with high heat resistance and good mechanical strength.

A three-pad-system; color-coded for easy identification:

WHITE CYCLONE™ FLOOR PADS

Our most aggressive Cyclone™ pad. Use for deep cleaning and scratch removal. Prepares the surface for micro-polishing.

YELLOW CYCLONE™ FLOOR PADS

Micro polishes the floor to improve gloss and remove light scratches that distort gloss.

GREEN CYCLONE™ FLOOR PADS

Use daily for a clean, safe and shiny floor.

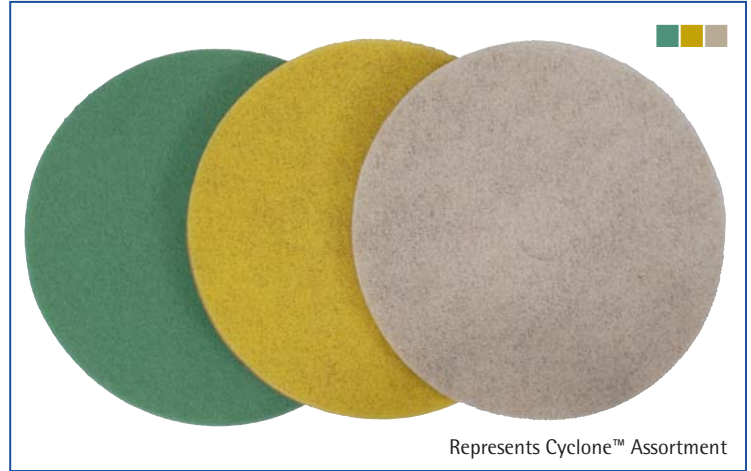

Brand	White Item #	Stock Item	Yellow Item #	Stock Item	Size	Case Pack	Case Weight	Case Cubic Ft.	Brand	Green Item #	Stock Item	Size	Case Pack	Case Weight	Case Cubic Ft.
Glit	25725		25726		13"	5	2.57 lbs.	0.690	Glit	25727		13"	5	2.21 lbs.	0.690
Glit	25728		25729		14"	5	2.77 lbs.	0.690	Glit	25730		14"	5	2.35 lbs.	0.690
Glit	25757		25758		15"	5	2.87 lbs.	0.890	Glit	25759		15"	5	2.46 lbs.	0.890
Glit	25731		25732		16"	5	3.73 lbs.	0.890	Glit	25733		16"	5	3.16 lbs.	0.890
Glit	35734		35735		17"	5	4.04 lbs.	1.120	Glit	35736		17"	5	3.42 lbs.	1.120
Glit	25761		25762		18"	5	4.16 lbs.	1.120	Glit	25763		18"	5	3.52 lbs.	1.120
Glit	25773		25774		19"	5	4.54 lbs.	1.370	Glit	25775		19"	5	3.83 lbs.	1.370
Glit	25737		25738		20"	5	4.72 lbs.	1.370	Glit	25739		20"	5	3.98 lbs.	1.370
Glit	25764		25765		21"	5	6.31 lbs.	1.650	Glit	25766		21"	5	5.30 lbs.	1.650
Glit	25740		25741		27"	2	3.78 lbs.	1.16	Glit	25742		27"	2	3.21 lbs.	1.160
Glit	25743		25744		14" x 18"	5	2.65 lbs.	1.089	Glit	25745		14" x 18"	5	2.40 lbs.	1.089
Glit	25746		25747		12" x 20"	5	5.24 lbs.	1.340	Glit	25748		12" x 20"	5	4.41 lbs.	1.340
Glit	25749		25750		14" x 28"	5	5.40 lbs.	2.608	Glit	25751		14" x 28"	5	4.89 lbs.	2.608
Glit	25752		25753		14" x 32"	5	5.70 lbs.	1.707	Glit	25754		14" x 32"	5	5.10 lbs.	1.707



STONE CARE CHEMICALS

The Cyclone-D™ line includes three chemicals which were specially designed to further enhance daily maintenance results when used with Cyclone-D™ floor pads.

[A] CYCLONE-D™ CLEANER / CONDITIONER

A high dilution product for use on natural stone, terrazzo and polished concrete surfaces. Specially formulated to clean as well as enhance the life and performance of the Cyclone™ pad. It is rinse free and, with continued use, will aid in the appearance of the surface while increasing its resistance to soiling.

[B] CYCLONE-D™ CONCRETE CLEANER

Thoroughly cleans polished concrete while also enhancing its appearance. Proprietary ingredients encapsulate and hold soil in suspension for complete removal. Concrete cleaner is film and rinse free.

[C] CYCLONE-D™ GLOSS BOOST

A safe, simple, non-crystallization method to freshen the appearance of limestone, marble, travertine and cement based terrazzo that has been previously polished.



[A] CD101 / CD116



[B] CD102



[C] CD103

Brand	Item #	Size	Case Pack	Case Weight	Case Cubic Ft.	Stock Item
Glit	CD101	1 gallon	4/1	34.50 lbs.	0.690	✓
Glit	CD116	16 oz.	6/16	6.50 lbs.	1.000	✓
Glit	CD102	12 oz.	12/12	9.00 lbs.	0.690	✓
Glit	CD103	16 oz.	16/16	6.00 lbs.	0.690	✓

SANDSCREENS & PAD DRIVERS

More is what you will get from our silicon carbide coated sandscreens. Our innovative, state-of-the-art process applies the grain and binder to our screens uniformly for unsurpassed performance.

[D] SANDSCREEN PAD DRIVERS **EARTHSTONE™**

Say goodbye to "screen sling." Our best in class Pad Driver holds tight when others let go.



[D] 23754 / 24432

Brand	Item #	Size	Case Pack	Case Weight	Case Cu. Ft.	Stock Item	Brand	Item #	Size	Case Pack	Case Weight	Case Cu. Ft.	Stock Item
Glit	23784	12"	2	0.50 lbs.	0.115		Glit	23754	20"	2	0.80 lbs.	0.176	
Glit	23785	13"	2	0.52 lbs.	0.115		Glit	23780	21"	2	0.84 lbs.	0.290	
Glit	23786	14"	2	0.54 lbs.	0.115		Glit	23781	22"	2	0.90 lbs.	0.290	
Glit	23759	15"	2	0.60 lbs.	0.115		Glit	23782	23"	2	0.95 lbs.	0.347	
Glit	23760	16"	2	0.64 lbs.	0.115		Glit	23783	24"	2	1.00 lbs.	0.347	
Glit	23761	17"	2	0.68 lbs.	0.145		Glit	24432	14" x 20"	2	0.60 lbs.	0.178	
Glit	23787	18"	2	0.72 lbs.	0.145		Glit	24433	14" x 28"	2	0.85 lbs.	0.176	
Glit	23779	19"	2	0.76 lbs.	0.176		Glit	24434	*14" x 32"	2	1.00 lbs.	0.205	





SANDSCREENS & PAD DRIVERS

SANDSCREENS

These screens deliver 25% more cutting action and last 30% longer than before. Available in seven grits and disc sizes from 12 to 24 inches.

Brand	Item #	Size	Grit	Case Pack	Case Weight	Case Cubic Ft.	Stock Item	Brand	Item #	Size	Grit	Case Pack	Case Weight	Case Cubic Ft.	Stock Item
Glit	42149	12"	60	10	2.45 lbs.	0.116		Glit	42143	18"	80	10	3.16 lbs.	0.190	
Glit	42162	12"	100	10	1.86 lbs.	0.116		Glit	42006	18"	100	10	2.80 lbs.	0.190	
Glit	42166	12"	120	10	1.58 lbs.	0.116		Glit	42104	18"	120	10	2.60 lbs.	0.234	
Glit	42173	12"	150	10	1.50 lbs.	0.116		Glit	42023	18"	150	10	2.50 lbs.	0.234	
Glit	42180	12"	180	10	1.38 lbs.	0.116		Glit	42039	18"	220	10	2.20 lbs.	0.234	
Glit	42150	13"	60	10	2.70 lbs.	0.116		Glit	42093	19"	60	10	4.00 lbs.	0.234	
Glit	42157	13"	80	10	1.90 lbs.	0.116		Glit	42144	19"	80	10	4.20 lbs.	0.234	
Glit	42001	13"	100	10	1.75 lbs.	0.116		Glit	42045	19"	100	10	3.80 lbs.	0.234	
Glit	42167	13"	120	10	1.60 lbs.	0.116		Glit	42011	19"	120	10	3.55 lbs.	0.234	
Glit	42174	13"	150	10	1.45 lbs.	0.116		Glit	42007	19"	150	10	3.30 lbs.	0.234	
Glit	42181	13"	180	10	1.35 lbs.	0.116		Glit	42184	19"	180	10	3.00 lbs.	0.234	
Glit	42191	13"	220	10	1.20 lbs.	0.116		Glit	42193	19"	220	10	2.60 lbs.	0.234	
Glit	42151	14"	60	10	2.80 lbs.	0.116		Glit	42094	20"	60	10	4.67 lbs.	0.182	
Glit	42158	14"	80	10	2.30 lbs.	0.116		Glit	42145	20"	80	10	3.93 lbs.	0.182	✓
Glit	42163	14"	100	10	2.00 lbs.	0.116		Glit	42012	20"	100	10	3.70 lbs.	0.182	✓
Glit	42168	14"	120	10	1.90 lbs.	0.116		Glit	42066	20"	120	10	3.60 lbs.	0.182	✓
Glit	42175	14"	150	10	1.80 lbs.	0.116		Glit	42199	20"	150	10	3.40 lbs.	0.182	
Glit	42089	15"	60	10	2.80 lbs.	0.116		Glit	42185	20"	180	10	3.15 lbs.	0.182	
Glit	42098	15"	80	10	2.60 lbs.	0.116		Glit	42194	20"	220	10	2.90 lbs.	0.182	
Glit	41991	15"	100	10	2.40 lbs.	0.116		Glit	42152	21"	60	10	4.80 lbs.	0.286	
Glit	41992	15"	120	10	2.20 lbs.	0.116		Glit	42015	21"	80	10	4.10 lbs.	0.290	
Glit	41993	15"	150	10	2.16 lbs.	0.116		Glit	42027	21"	100	10	3.80 lbs.	0.290	
Glit	41994	15"	180	10	1.90 lbs.	0.116		Glit	42169	21"	120	10	3.70 lbs.	0.290	
Glit	41995	15"	220	10	1.60 lbs.	0.116		Glit	42176	21"	150	10	3.50 lbs.	0.290	
Glit	42090	16"	60	10	3.50 lbs.	0.116		Glit	42186	21"	180	10	3.30 lbs.	0.290	
Glit	42099	16"	80	10	2.55 lbs.	0.116		Glit	42195	21"	220	10	3.10 lbs.	0.290	
Glit	42003	16"	100	10	2.50 lbs.	0.116		Glit	42159	22"	80	10	5.60 lbs.	0.290	
Glit	42004	16"	120	10	2.50 lbs.	0.116		Glit	42033	22"	100	10	5.12 lbs.	0.290	
Glit	42055	16"	150	10	2.40 lbs.	0.116		Glit	42170	22"	120	10	4.80 lbs.	0.290	
Glit	42000	16"	180	10	2.40 lbs.	0.116		Glit	42177	22"	150	10	4.20 lbs.	0.290	
Glit	42046	16"	220	10	2.00 lbs.	0.116		Glit	42187	22"	180	10	3.90 lbs.	0.290	
Glit	42091	17"	60	10	3.35 lbs.	0.190		Glit	42154	23"	60	10	7.40 lbs.	0.230	
Glit	42100	17"	80	10	2.80 lbs.	0.190		Glit	42160	23"	80	10	6.20 lbs.	0.230	
Glit	42044	17"	100	10	2.60 lbs.	0.190		Glit	42164	23"	100	10	5.30 lbs.	0.230	
Glit	43179	17"	120	10	2.40 lbs.	0.190		Glit	42171	23"	120	10	4.73 lbs.	0.230	
Glit	41133	17"	150	10	2.30 lbs.	0.190		Glit	42161	24"	80	10	5.30 lbs.	0.344	
Glit	41134	17"	180	10	2.20 lbs.	0.190		Glit	42165	24"	100	10	4.80 lbs.	0.344	
Glit	42043	17"	220	10	2.00 lbs.	0.190		Glit	42172	24"	120	10	4.40 lbs.	0.344	
Glit	42092	18"	60	10	3.50 lbs.	0.190		Glit	42189	24"	180	10	3.80 lbs.	0.344	

SANDSCREENS & PAD DRIVERS

Brand	Item #	Size	Grit	Case Pack	Case Weight	Case Cubic Ft.	Stock Item
Glit	24435	14" x 20"	60	10	4.20 lbs.	0.178	
Glit	24436	14" x 20"	80	10	3.60 lbs.	0.178	
Glit	24437	14" x 20"	100	10	3.40 lbs.	0.178	
Glit	24438	14" x 20"	120	10	3.10 lbs.	0.178	
Glit	24439	14" x 20"	150	10	2.90 lbs.	0.178	
Glit	24440	14" x 28"	60	10	5.40 lbs.	0.176	
Glit	24441	14" x 28"	80	10	4.30 lbs.	0.176	
Glit	24442	14" x 28"	100	10	3.90 lbs.	0.176	
Glit	24443	14" x 28"	120	10	3.50 lbs.	0.176	
Glit	24444	14" x 28"	150	10	3.30 lbs.	0.176	
Glit	24445	14" x 32"	60	10	8.20 lbs.	0.273	
Glit	24446	14" x 32"	80	10	6.40 lbs.	0.273	
Glit	24447	14" x 32"	100	10	5.90 lbs.	0.273	
Glit	24448	14" x 32"	120	10	5.40 lbs.	0.273	
Glit	24449	14" x 32"	150	10	5.10 lbs.	0.273	

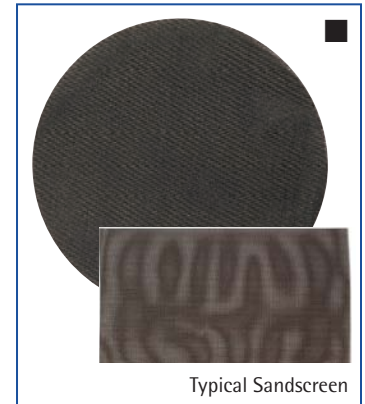

CARPET BONNETS & MICROFIBER FLOOR PADS

Our carpet bonnets offer a clean and effective method for routine carpet cleaning. Choose high or low pile, absorbent or aggressive.

[A] KING™ BONNET

This high profile bonnet has looped nylon/poly yarn for high absorption and durability.

[B] KING COTTON® BONNET

Thick profile pad with looped-end, small diameter cotton yarn provides maximum absorption.

[C] QUEEN™ BONNET

Medium profile pad is constructed of aggressive, yet absorbent, blended looped-end yarn for extra durability. Ideal for medium to thick carpet. Aggressive scrubbing strips.

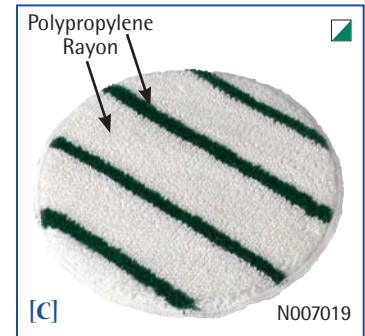
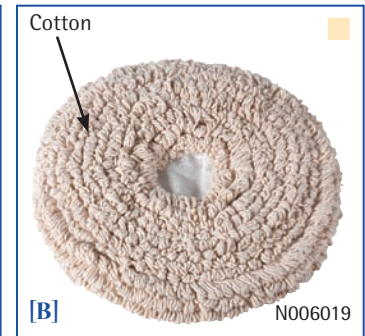
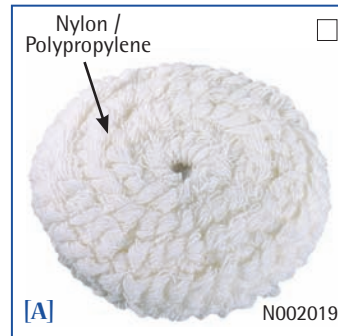

Brand	Item #	Item	Size	Case Pack	Case Weight	Case Cubic Ft.	Stock Item
Wilco	N002017	King™ Bonnet	17"	6	12.00 lbs.	2.192	✓
Wilco	N002019	King™ Bonnet	19"	6	14.00 lbs.	2.192	✓
Wilco	N002021	King™ Bonnet	21"	6	16.00 lbs.	2.192	✓
Wilco	N006017	King Cotton® Bonnet	17"	6	12.00 lbs.	2.192	✓
Wilco	N006019	King Cotton® Bonnet	19"	6	14.00 lbs.	2.192	✓
Wilco	N006021	King Cotton® Bonnet	21"	6	16.00 lbs.	2.192	✓
Wilco	N007017	Queen™ Bonnet	17"	6	8.00 lbs.	1.689	✓
Wilco	N007019	Queen™ Bonnet	19"	6	10.00 lbs.	1.689	✓
Wilco	N007021	Queen™ Bonnet	21"	6	11.00 lbs.	1.689	✓



CARPET BONNETS

[A] PRINCE™ BONNET

This low profile pad is for maximum agitation and tough jobs. Constructed of looped-end, blended yarn, providing thorough cleaning and stable machine operation.

[B] QUEEN™ MITT

Great tool for cleaning spots, stairs and other small areas of carpet. Looped-end yarn absorbs cleaning solution while the non-damaging cleaning strips agitate the fibers for effective cleaning. Use with any common carpet cleaning solution. Highly launderable.

Brand	Item #	Item	Size	Case Pack	Case Weight	Case Cubic Ft.	Stock Item
Wilco	N009017	Prince™ Bonnet	17"	6	12.00 lbs.	1.701	✓
Wilco	N009019	Prince™ Bonnet	19"	6	14.00 lbs.	1.701	✓
Wilco	N009021	Prince™ Bonnet	21"	6	16.00 lbs.	1.701	✓
Wilco	N010021	Queen™ Mitt	21"	6	16.00 lbs.	2.192	✓
Wilco	N012008	Queen™ Mitt	8"	6	4.00 lbs.	0.375	✓

MICROFIBER FLOOR PADS

[C] DEEP SCRUB PAD

Use dry or wet on multiple floor surfaces to loosen deeply embedded soils. Use with machines operating at 175-350 R.P.M. Machine washable.

[D] DRY POLISH PAD

Use on any uneven or smooth surface with or without a buffable finish (marble, slate and resilient tile for example). Can also be used on propane machines operating at 1,000-3,000 R.P.M. Machine washable.

Brand	Item #	Item	Size	Case Pack	Case Weight	Case Cubic Ft.	Stock Item
Glit	24151	Deep Scrub Pad	13"	1	0.60 lbs.	0.115	
Glit	24152	Deep Scrub Pad	13"	5	1.60 lbs.	0.669	
Glit	24154	Deep Scrub Pad	14"	1	1.00 lbs.	0.115	
Glit	24155	Deep Scrub Pad	14"	5	2.00 lbs.	0.669	
Glit	23442	Deep Scrub Pad	17"	1	0.93 lbs.	0.145	
Glit	24156	Deep Scrub Pad	17"	5	2.40 lbs.	1.089	
Glit	23443	Deep Scrub Pad	19"	1	1.00 lbs.	0.178	
Glit	24157	Deep Scrub Pad	19"	5	3.20 lbs.	1.354	
Glit	23444	Deep Scrub Pad	20"	1	1.20 lbs.	0.178	
Glit	24158	Deep Scrub Pad	20"	5	3.60 lbs.	1.354	
Glit	23445	Dry Polish Pad	17"	1	1.00 lbs.	0.145	
Glit	24159	Dry Polish Pad	17"	5	2.60 lbs.	1.089	
Glit	23446	Dry Polish Pad	19"	1	1.40 lbs.	0.178	
Glit	24163	Dry Polish Pad	19"	5	3.40 lbs.	1.354	
Glit	23447	Dry Polish Pad	20"	1	1.20 lbs.	0.178	
Glit	24161	Dry Polish Pad	20"	5	3.80 lbs.	1.354	
Glit	23651	Dry Polish Pad	27"	2	2.48 lbs.	0.165	
Glit	24162	Dry Polish Pad	27"	5	4.95 lbs.	2.608	

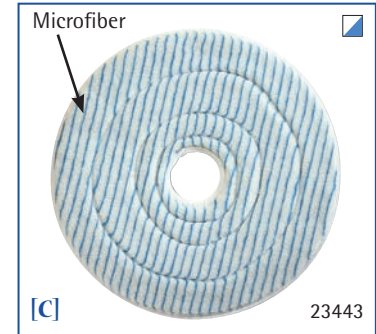
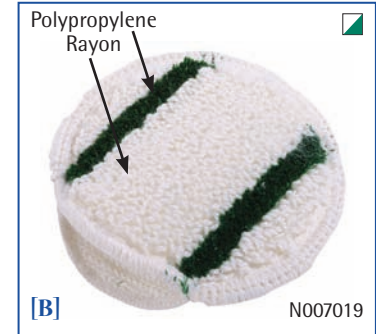
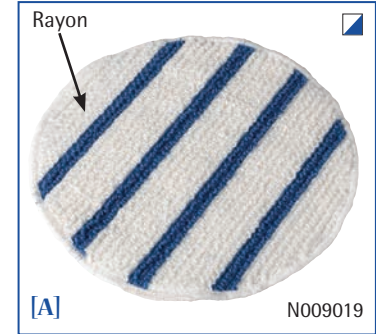



HAND PADS & SPONGES

A wide array of hand pads and scrubbing sponges to assist in a variety of markets and segments.

Ultra-Fresh™ is an antimicrobial treatment that has been applied to the products marked with the Ultra-Fresh™ logo. Ultra-Fresh™ protects the binding agent in the product, allowing it to control odors and fungal growth within the binder. This product does not protect users, or others, against bacteria, virus, germs or other disease causing organisms. Always clean and wash the product thoroughly before and after each use.

Revolutionary New Cellulose Alternative!

Made with a revolutionary sponge material, our new line of SpongePro™ and WipeClean Pro™ hand pads and sponges provide excellent cleaning and superior wipe dry performance. Combined with Glit's high-performing, non-woven material, our new line of hand pads offers traditional scrubbing capabilities with an innovative alternative to cellulose sponges!

[A] BLUE WALNUTPAD® SPONGEPRO™ EARTHTONE™

Combines our innovative sponge material with an organic compound which cleans without scratching. Safe to use on virtually any surface. Four "angle points" easily clean corners on counter tops, food pans and equipment. Designed to match the natural shape of your palm. Blue color easily identifies safe versus more abrasive pads that can scratch.

[B] WALNUTPAD® SPONGEPRO™ EARTHTONE™

Innovative sponge material absorbs water while the WalnutPad® helps cleaners work even better. Safe to use on stainless steel, copper, coated cookware and any surface where scratching is a concern.



Brand	Item #	Description	Size	Case Pack	Case Weight	Case Cu. Ft.	Stock Item
Glit	32050	Blue WalnutPad® SpongePro™	5 ³ / ₄ " x 3 ¹ / ₂ " x 3 ³ / ₄ "	20/bulk	1.20 lbs.	0.455	✓
Glit	32060	WalnutPad® SpongePro™	3 ¹ / ₈ " x 6 ¹ / ₄ " x 3 ³ / ₄ "	20/bulk	1.20 lbs.	0.455	✓

Ultra-Fresh® is a registered trademark of Thompson Research Associates, Inc.



HAND PADS & SPONGES

[A] MEDIUM-DUTY SPONGEPRO™ EARTHTONE™

Innovative sponge material attached to a medium-duty scouring pad. Absorbs liquid while the abrasive pad helps cleaners work even better. Works well on sinks, countertops, tables, walls, pots and pans. Rinses easily.

[B] LIGHT-DUTY SPONGEPRO™ EARTHTONE™

Innovative sponge material attached to a light-duty scouring pad. Excellent for cleaning countertops, appliances, ceramic tile, laminates, railings, sinks, tubs and showers.

[C] WIPECLEAN PRO™

Innovative sponge material features many advantages over traditional cellulose, with the added features of wipe-dry performance and an anti-microbial agent. Superior liquid holding capacity, softer and more flexible, longer-lasting and better liquid release. Remains odor-free and maintains its color for a longer period of time.



Brand	Item #	Description	Color	Size	Case Pack	Case Weight	Case Cubic Ft.	Stock Item
Glit	32020	Medium-Duty SpongePro™	Green / Yellow	3 ¹ / ₈ " x 6 ¹ / ₄ " x 3 ³ / ₄ "	4/10 pk.	2.00 lbs.	0.620	
Glit	32030	Medium-Duty SpongePro™	Green / Yellow	3 ¹ / ₈ " x 6 ¹ / ₄ " x 3 ³ / ₄ "	8/5 pk.	2.00 lbs.	0.620	
Glit	32010	Medium-Duty SpongePro™	Green / Yellow	3 ¹ / ₈ " x 6 ¹ / ₄ " x 3 ³ / ₄ "	40/bulk	2.00 lbs.	0.620	
Glit	32040	Medium-Duty SpongePro™	Green / Yellow	3 ¹ / ₈ " x 6 ¹ / ₄ " x 3 ³ / ₄ "	20/bulk	1.00 lbs.	0.455	
Glit	32070	Light-Duty SpongePro™	White / Yellow	3 ¹ / ₈ " x 6 ¹ / ₄ " x 3 ³ / ₄ "	40/bulk	1.90 lbs.	0.620	
Glit	32080	Light-Duty SpongePro™	White / Yellow	3 ¹ / ₈ " x 6 ¹ / ₄ " x 3 ³ / ₄ "	4/10 pk.	2.00 lbs.	0.620	
Glit	32100	Light-Duty SpongePro™	White / Yellow	3 ¹ / ₈ " x 6 ¹ / ₄ " x 3 ³ / ₄ "	20/bulk	1.00 lbs.	0.455	
Glit	32090	Light-Duty SpongePro™	White / Yellow	3 ¹ / ₈ " x 6 ¹ / ₄ " x 3 ³ / ₄ "	8/5 pk.	2.10 lbs.	0.620	
Glit	32110	WipeClean Pro™	Yellow	3 ³ / ₈ " x 6 ¹ / ₄ " x 1"	48/case	2.00 lbs.	0.760	✓
Glit	32120	WipeClean Pro™	Yellow	4 ¹ / ₈ " x 6 ¹ / ₄ " x 1 ⁵ / ₈ "	24/case	2.00 lbs.	0.760	✓
Glit	32130	WipeClean Pro™	Yellow	4 ³ / ₁₆ " x 7 ⁹ / ₁₆ " x 1 ¹¹ / ₁₆ "	24/case	3.00 lbs.	1.130	✓
Glit	32140	WipeClean Pro™	Yellow	4 ³ / ₁₆ " x 7 ⁹ / ₁₆ " x 1 ¹¹ / ₁₆ "	12/case	2.10 lbs.	0.640	✓

Ultra-Fresh® is a registered trademark of Thompson Research Associates, Inc.

Cellulose Sponges



[D] BLUE WALNUTPAD® SPONGE N' SCRUBBER EARTHTONE™

Utility cellulose sponge with scrubber that contains an organic compound which cleans without scratching. Safe to use on virtually any surface. Four "angle points" to easily clean corners on counter tops, food pans and equipment. Contoured to match the natural shape of your palm. Blue color for easy identification versus heavy and medium-duty pads that scratch.

[E] WALNUTPAD® SPONGE N' SCRUBBER EARTHTONE™

Utility cellulose sponge with a scratch resistant WalnutPad®. Cellulose sponge absorbs water while the WalnutPad® helps cleaners work even better. Safe to use on stainless steel, copper, coated cookware and any surface where scratching is a concern.



Brand	Item #	Description	Size	Case Pack	Case Weight	Case Cubic Ft.	Stock Item
Glit	20908	Blue WalnutPad® Sponge N' Scrubber	5 ³ / ₄ " x 3 ¹ / ₂ " x 3 ³ / ₄ "	20/bulk	1.20 lbs.	0.455	
Glit	29513	WalnutPad® Sponge N' Scrubber	3 ⁷ / ₁₆ " x 6 ¹ / ₄ "	20/bulk	1.20 lbs.	0.246	✓

Ultra-Fresh® is a registered trademark of Thompson Research Associates, Inc.



HAND PADS & SPONGES

[A] MEDIUM-DUTY SPONGE N' SCRUBBER **EARTHTONE™**

Utility cellulose sponge with medium-duty scouring pad attached. Cellulose sponge absorbs water while the green abrasive pad helps cleaners work even better. Works well on sinks, countertops, tables, walls, pots and pans. Rinses clean easily.

[B] LIGHT-DUTY SPONGE N' SCRUBBER **EARTHTONE™**

Utility cellulose sponge with light-duty scouring pad attached. Excellent for cleaning countertops, appliances, ceramic tile, laminates, railings, sinks, tubs and showers.

[C] CELLULOSE SPONGES

Biodegradable cellulose sponges will hold over 20 times their weight in liquid making them ideal for both pick-up and transfer of fluid. Ideal for countertops and formica surfaces.



Brand	Item #	Description	Color	Size	Case Pack	Case Weight	Case Cu. Ft.	Stock Item
Glit	20944	Medium-Duty Sponge N' Scrubber	Green / Yellow	3 ¹ / ₈ " x 6 ¹ / ₄ "	40/bulk	3.60 lbs.	0.587	✓
Glit	20945	Medium-Duty Sponge N' Scrubber	Green / Yellow	3 ¹ / ₈ " x 6 ¹ / ₄ "	4/10 pk.	2.60 lbs.	0.625	✓
Glit	23107	Medium-Duty Sponge N' Scrubber	Green / Yellow	3 ¹ / ₈ " x 6 ¹ / ₄ "	20/bulk	1.36 lbs.	0.255	✓
Glit	20946	Medium-Duty Sponge N' Scrubber	Green / Yellow	3 ¹ / ₈ " x 6 ¹ / ₄ "	8/5 pk.	3.00 lbs.	0.625	✓
Glit	20951	Light-Duty Sponge N' Scrubber	White / Yellow	3 ¹ / ₈ " x 6 ¹ / ₄ "	40/bulk	2.95 lbs.	0.613	✓
Glit	20952	Light-Duty Sponge N' Scrubber	White / Yellow	3 ¹ / ₈ " x 6 ¹ / ₄ "	4/10 pk.	3.24 lbs.	0.656	
Glit	23535	Light-Duty Sponge N' Scrubber	White / Yellow	3 ¹ / ₈ " x 6 ¹ / ₄ "	20/bulk	1.60 lbs.	0.255	✓
Glit	20953	Light-Duty Sponge N' Scrubber	White / Yellow	3 ¹ / ₈ " x 6 ¹ / ₄ "	8/5 pk.	3.30 lbs.	0.602	✓
Glit	26767	Cellulose Sponge	Yellow	3 ³ / ₈ " x 6 ¹ / ₄ " x 1"	48/case	4.20 lbs.	0.682	
Glit	26768	Cellulose Sponge	Yellow	4 ¹ / ₈ " x 6 ¹ / ₄ " x 1 ⁵ / ₈ "	24/case	4.00 lbs.	0.655	
Glit	26773	Cellulose Sponge	Yellow	4 ³ / ₁₆ " x 7 ⁹ / ₁₆ " x 1 ¹¹ / ₁₆ "	12/case	2.00 lbs.	0.380	
Glit	26769	Cellulose Sponge	Yellow	4 ³ / ₁₆ " x 7 ⁹ / ₁₆ " x 1 ¹¹ / ₁₆ "	24/case	5.35 lbs.	0.850	

Ultra-Fresh® is a registered trademark of Thompson Research Associates, Inc.

[D] POT & PAN SCRUBBER - BLUE **EARTHTONE™**

Hand-size, very abrasive scouring pad made for the toughest jobs, as well as those hard-to-clean areas. Popular for use in processing plants and on pots and pans. Because of its higher abrasion, in many cleaning situations, it can take the place of stainless steel or a metal scrubber.

[E] LIGHTWIPE - WHITE **EARTHTONE™**

Specially designed for cleaning porcelain dinnerware, enamel, stainless steel, brass, plexiglass, leaded glass, sneeze guards and copper cookware. Will not cause scratches that may dull and discolor fine surfaces.



Brand	Item #	Description	Color	Size	Case Pack	Case Weight	Case Cubic Ft.	Stock Item
Glit	20960	Pot & Pan Scrubber	Blue	3 ¹ / ₂ " x 5"	3/12	2.00 lbs.	0.444	✓
Glit	20961	Pot & Pan Scrubber	Blue	3 ¹ / ₂ " x 5"	4/10	1.80 lbs.	0.687	
Glit	20957	Lite Wipe	White	3 ¹ / ₂ " x 5"	40/bulk	1.40 lbs.	0.529	✓

Ultra-Fresh® is a registered trademark of Thompson Research Associates, Inc.



HAND PADS & SPONGES

[A] BLUE WALNUTPAD® EARTHTONE™

Contains an organic compound that cleans without scratching. Safe to use on virtually any surface. Four "angle points" to easily clean corners on counter tops, food pans, and equipment. Contoured to match the natural shape of your palm. Blue color for easy identification versus heavy and medium-duty pads that scratch.

[B] WALNUTPAD® EARTHTONE™

Scratch resistant hand pad with aggressive cleaning action. This unique pad contains crushed walnut shells which makes it safe to clean stainless steel, copper, coated cookware and any surface where scratching is a concern.



Brand	Item #	Description	Color	Size	Case Pack	Case Weight	Case Cubic Ft.	Stock Item
Glit	29523	Blue WalnutPad®	Blue	5 3/4" x 3 1/2"	20/bulk	1.00 lbs.	0.249	✓
Glit	29514	WalnutPad®	Brown	6" x 9"	20/bulk	1.00 lbs.	0.239	✓

Ultra-Fresh® is a registered trademark of Thompson Research Associates, Inc.



[C] HEAVY-DUTY SCOURING PAD - DARK GREEN EARTHTONE™

Very abrasive pad. Effective for removing heavy baked-on deposits, such as rust and corrosive deposits from metal surfaces. Ideal for hard-to-clean utensils and scuff marks on floors.

[D] MEDIUM-DUTY SCOURING PAD - GREEN EARTHTONE™

Our best seller! A general purpose cleaning pad, designed for daily cleaning of pots, pans, utensils, equipment and floors. Great for cleaning fresh vegetables. Not recommended for use on certain soft plastics, fine china or polished stainless steel.

[E] MEDIUM-DUTY SCOURING PAD - GREEN EARTHTONE™

General purpose thick pad for cleaning pots and pans, cooking utensils, equipment, floors, walls and counters. Its small, hand-size eliminates the need to fold or cut the pad.

[F] LIGHT-DUTY SCOURING PAD - WHITE EARTHTONE™

Light abrasive pad for cleaning fine surfaces such as porcelain, non-stick cookware, ceramic tile, plastics, stoves and terrazzo floors.



Brand	Item #	Description	Color	Size	Case Pack	Case Weight	Case Cubic Ft.	Stock Item
Glit	20954	Heavy-Duty Scouring Pad	Dark Green	6" x 9"	6/10	5.20 lbs.	1.279	✓
Glit	20955	Heavy-Duty Scouring Pad	Dark Green	6" x 9"	60/bulk	5.20 lbs.	1.187	✓
Glit	22584	Heavy-Duty Scouring Pad	Dark Green	6" x 9"	3/12	4.20 lbs.	0.815	
Glit	20940	Medium-Duty Scouring Pad	Green	6" x 9"	6/10	3.67 lbs.	0.863	✓
Glit	20941	Medium-Duty Scouring Pad	Green	6" x 9"	60/bulk	3.80 lbs.	0.885	✓
Glit	20942	Medium-Duty Scouring Pad	Green	6" x 9"	3/20	4.00 lbs.	0.846	✓
Glit	20958	Medium-Duty Scouring Pad	Green	3 1/2" x 5"	40/bulk	1.40 lbs.	0.454	✓
Glit	20959	Medium-Duty Scouring Pad	Green	3 1/2" x 5"	60/bulk	2.10 lbs.	0.841	
Glit	20948	Light-Duty Scouring Pad	White	6" x 9"	6/10	2.40 lbs.	0.841	✓
Glit	20949	Light-Duty Scouring Pad	White	6" x 9"	60/bulk	2.40 lbs.	0.841	✓
Glit	20950	Light-Duty Scouring Pad	White	6" x 9"	3/20	2.40 lbs.	0.841	

Ultra-Fresh® is a registered trademark of Thompson Research Associates, Inc.



HAND PADS & SPONGES

The Color Code-It System is specially designed for food processing and preparation, grocery supermarket and healthcare applications, to reduce the likelihood of cross contamination. Hand pads, by color, are designated for specific areas. These color-coded pads will not rust or splinter and easily conform to cracks and crevices. Approved for usage in the meat and poultry industry. Washable for re-use.

[A] COLOR-CODE-IT PADS **EARTHTONE™**

RED HAND PAD: MEDIUM DUTY

For receiving/raw materials and raw meat areas.

GREEN HAND PAD: MEDIUM DUTY

For prep/wash size reduction areas, produce areas and rest rooms.

YELLOW HAND PAD: LIGHT DUTY

For process - non-food contact surface areas, general clean-up of non-food contact surface areas and patient areas.

TAN HAND PAD: LIGHT DUTY

For contaminated surface areas, poultry and general purpose areas.

BLUE HAND PAD: LIGHT DUTY

For packaging and seafood areas and emergency rooms.

WHITE HAND PAD: LIGHT DUTY

For process - food contact surface areas, cooked, processed and prepared food areas.

WALNUTPAD®: SCRATCH RESISTANT

For public areas, bakery areas and for common areas.



[A]

29304 / 29306 / 29305 / 29302 / 29303 / 29301 / 29307

Brand	Item #	Description	Color	Size	Case Pack	Case Weight	Case Cubic Ft.	Stock Item
Glit	29304	Medium-Duty Hand Pad	Red	6" x 9"	20/bulk	1.30 lbs.	0.249	✓
Glit	29302	Medium-Duty Hand Pad	Green	6" x 9"	20/bulk	1.20 lbs.	0.249	✓
Glit	29305	Light-Duty Hand Pad	Yellow	6" x 9"	20/bulk	1.00 lbs.	0.249	✓
Glit	29307	Light-Duty Hand Pad	Tan	6" x 9"	20/bulk	1.00 lbs.	0.249	
Glit	29306	Light-Duty Hand Pad	Blue	6" x 9"	20/bulk	1.00 lbs.	0.249	✓
Glit	29301	Light-Duty Hand Pad	White	6" x 9"	20/bulk	0.93 lbs.	0.249	✓
Glit	29303	WalnutPad® Scratch Resistant	Brown	6" x 9"	20/bulk	1.10 lbs.	0.249	

FOR USE WITH INDUSTRIAL SOLVENT CLEANERS.

A superior range of non-woven synthetic fiber pads coated with abrasive and bonded together with a special adhesive system to withstand harsh industrial solvents. For industrial use in cleaning, finishing and preparing metals and wood surfaces.

[B] INDUSTRIAL PADS

INDUSTRIAL TAN:

For demanding finishing or cleaning machinery and equipment. Fast removal of rust, oxidation and corrosion.

INDUSTRIAL MAROON:

Great for cleaning machinery or surface preparation for coating and lamination.

INDUSTRIAL GREEN:

For removing deposits of rust or corrosion.

INDUSTRIAL GREY:

For fine cleaning and finishing requirements, and rubbing down primers and sealers.

Removes scratches on metal surfaces, smoothing base wood and rubbing in furniture oils.



[B]

26040 / 26041 / 26042 / 26044

Brand	Item #	Description	Color	Size	Case Pack	Case Weight	Case Cubic Ft.	Stock Item
Glit	26042	Industrial Tan	Tan	6" x 9"	4/10	7.00 lbs.	0.454	
Glit	26041	Industrial Maroon	Maroon	6" x 9"	3/20	6.00 lbs.	0.841	
Glit	26044	Industrial Green	Green	6" x 9"	3/20	4.00 lbs.	0.454	
Glit	26040	Industrial Grey	Grey	6" x 9"	3/20	4.80 lbs.	0.841	



HAND PADS & SPONGES

[A] STEEL WOOL SOAP PADS

Made of fine steel wool formed into a large "hotel size" soap impregnated pad. Dissolves stubborn grease and lifts-off sticky food particles leaving behind a bright new shine. Not recommended for soft plastics or fine china. Available in the Brillo® branded box or our generic poly bag that is reclosable.

Brand	Item #	Description	Size	Inner Packaging	Case Pack	Case Weight	Case Cubic Ft.	Stock Item
Glit	29404	Brillo®	4" x 4"	Box	12/10	12.20 lbs.	1.255	✓
Glit	29405	Generic	4" x 4"	Poly Bag	12/10	11.60 lbs.	1.078	✓



BRUSHES & SCRUBS

These versatile brushes are great for a wide range of uses in every environment. Constructed with either structural foam or hardwood blocks, they feature a variety of bristle types.

[B] RADIATOR BRUSH



Thin profile allows bristles to get into tight spaces like radiators, vents and coils. Also a great counter or workbench duster. Natural lacquered hardwood handle with hang-hole for easy storage.

Brand	Item #	Handle Type	Bristle Color	Bristle Trim	Case Pack	Case Weight	Case Cu. Ft.	Stock Item
Wilco	E409100	Wood	Natural	2 1/2"	12	4.00 lbs.	0.444	✓

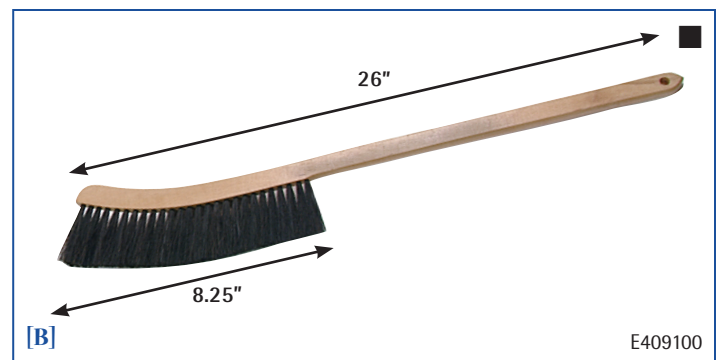

ECONOMICAL SCRUB

Economic designs allow more efficient cleaning with these high quality scrub brushes designed to help you work smarter, not harder.

[C] HANDLE SCRUB



Get a good grip on routine cleaning jobs! This highly versatile brush is easy to hold and simple to use. Crimped polypropylene fiber provides long lasting wear. Also great on upholstery and vinyl.

Brand	Item #	Handle Type	Bristle Color	Bristle Trim	Case Pack	Case Weight	Case Cu. Ft.	Stock Item
Wilco	I601000	6" Plastic	White	1"	12	4.00 lbs.	0.324	✓

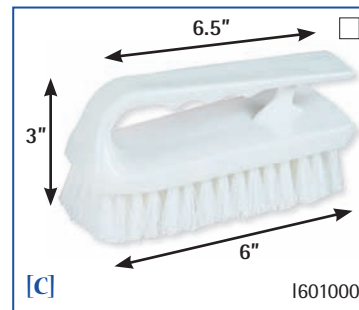

TOUGH SCRUB BRUSHES WITH HANDLES

Our utility Tough Scrub brushes are available in lacquered hardwood, structural foam and molded plastic blocks - all with non-slip handle grips and hang-up holes. These versatile brushes are great for a variety of uses in every environment. Choose the 8.5" size to eliminate knuckle scrapes common with hand scrubs or the 20" size for deep cleaning in vats, pots and buckets.

[A] CRIMPED POLYPROPYLENE TOUGH SCRUB

This utility brush is ideal for general maintenance applications. Crimped fibers provide excellent scrubbing power and chemical resistance. Handle allows easy access to tight places for quick cleaning.

[B] HEAVY POLYPROPYLENE TOUGH SCRUB

This all-purpose brush is great for virtually any scrubbing job in industrial and commercial settings. The flared, sturdy fibers are ideal for cleaning in cramped places and are resistant to most chemicals.

[C] WHITE TAMPICO TOUGH SCRUB

Natural bristles provide excellent liquid retention for general cleaning. Durable, all-purpose brush won't scratch and is highly resistant to cleaners and chemicals.

[D] PALMYRA TOUGH SCRUB

Tough, durable scrubber is ideal for heavy-duty jobs and single use applications. Economical brush features stiff fibers which stand up to rugged scrubbing.

[E] CRIMPED NYLON TOUGH SCRUB

Ideal for kitchen scrubbing and other tough jobs. Fibers are flared to get into tight places and clean quickly. White plastic block is virtually unbreakable.



[A] I301120 / I301108



[B] I302120 / I302108



[C] I303120 / I303108



[D] I304120 / I304008



[E] I502220 / I502208

Brand	Item #	Handle Type	Bristle Color	Bristle Trim	Case Pack	Case Weight	Case Cu. Ft.	Stock Item
Wilco	I301108	8 1/2" Foam	Blue	2"	12	6.00 lbs.	0.698	✓
Wilco	I301120	20" Foam	Blue	2"	12	10.00 lbs.	1.289	✓
Wilco	I302108	8 1/2" Foam	Green	2"	12	6.00 lbs.	0.698	✓
Wilco	I302120	20" Foam	Green	2"	12	10.00 lbs.	1.289	✓
Wilco	I303008	8 1/2" Wood	Natural	2"	12	7.00 lbs.	0.698	✓
Wilco	I303020	20" Wood	Natural	2"	12	11.00 lbs.	1.289	✓
Wilco	I303108	8 1/2" Foam	Natural	2"	12	7.00 lbs.	0.698	✓
Wilco	I303120	20" Foam	Natural	2"	12	11.00 lbs.	1.289	✓
Wilco	I304008	8 1/2" Wood	Brown	2"	12	6.00 lbs.	0.698	✓
Wilco	I304020	20" Wood	Brown	2"	12	10.00 lbs.	1.289	✓
Wilco	I304108	8 1/2" Foam	Brown	2"	12	6.00 lbs.	0.698	✓
Wilco	I304120	20" Foam	Brown	2"	12	10.00 lbs.	1.289	✓
Wilco	I502208	8 1/2" Plastic	Clear	2"	12	7.00 lbs.	0.698	✓
Wilco	I502220	20" Plastic	Clear	2"	12	9.00 lbs.	1.289	✓

FLOOR SCRUBS

Use any standard threaded handle on these tough scrubbers to scrub floors, baseboards - even walls.

[A] MULTI-LEVEL SCRUB BRUSH

Crimped polypropylene fibers provide long service even with solvents and other harsh chemicals. The unique shape of this brush makes it easy to clean a wide variety of surfaces like baseboards, under counters and around equipment in many settings. Durable, structural foam block.

[B] SWIVET SCRUB™

Special universal joint allows brush to swivel and lock into any position to clean corners, baseboards and around fixtures. Structural foam block swivels to allow access to hard to reach areas. Available with crimped yellow polypropylene (1/4" trim) or 120 grit (3/4" trim) fibers.

[C] BASEBOARD BRUSH

Designed to ease the tedious task of cleaning baseboards. Angled, crimped polypropylene fibers allow you to easily clean hard to reach corners, baseboards and stairways.

Brand	Item #	Handle Type	Bristle Color	Bristle Trim	Case Pack	Case Weight	Case Cu. Ft.	Stock Item
Wilco	I004000	10" Foam	Blue	1 3/4"	12	16.00 lbs.	1.325	✓
Wilco	I005100	8 1/2" Foam	Yellow	1 1/4"	12	8.00 lbs.	0.973	✓
Wilco	F501000	5 1/2" Foam	Black	2"	12	9.00 lbs.	0.998	✓



Floor Scrubs accept threaded handles only. Found on page 51

DECK BRUSHES

Our tough scrubbing deck brushes are constructed with a smooth hardwood block with tapered and threaded handle holes. Ideal for a wide variety of surfaces including decks, patios, driveways, garages, drive-thrus and walkways. Handles sold separately.

[D] CRIMPED POLYPROPYLENE DECK BRUSH

These chemical resistant bristles are ideal for scrubbing any dirt on smooth surfaces. Crimped trim provides aggressive action.

[E] PALMYRA DECK BRUSH

This sturdy and dependable brush is ideal for hard, rugged scrubbing on rough surfaces. Removes the heavy, dried dirt easily.

[F] WHITE TAMPICO DECK BRUSH

These durable, liquid retaining bristles are ideal for all types of scrubbing on smooth and rough surfaces. Makes clean-up quick and easy.

Brand	Item #	Handle Type	Bristle Color	Bristle Trim	Case Pack	Case Weight	Case Cu. Ft.	Stock Item
Wilco	I001010	10" Wood	Yellow	2"	12	12.00 lbs.	0.822	✓
Wilco	I001012	12" Wood	Yellow	2"	12	14.00 lbs.	0.973	✓
Wilco	I002010	10" Wood	Brown	2"	12	11.00 lbs.	0.822	✓
Wilco	I002012	12" Wood	Brown	2"	12	14.00 lbs.	0.973	✓
Wilco	I003010	10" Wood	Natural	2"	12	13.00 lbs.	0.822	✓
Wilco	I003012	12" Wood	Natural	2"	12	15.00 lbs.	0.973	✓

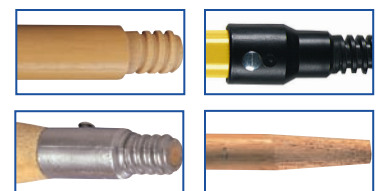
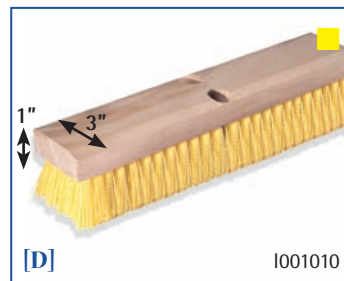

Deck Scrubs accept both threaded and Tapered handles. Found on page 51

WIRE BRUSHES

This durable wire scratch brush line treats a wide variety of surfaces with strong pressure and tough fibers. Wire scratch blocks are constructed with long-lasting, traditional hardwood and come with a hang-up hole.

[A] CURVED HANDLE WIRE SCRATCH

3 x 19 rows of tempered steel wire. This general purpose wire scratch, available with or without scraper, is best in industrial and commercial areas. Designed for scraping all types of surfaces.

[B] SHOE HANDLE WIRE SCRATCH

4 x 16 rows of tempered steel wire. The shoe handle wire scrub provides a strong grip, while the scraper provides extra pressure for difficult jobs. Ideal for removing paint, rust and grease from masonry, wood or pipes.

[C] DETAIL BRUSHES

Available in three fibers with a plastic handle. Brass fibers are static-free, nylon fibers are chemical resilient and add extra durability. Stainless fibers are great for resistance to corrosion and high temperature.

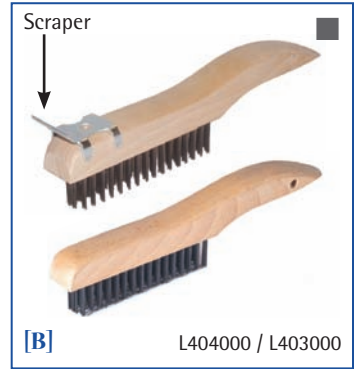
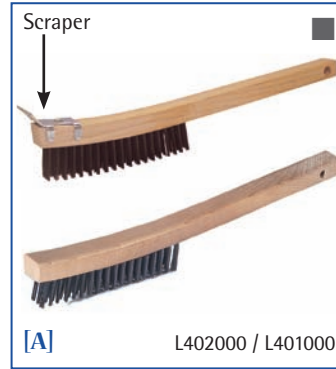

Brand	Item #	Handle Type	Bristle Color	Bristle Type	Bristle Trim	Case Pack	Case Weight	Case Cu. Ft.	Stock Item
Wilco	L401000	14" Wood	Grey	Steel	1"	12	5.00 lbs.	0.280	✓
Wilco	L402000	14" Wood w/ scraper	Grey	Steel	1"	12	6.00 lbs.	0.280	✓
Wilco	L403000	10 1/4" Wood	Grey	Steel	1"	12	5.00 lbs.	0.280	✓
Wilco	L404000	10 1/4" Wood w/ scraper	Grey	Steel	1"	12	5.00 lbs.	0.280	✓
Wilco	L407124	9" Plastic	Gold	Brass	1/2"	24	1.00 lb.	0.094	✓
Wilco	L407224	14" Wood	Black	Nylon	1/2"	24	1.00 lb.	0.094	✓
Wilco	L407324	14" Wood	Grey	Steel	1/2"	24	1.00 lb.	0.094	✓

VEHICLE BRUSHES

Vehicle washers with scratchless fibers and rubber bumpers keep vehicles in tip top appearance. Blocks are available in structural foam, which will not split or splinter. The threaded handle hole features a flow-through design for attaching to a fountain handle and water hose. Handles sold separately. Also great for windows, siding and awnings.

[D] FLAGGED NYLON WASHER

Tough, white nylon with feathered tips allows scratchless cleaning of exterior surfaces and has exceptional wearing abilities. Fiber is resistant to all common cleaners, detergents, acids or alkalis. Perfect for auto, truck and aluminum siding. Will not mat or absorb odors.

[E] FLAGGED POLYSTYRENE WASHER

Perfect for auto, truck, RV, bus, boat, airplane or any vehicle. Flagged fiber provides non-scratch performance.

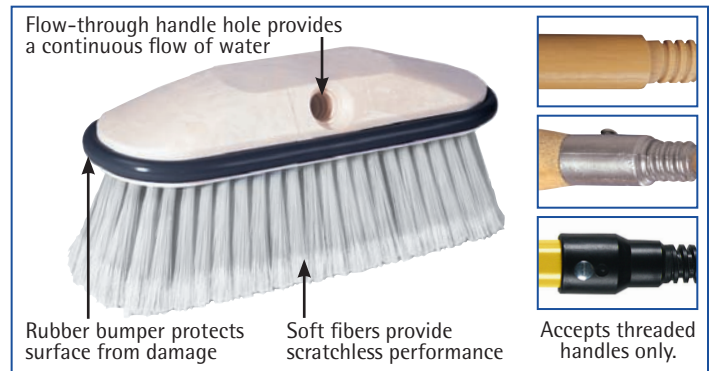

Brand	Item #	Handle	Bristle Color	Bristle Trim	Case Pack	Case Weight	Case Cu. Ft.	Stock Item
Wilco	K001000	9" Foam	White	2 1/2"	12	12.00 lbs.	1.263	✓
Wilco	K003000	9" Foam	Grey	2 1/2"	12	15.00 lbs.	1.263	✓

HAND & NAIL BRUSHES

Hand and nail brushes are ideal for complete sanitation or removing dirt from hands after industrial outdoor work.

[A] DELUXE HAND AND NAIL BRUSH

Crimped polypropylene fibers provide long service even with solvents and other harsh chemicals. The unique shape of this brush makes it easy to clean a wide variety of surfaces like baseboards, under counters and around equipment in food service or industrial settings. Durable, structural foam block.



Brand	Item #	Block	Bristle Color	Bristle Type	Bristle Trim	Case Pack	Case Weight	Case Cu. Ft.	Stock Item
Wilco	J401000	5" x 2 ³ / ₄ " Plastic	White	Nylon	³ / ₄ "	12	5.00 lbs.	0.107	✓

SPECIALTY BRUSHES

Here's the easy, sanitary way to manually clean glassware.

[B] GLASS WASHER

Polyester fiber provides scratchless cleaning of glassware and fits most standard glasswasher units. White structural foam block.



Brand	Item #	Description	Bristle Color	Bristle Type	Bristle Trim	Case Pack	Case Weight	Case Cu. Ft.	Stock Item
Wilco	J005000-01	Refill Brush	Black	Polyester	2 ⁷ / ₈ "	12	3.00 lbs.	0.428	✓
Wilco	J005002-01	Twin / 7 ¹ / ₄ " x 4"	Black	Polyester	2 ⁷ / ₈ "	6	5.00 lbs.	2.817	✓
Wilco	J005003-01	Triple / 7 ¹ / ₄ " x 4"	Black	Polyester	2 ⁷ / ₈ "	6	10.00 lbs.	2.817	✓



Use wet for general cleaning or dry for dusting. Super absorbent fibers hold several times their weight in liquid. Color-coded to ensure proper usage.

MICROFIBER CLOTHS

Wilens® offers both a premium Supremo™ line and a value-based Standard line in a lighter weight. Both lines use the highest quality, lint-free microfiber. These cloths are extremely durable and can be laundered hundreds, even thousands of times!

[A] SUPREMO™ MICROFIBER CLOTHS    **EARTHTONE™**
A 45-50 gram, all-purpose cleaning cloth that contains 70% polyester and 30% polyamide. Great for dusting and cleaning all types of surfaces.

[B] STANDARD MICROFIBER CLOTHS    **EARTHTONE™**
This economical cloth weighs 30-35 grams and contains 80% polyester and 20% polyamide. Ideal for bid situations.

[C] GLASSIC™ MICROFIBER CLOTHS    **EARTHTONE™**
Ideal for cleaning soap, grease or finger prints from windows, mirrors and metal surfaces. Leaves a streak-free finish.

Brand	Item #	Item	Size	Color	Case Pack	Case Weight	Case Cubic Ft.	Stock Item
Wilens	E800016	Supremo™ Microfiber Cloths	16" x 16"	Green	12	2.00 lbs.	0.296	✓
Wilens	E801016	Supremo™ Microfiber Cloths	16" x 16"	Green	180	20.00 lbs.	2.400	✓
Wilens	E810016	Supremo™ Microfiber Cloths	16" x 16"	Blue	12	2.00 lbs.	0.296	✓
Wilens	E811016	Supremo™ Microfiber Cloths	16" x 16"	Blue	180	20.00 lbs.	2.400	✓
Wilens	E820016	Supremo™ Microfiber Cloths	16" x 16"	Red	12	2.00 lbs.	0.296	✓
Wilens	E821016	Supremo™ Microfiber Cloths	16" x 16"	Red	180	20.00 lbs.	2.400	✓
Wilens	E830016	Supremo™ Microfiber Cloths	16" x 16"	Yellow	12	2.00 lbs.	0.296	✓
Wilens	E831016	Supremo™ Microfiber Cloths	16" x 16"	Yellow	180	20.00 lbs.	2.400	✓
Wilens	E840016	Supremo™ Microfiber Cloths	16" x 16"	Pink	12	2.00 lbs.	0.296	✓
Wilens	E841016	Supremo™ Microfiber Cloths	16" x 16"	Pink	180	20.00 lbs.	2.400	✓
Wilens	E700016	Standard Microfiber Cloths	16" x 16"	Green	12	1.50 lbs.	0.190	✓
Wilens	E710016	Standard Microfiber Cloths	16" x 16"	Blue	12	1.50 lbs.	0.190	✓
Wilens	E720016	Standard Microfiber Cloths	16" x 16"	Red	12	1.50 lbs.	0.190	✓
Wilens	E730016	Standard Microfiber Cloths	16" x 16"	Yellow	12	1.50 lbs.	0.190	✓
Wilens	E850016	Classic™ Microfiber Cloths	16" x 16"	Light Blue	12	2.00 lbs.	0.296	✓
Wilens	E851016	Classic™ Microfiber Cloths	16" x 16"	Light Blue	216	20.00 lbs.	2.400	✓



[A] Supremo™ Assortment



[B] Standard Assortment



[C] E850016

DUSTERS

Dust is everywhere, especially in hard-to-reach areas. Reach those tough spots with a choice of brush fiber or yarn based dusters. Our high-reach dusters feature extendable handles for reaching light fixtures, corners, vents, fan blades and window blinds.

HIGH DUSTERS

[A] SUPREMO™ DUSTER EARTHSTONE™

Extendable handle reaches from 26" to 46". Microfiber strands maximize surface area. Removable sleeve can be washed up to 300 times!

[B] COBWEB DUSTER

Synthetic fibers hold dust with electro-static action. Comes complete with plastic coated, metal handle that extends to 60" and features a convenient hang-up hole. Gets in those hard-to-reach high areas, such as corners and vaulted ceilings where cobwebs accumulate. Great for blinds, furniture, vents and baseboards. Easy to keep clean—just swirl in warm sudsy water and air dry.

[C] DELUXE SPLIT DUSTER

Specially designed to clean blinds, fan blades, furniture and other narrow and hard-to-reach objects. Launderable head is constructed of durable cotton yarn. Deluxe Split Duster features threaded, plastic-coated wire frame with Velcro® fastener allows fast and easy attachment of refillable head.

[D] EXTEND-TO-REACH DUSTER

Extend your reach with these versatile and efficient dusters. Metal handle extends from 34" to 60" and locks into place with a simple twist, allowing users to reach out of the way places like corners and vents. Removable yarn heads are secured to handle with Velcro®, and are launderable.

[E] PIPE DUSTER

Contoured frame is designed for cleaning overhead pipes, ducts and other hard to reach areas. Long staple cotton yarn head is launderable. Pipe Duster features metal wire frame with 60" fiberglass handle and refill with ties.

[F] MICROFLEX™ DUSTER EARTHSTONE™

The latest in Microfiber technology. Flexible thin foam frame allows effective cleaning in tight, hard-to-reach areas. Frame accepts a hand held handle or either one of our Pro Flat mop handles for high area cleaning. Microfiber refills provide durability and long product life. Simply rinse away dirt with water after every use. Duster refill available separately.



A-C High Dusters accept threaded handles only. Found on page 51

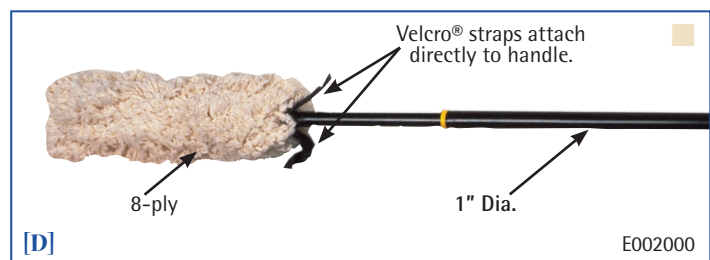
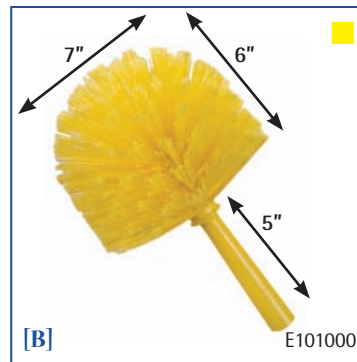

Brand	Item #	Description	Fiber Color	Fiber Type	Case Pack	Case Weight	Case Cubic Ft.	Stock Item
Wilco	E225000	Supremo™ Duster w/ Handle	Blue	Microfiber	12	11.00 lbs.	1.440	✓
Wilco	E001000	Cobweb Duster / Complete	Yellow or Blue	PVC	6	9.00 lbs.	4.090	✓
Wilco	E101000	Cobweb Duster / Head Only	Yellow or Blue	PVC	6	4.00 lbs.	4.090	✓
Wilco	E120000	Deluxe Split Duster / Refill	Natural	Cotton	12	3.00 lbs.	0.564	✓
Wilco	E320000	Deluxe Split Duster / Frame	N/A	N/A	12	5.00 lbs.	0.920	✓
Wilco	E002000	Extend-To-Reach Duster / Complete	Natural	Cotton	12	12.00 lbs.	1.030	✓
Wilco	E102000	Extend-To-Reach Duster / Refill	Natural	Cotton	12	4.00 lbs.	0.920	✓
Wilco	E317000	Pipe Duster / Frame & Handle	N/A	N/A	12	20.00 lbs.	2.682	✓
Wilco	E117000	Pipe Duster / Refill	Natural	Cotton	12	6.00 lbs.	0.564	✓
Wilco	E224000	Microflex™ Duster / Complete, 2" x 27"	Blue	Microfiber	1	0.16 lbs.	0.170	✓
Wilco	E224100	Microflex™ Duster / Refill, 2" x 22"	Blue	Microfiber	3	0.06 lbs.	0.060	✓

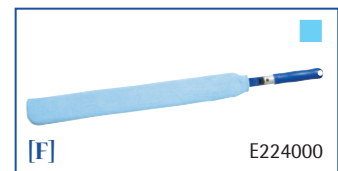

COUNTER DUSTERS

Our quality dusters help keep counters, table tops, shelving, cupboards and equipment clean. Blocks are available in a structural foam that will not split or splinter. Blocks come with hang-up hole.

[A] FLAGGED POLYPROPYLENE



The flagged tips of this bristle make it the ideal tool for fine dust and dirt removal on smooth surfaces. It is great for shops, light industrial and commercial uses.

[B] BLACK TAMPICO



Great all around duster with full body, flexibility and long wearing quality. Black tampico is the premier all-purpose fiber for smooth and rough surfaces. Most commonly used to dust equipment and pick up metal chips and dirt.

[C] POLYPROPYLENE



Medium stiff fibers are great for all-purpose dusting. 8" structural foam block.

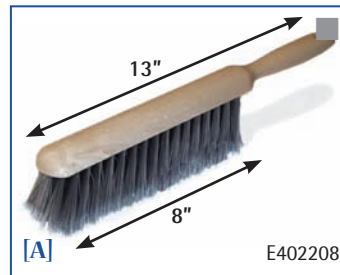

Brand	Item #	Description	Bristle Color	Bristle Type	Bristle Trim	Handle	Case Pack	Case Weight	Case Cu. Ft.	Stock Item
Wilco	E402208	Flagged Polypropylene	Grey	Synthetic	2 1/2"	Foam	12	9.00 lbs.	0.064	✓
Wilco	E403208	Black Tampico	Black	Tampico	2 1/2"	Foam	12	8.00 lbs.	0.064	✓
Wilco	E408208	Polypropylene	Black	Synthetic	2 1/2"	Foam	12	8.00 lbs.	0.064	✓

DUST CLOTHS, TOWELS & MITTS

Our specialized dust cloths and wipes make cleaning fast and easy. These durable and economical tools are designed to pick up dust and dirt instead of scattering.

[D] HEAVY-DUTY DUSTING MITT



EARTHTONE™

Microfiber strands maximize surface area, making this tool ideal for dusting contoured surfaces. Dusting can be done using either side.

[E] UTILITY DUST & WASH MITT



Versatile hand mitt which can be used for washing and dusting. Constructed of permatwist yarn for maximum durability. Great for dusting furniture and equipment as well as washing cars, outdoor furniture and other items requiring hand cleaning.

[F] TREATED DUST CLOTH



Treated flannel dust cloth is great for common dusting chores. Treatment allows maximum dust collection and retention. Available as individual poly-bagged cloths or economical rolls.

[G] MAGNA THIRSTY TOWEL



Economical alternative to rental towels. 18" x 22" towels absorb better than cotton and are very launderable. Lint free material makes them useful for high-tech, health care and food service use, as well as for users who demand extra durability and absorbency. Bulk packed 50 in dispenser case.

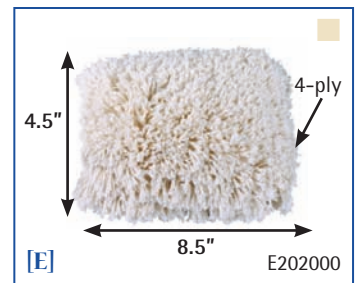

Brand	Item #	Description	Color	Size	Case Pack	Case Weight	Case Cubic Ft.	Stock Item
Wilco	E228000	Heavy Duty Dusting Mitt	Grey	7 1/2" x 9 1/4"	12	2.00 lbs.	0.200	✓
Wilco	E202000	Utility Dust & Wash Mitt	Natural	10" x 6"	12	4.00 lbs.	0.920	✓
Wilco	E204024	Treated Dust Cloth	Yellow	18" x 24"	12	2.00 lbs.	0.375	✓
Wilco	E205025	Treated Dust Cloth	Yellow	Roll: 36" wide x 25 yds.	1	17.00 lbs.	2.062	✓
Wilco	E206010	Treated Dust Cloth	Yellow	Roll: 46" wide x 10 yds.	2	9.00 lbs.	1.963	✓
Wilco	E208000	Magna Thirsty Towel	White	18" x 22"	50	4.00 lbs.	0.064	✓

WALL WASHERS

Our convenient and economic dust collection tools are perfect for offices, schools, stores and other commercial environments. These products are designed to pick up dust and dirt instead of spreading it along the surface.

[A] UNIVERSAL WALL WASHER

Great for washing walls and for use as a duster for out-of-the-way areas. Free swiveling Universal frame features notches for locking in angles. Detachable head for laundering.

[B] STICK-M™ WALL WASHER

Hi-wet modulus rayon looped yarn is highly absorbent and launderable. Velcro® attachment to high-impact plastic holder assures easy changes. Holder may be used in any standard side-squeeze wringer. Holder also features 360° swivel action.

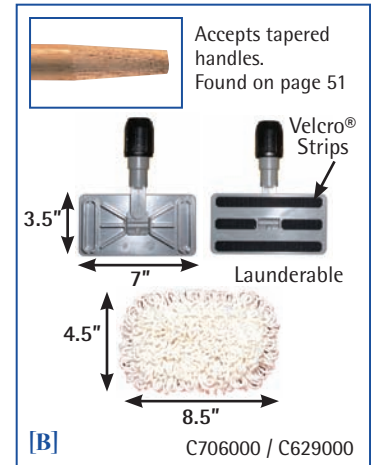
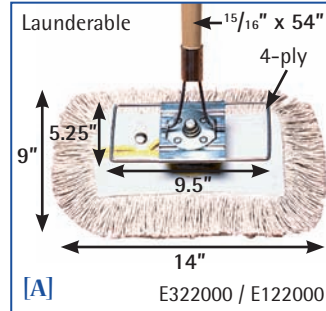

Brand	Item #	Description	Color	Size	Case Pack	Case Weight	Case Cubic Ft.	Stock Item
Wilco	E322000	Universal Frame Handle	Wood	15 1/16" x 54" / 9.5" x 5.25"	12	10.00 lbs.	0.857	✓
Wilco	E122000	Universal Frame Handle Refills	Natural	14" x 9"	12	5.00 lbs.	0.564	✓
Wilco	C706000	Stick-M™ Holder	Grey	7" x 3.5"	12	5.00 lbs.	0.920	✓
Wilco	C629000	Stick-M™ Refills	Natural	8.5" x 4.5"	12	5.00 lbs.	0.564	✓

BUCKETS

Our buckets and pails feature heavy-duty, thick-wall construction. Easy to clean surfaces, rugged handles and molded-in graduations make these products easy to use. Choose from several styles and types.

[C] HUSKEE® BUCKET

Features durable steel handle and built-in pour spout. Available in ten and 14 quart capacities. Graduations are molded inside.

[D] PREPRINTED HUSKEE® BUCKETS

Same features as the traditional Huskee™ Buckets, but hot stamped with either of two messages: "Broken Glass" or "Sanitizer." Ideal for restaurants and required by HACCP Standards.



Brand	Item #	Size	Color	Case Pack	Case Weight	Case Cu. Ft.	Stock Item
Continental	8110GY	10 qt.	Grey	12	15.60 lbs.	2.520	✓
Continental	8110RD	10 qt.	Red	12	15.60 lbs.	2.520	✓
Continental	8110WH	10 qt.	White	12	15.60 lbs.	2.520	✓
Continental	8114GY	14 qt.	Grey	6	11.40 lbs.	2.040	✓
Continental	8114RD	14 qt.	Red	6	11.40 lbs.	2.040	✓
Continental	8114WH	14 qt.	White	6	11.40 lbs.	2.040	✓
Continental	8110RDGM	10 qt.	Red	12	15.60 lbs.	2.520	✓
Continental	8110WHGM	10 qt.	White	12	15.60 lbs.	2.520	✓



BUCKETS

[A] HUSKEE® DIVIDED PAIL

Rugged commercial buckets with insulated hand grip. Divided Pail allows separation of cleaning solution from rinse water.

[B] UTILITY / SQUEEGEE BUCKET

Heavy-duty bucket with ergonomic plastic handle bail. Wheel Kit aids in maneuverability.

[C] UTILITY / SQUEEGEE BUCKET WHEEL SET

[D] HUSKEE® HAULER

19 gallon capacity with rope handles. Ideal for bulk storage, completely nestable.

Brand	Item #	Size	Color	Case Pack	Case Weight	Case Cu. Ft.	Stock Item
Continental	8216	16 qt.	Grey	6	14.28 lbs.	3.120	✓
Continental	2559	24 qt.	Blue	3	9.96 lbs.	2.640	✓
Continental	2560	- - -	Black	3 sets	1.50 lbs.	0.060	✓
Continental	8119RD	6 gal.	Red	6	27.00 lbs.	8.880	✓



SPRAYERS & PUMPS

Our full line of sprayers and dispensers are ideal for general maintenance applications. Sprayers are made with high quality components and are chemical resistant.

SPRAYERS

[E] PROSAFE™ SPRAYER

These bottles come in a pack of three, have a product check-off grid and provide trilingual (English/Spanish/French) information to comply with the "Right to Know" regulations. 24 ounce bottle with 902 sprayer.

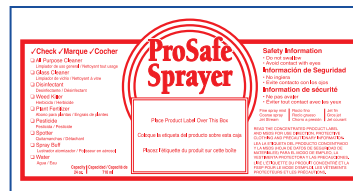

Brand	Item #	Size	Color	Case Pack	Case Weight	Case Cu. Ft.	Stock Item
Continental	902-3RW	24 oz.	Clear/Rd/Wh	32 sets of 3 (96)	20.75 lbs.	5.910	✓



SPRAYERS

[A] PLASTIC BOTTLES

Continental® bottles are molded of high density polyethylene. All bottles are standard with a 28/400 neck finish and molded in graduations.

[B] HIGH OUTPUT SPRAYER

The largest capacity trigger sprayer available today. Outputs 3.3cc per stroke. Adjustable from a fine mist to a jet stream and has a full "off" position. Completely leak proof, even if overturned. Oversized ergonomic trigger reduces operator fatigue and provides comfort and control. Comes standard with a 28/400 closure and dip tube filter.

[C] SPRAY-PRO SPRAYER

Designed for heavy-duty, long-term industrial applications ranging from car care to window cleaners. The Continental® 902 Trigger Sprayer is capable of delivering a consistent spray pattern that is adjustable from a full "off" position to a fine, atomized mist to a powerful jet stream. Completely leak proof, even if overturned. Our Spray-Pro Sprayers are also available in a chemical resistant model (902PW9).



[A]

916CN / 922B / 924B / 932CG



[B]

3303BLWH



[C] 902BW7 / 902WW7 / 902RW7

Brand	Item #	Item	Size	Case Pack	Case Weight	Case Cubic Ft.	Stock Item
Continental	916CN	Center Neck	16 oz.	200	18.00 lbs.	8.000	✓
Continental	922B	Off-Set Neck	22 oz.	100	10.00 lbs.	1.000	✓
Continental	924B	Center Neck	24 oz.	100	13.00 lbs.	6.000	✓
Continental	932CG	Off-Set Neck	32 oz.	100	16.00 lbs.	7.000	✓
Continental	3303BLWH	High Output	9 3/4"	100	17.00 lbs.	2.000	✓
Continental	3303RDWH	High Output	9 3/4"	100	17.00 lbs.	2.000	✓
Continental	902BW7	Spray-Pro	8"	200	18.00 lbs.	2.040	✓
Continental	902WW7	Spray-Pro	8"	200	18.00 lbs.	2.040	✓
Continental	902RW7	Spray-Pro	8"	200	18.00 lbs.	2.040	✓
Continental	902WW9	Spray-Pro	9 3/4"	200	18.00 lbs.	2.040	✓
Continental	902RW9	Spray-Pro	9 3/4"	200	18.00 lbs.	2.040	✓
Continental	902BW9	Spray-Pro	9 3/4"	200	18.00 lbs.	2.040	✓
Continental	902PW9	Spray-Pro	9 3/4"	200	18.00 lbs.	2.040	✓

TANK SPRAYERS

[D] HUSKEE® TANK SPRAYER

Ideal for floor maintenance, pest control, masonry cleaning, wood preservative and general maintenance. The remarkable nozzle adjusts from a fine spray to a powerful jet stream to shoot contents up to 30' away. The furnished poly spray attachment rotates 360° with a polymer shut-off valve with lock-on and lock-off feature.

Brand	Item #	Total Capacity	Usable Capacity	Case Pack	Case Weight	Case Cubic Ft.	Stock Item
Continental	952	2 gal.	1.5 gal.	1	4.53 lbs.	0.800	✓
Continental	953	3 gal.	2.5 gal.	1	5.04 lbs.	0.950	✓



[D]

953

DRUM PUMPS

[A] PLASTIC SIPHON DRUM PUMP

Fits 55 gallon drums with a 1 1/2" or 2" openings. Five gallon per minute flow rate. Polyethylene construction resists acid, caustic, alkaline, light oils, waxes, cleaners and insecticides.

[B] SELF-PRIMING NICKEL PLATED PUMP

Fits 15, 30 and 55 gallon drums with a 1 1/2" or 2" openings. Dispenses 22 ounces per stroke. Nickel plated pump resists chemical action of non-corrosive liquids.

[C] ADJUSTABLE PLASTIC DRUM PUMP

Fits five to 30 gallon drums with a 1/2" or 2" openings. Adjust to dispense two, four, six or eight ounces per stroke. Chemical and acid resistant design.

[D] PUMP DISPENSER

The unique threaded body disassembles quickly for sanitary cleaning. The body and head are polypropylene for maximum chemical compatibility. Use with cleaners, waxes, food products, cooking oils, hand soap, shampoo and germicidal detergents. Standard with Poly Flap Valve (HDPE), made from FDA and USDA approved materials. The 10BC (38mm) Buttress Cap allows use of the 10HL on a five gallon pail with a flexi-spout.

Brand	Item #	Item	Dip Tube Length	Case Pack	Case Weight	Case Cubic Ft.	Stock Item
Continental	440	Plastic Siphon	---	12	10.20 lbs.	2.160	✓
Continental	495	Self-Priming	---	6	28.98 lbs.	2.100	✓
Continental	330	Adjustable	---	12	10.56 lbs.	1.320	✓
Continental	10H	Ounce Pump	---	144	24.48 lbs.	3.790	✓
Continental	10HL	Ounce Pump	---	144	24.48 lbs.	3.790	✓
Continental	10BC	Buttress Cap	---	144	5.76 lbs.	1.440	✓

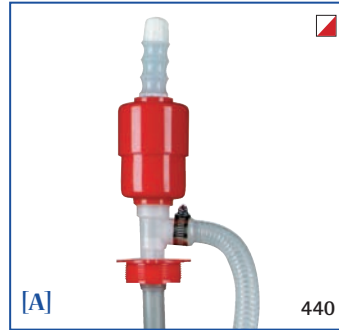

WINDOW SQUEEGEES

The solution to window cleaning is as clear as glass with our complete line of equipment and accessories. Our line includes brass, stainless steel and ABS plastic squeegees... and more!

BRASS SQUEEGEES

[E] BRASS SQUEEGEE COMPLETE

Traditional high quality brass window squeegee complete, fitted with soft rubber blade for a streak-free finish.

Brand	Item #	Size	Case Pack	Case Weight	Case Cubic Ft.	Stock Item
Continental	2510-22	10"	10	4.80 lbs.	0.170	✓
Continental	2512-22	12"	10	5.20 lbs.	0.170	✓
Continental	2514-22	14"	10	5.60 lbs.	0.170	✓
Continental	2516-22	16"	10	5.90 lbs.	0.170	✓
Continental	2518-22	18"	10	5.30 lbs.	0.170	✓



STAINLESS STEEL CLASSIC SQUEEGEES

[A] STAINLESS STEEL SQUEEGEE COMPLETE

This professional window squeegee is made from stainless steel, is rust-free and is fitted with a standard hard rubber blade.

Brand	Item #	Size	Case Pack	Case Weight	Case Cubic Ft.	Stock Item
Continental	2510-11	10"	10	4.50 lbs.	0.170	✓
Continental	2512-11	12"	10	4.80 lbs.	0.170	✓
Continental	2514-11	14"	10	5.10 lbs.	0.170	✓
Continental	2518-11	18"	10	5.70 lbs.	0.170	✓



PLASTIC SQUEEGEES

[B] PLASTIC SQUEEGEE COMPLETE

Lightweight and durable ABS plastic handle with aluminum channel fitted with a standard soft rubber blade.

Brand	Item #	Size	Case Pack	Case Weight	Case Cubic Ft.	Stock Item
Continental	2470	8"	12	3.36 lbs.	0.600	✓
Continental	2472	12"	12	3.84 lbs.	0.600	✓
Continental	2473	14"	12	3.96 lbs.	0.720	✓
Continental	2475	18"	12	4.20 lbs.	0.840	✓



REPLACEMENT BLADES

[C] REPLACEMENT RUBBER BLADE

Ideal for all window squeegees.

Brand	Item #	Size	Case Pack	Case Weight	Case Cubic Ft.	Stock Item
Continental	2510-3	10"	50	2.80 lbs.	0.100	✓
Continental	2512-3	12"	50	2.50 lbs.	0.150	✓
Continental	2514-3	14"	50	3.00 lbs.	0.150	✓
Continental	2516-3	16"	50	3.00 lbs.	0.150	✓
Continental	2518-3	18"	50	3.50 lbs.	0.150	✓



WINDOW WASHERS COMPLETE

[D] PLASTIC MICROTIGER COMPLETE

All plastic T-handle with Microtiger washer sleeve. The Microtiger sleeve is microfiber with the addition of a nylon abrasive material for thorough cleaning.

Brand	Item #	Size	Case Pack	Case Weight	Case Cubic Ft.	Stock Item
Continental	2514-99T	14"	20	10.80 lbs.	1.690	✓
Continental	2518-99T	18"	20	12.60 lbs.	1.690	✓



SCRAPERS AND BLADES

[A] SCRAPER WITH PLASTIC HANDLE

The scraper line was designed for glass windows, doors and floors. All come with blade protector cover. 2556 may be used with our telescopic poles.

[B] SPECIAL BLADE FOR SCRAPER

Dispenser with ten blades.

Brand	Item #	Size	Case Pack	Case Weight	Case Cubic Ft.	Stock Item
Continental	2556	4" x 8"	10	3.10 lbs.	0.300	✓
Continental	2563	4" x 12"	10	8.60 lbs.	0.500	✓
Continental	2562	4" x 48"	10	8.50 lbs.	1.100	✓
Continental	2557	4"	50	0.55 lbs.	0.010	✓



RECEPTACLES, LIDS & ACCESSORIES

Simply put, Continental's line of indoor and outdoor receptacles is the best! Best in choice, functionality and value. Add our dollies and accessories to maximize performance and add even more value!

[C] HUSKEE® ROUND

The industry standard! Molded with seamless construction, the Huskee® is a strong, long lasting receptacle that is used everywhere. From food prep to foundries, from refuse to bio- hazard waste, the Huskee® keeps on working. Stackable with lid on, nestable with lid off. For Huskee® Accessories, see pages 94-96.

Brand	Item #	Size	Color	Case Pack	Case Weight	Case Cu. Ft.	Stock Item
Continental	*1001GY	10 gal.	Grey	6	19.14 lbs.	5.400	✓
Continental	*1001WH	10 gal.	White	6	19.14 lbs.	5.400	✓
Continental	*2000BL	20 gal.	Blue	6	38.76 lbs.	11.220	✓
Continental	*2000GY	20 gal.	Grey	6	38.76 lbs.	11.220	✓
Continental	*2000WH	20 gal.	White	6	38.76 lbs.	11.220	✓
Continental	*3200BL	32 gal.	Blue	6	57.60 lbs.	16.690	✓
Continental	*3200GN	32 gal.	Green	6	57.60 lbs.	16.690	✓
Continental	*3200GY	32 gal.	Grey	6	57.60 lbs.	16.690	✓
Continental	*3200GYBP	32 gal.	Grey	48 / Bulk	423.84 lbs.	105.120	✓
Continental	*3200RD	32 gal.	Red	6	57.60 lbs.	16.690	✓
Continental	*3200WH	32 gal.	White	6	57.60 lbs.	16.690	✓
Continental	*3200YW	32 gal.	Yellow	6	57.60 lbs.	16.690	✓

* Items are NSF® Listed

Huskee® Round Chart continues on the following page - includes 44 and 55 gallon sizes.



More Structural Ribs
for added Durability!



Built-in Huskee® Bag Cinch eliminates the need to tie knots in the polyliner to keep it secure around the receptacle rim! Available on 32, 44 and 55 gallon sizes.



Available in a Recycle model, see page 108 for details.

RECEPTACLES, LIDS & ACCESSORIES

[A] HUSKEE® ROUND (continued)

The industry standard!

Brand	Item #	Size	Color	Case Pack	Case Weight	Case Cu. Ft.	Stock Item
Continental	*4444BL	44 gal.	Blue	4	50.48 lbs.	21.040	✓
Continental	*4444GN	44 gal.	Green	4	50.48 lbs.	21.040	✓
Continental	*4444GY	44 gal.	Grey	4	50.48 lbs.	21.040	✓
Continental	*4444GY BP	44 gal.	Grey	48 / Bulk	392.32 lbs.	125.120	✓
Continental	*4444RD	44 gal.	Red	4	50.48 lbs.	21.040	✓
Continental	*4444WH	44 gal.	White	4	50.48 lbs.	21.040	✓
Continental	*4444YW	44 gal.	Yellow	4	50.48 lbs.	21.040	✓
Continental	5500GY	55 gal.	Grey	3	52.44 lbs.	21.720	✓

* Items are NSF® Listed

Huskee® Round Chart on the previous page includes 10, 20 and 32 gallon sizes.

[B] HUSKEE® ROUND LIDS

Brand	Item #	Fits	Color	Case Pack	Case Weight	Case Cu. Ft.	Stock Item
Continental	*1002GY	10 gal.	Grey	6	5.40 lbs.	1.200	✓
Continental	*1002WH	10 gal.	White	6	5.40 lbs.	1.200	✓
Continental	*2001GY	20 gal.	Grey	6	10.20 lbs.	2.280	✓
Continental	*2001WH	20 gal.	White	6	10.20 lbs.	2.280	✓
Continental	*3201GY	32 gal.	Grey	6	13.80 lbs.	3.240	✓
Continental	*3201RD	32 gal.	Red	6	13.80 lbs.	3.240	✓
Continental	*3201WH	32 gal.	White	6	13.80 lbs.	3.240	✓
Continental	*3201YW	32 gal.	Yellow	6	13.80 lbs.	3.240	✓
Continental	*4445GY	44 gal.	Grey	4	11.24 lbs.	2.560	✓
Continental	*4445RD	44 gal.	Red	4	11.24 lbs.	2.560	✓
Continental	*4445WH	44 gal.	White	4	11.24 lbs.	2.560	✓
Continental	*4445YW	44 gal.	Yellow	4	11.24 lbs.	2.560	✓
Continental	5501GY	55 gal.	Grey	3	12.75 lbs.	3.840	✓

* Items are NSF® Listed

[C] "INEDIBLE" HUSKEE® ROUND

32 and 44 gallon Huskee® pre-printed with "Inedible." Lettering is 3" high.

Brand	Item #	Size	Color	Case Pack	Case Weight	Case Cu. Ft.	Stock Item
Continental	*3200GYINED	32 gal.	Grey	48 / Bulk	57.60 lbs.	16.690	✓
Continental	*4444GYINED	44 gal.	Grey	48 / Bulk	57.60 lbs.	16.690	✓

* Items are NSF® Listed



Available in a Recycle model, see page 108 for details.



RECEPTACLES, LIDS & ACCESSORIES

[A] SUPERKAN®

The Huskee® SuperKan® Material Handler is compatible with the Huskee® Round Dolly, Caddy Bag, Maid Caddy, 32 or 44 gallon Huskee® Round Lids and the Huskee® Dome and Funnel Tops.

Brand	Item #	Size	Color	Case Pack	Case Weight	Case Cu. Ft.	Stock Item
Continental	*4442BK	44 gal.	Black	4	54.00 lbs.	25.010	✓

* NSF® Listed



[B] HUSKEE® BACKSAVER

This receptacle is everything the standard Huskee® Round is, and more! Internal vent ribs, which break the vacuum caused when removing a poly liner, were incorporated into the design, making it the easiest receptacle to use. Compatible with the Huskee® Round Dolly, Caddy Bag, Maid Caddy, 32 or 44 gallon Huskee® Round Lids and the Huskee® Dome and Funnel Tops.

Brand	Item #	Size	Color	Case Pack	Case Weight	Case Cu. Ft.	Stock Item
Continental	3210GY	32 gal.	Grey	4	35.50 lbs.	18.407	✓
Continental	4410GY	44 gal.	Grey	3	38.75 lbs.	20.972	✓



Built-in Huskee® Bag Cinch eliminates the need to tie knots in the polyliner to keep it secured around the receptacle rim!



[C] HUSKEE® MAID CADDY

This handy Huskee® accessory has a convenient handle to raise and carry or collapse out of the way. Fits on Round or Square Huskee® receptacles and the 50 gallon Tilt-N-Wheel®.

Brand	Item #	Color	Case Pack	Case Weight	Case Cubic Ft.	Stock Item
Continental	3155	Grey	4	12.50 lbs.	2.130	✓



SAFER BECAUSE OF VENTS!

The National Safety Council puts the total cost of work injuries at \$121 billion annually, and the cost per disabling injury at \$26,000, and growing. Back injuries are 20% of all claims. The Huskee® BackSaver uses internal, ergonomic lift vents to break the vacuum created when removing a polyliner, resulting in reduced effort and reduced risk of back injury.

[D] HUSKEE® CADDY BAG

Add this adjustable nine pocket caddy bag to a Round or Square Huskee® on a dolly for a durable cleaning system that is ready to make the rounds. Made of nylon reinforced PVC for years of reliable service.

Brand	Item #	Color	Case Pack	Case Weight	Case Cubic Ft.	Stock Item
Continental	3175	Yellow	6	6.92 lbs.	2.200	✓



RECEPTACLES, LIDS & ACCESSORIES

[A] HUSKEE® ROUND DOLLY

The twist-on, twist-off Round Dolly converts a stationary Huskee® into a mobile hard working tool. It fits the 20, 32, 44 and 55 gallon Huskee® Round and features five, 3" non-marking swivel casters.

Brand	Item #	Color	Case Pack	Case Weight	Case Cubic Ft.	Stock Item
Continental	3255	Black	2	17.06 lbs.	1.840	✓



[B] HUSKEE® DOME TOP

The economic answer wherever large refuse collection in public places is required. Conveniently sized to fit our 32, 44 and 55 gallon Huskee® receptacles. The 44 gallon model Dome Top also fits 55 gallon metal drums. The wide rim and tight fitting door with rain deflector keeps debris and odors in and rain and pests out.

Brand	Item #	Fits	Color	Case Pack	Case Weight	Case Cu. Ft.	Stock Item
Continental	3232BL	32 gal.	Blue	2	12.84 lbs.	7.870	✓
Continental	3232BK	32 gal.	Black	2	12.84 lbs.	7.870	✓
Continental	3232GY	32 gal.	Grey	2	12.84 lbs.	7.870	✓
Continental	3232RD	32 gal.	Red	2	12.84 lbs.	7.870	✓
Continental	4456BL	44 gal.	Blue	2	14.72 lbs.	10.070	✓
Continental	4456BK	44 gal.	Black	2	14.72 lbs.	10.070	✓
Continental	4456GY	44 gal.	Grey	2	14.72 lbs.	10.070	✓
Continental	4456RD	44 gal.	Red	2	14.72 lbs.	10.070	✓
Continental	5550BL	55 gal.	Blue	2	19.36 lbs.	13.030	✓
Continental	5550BK	55 gal.	Black	2	19.36 lbs.	13.030	✓
Continental	5550GY	55 gal.	Grey	2	19.36 lbs.	13.030	✓
Continental	5550RD	55 gal.	Red	2	19.36 lbs.	13.030	✓



[C] HUSKEE® TIP TOP LID

Gravity, hands-free opening encourages use and automatically closes to hide trash. No metal parts to rust or break.

Brand	Item #	Fits	Color	Case Pack	Case Weight	Case Cu. Ft.	Stock Item
Continental	3231	32 gal.	Grey	6	25.92 lbs.	5.280	✓



[D] HUSKEE® FUNNEL TOP

Designed for high volume applications, this open top funnel lid handles indoor applications ranging from food service to industrial.

Brand	Item #	Fits	Color	Case Pack	Case Weight	Case Cu. Ft.	Stock Item
Continental	3233GY	32 gal.	Grey	4	12.20 lbs.	2.640	✓
Continental	4457GY	44 gal.	Grey	4	14.04 lbs.	3.170	✓



RECEPTACLES, LIDS & ACCESSORIES

[A] HUSKEE® SQUARE

These containers are ideal for food handling, hospital, bio-hazard, commercial refuse and recycle collection. All Square Huskee® receptacles are stackable with lids and nestable without lids. Lids snap and lock in place keeping refuse and odor in, animals and pests out. This container is easy to clean and has a molded in bottom grip for comfortable lifting. Heavy-duty, non-slip handles have drain holes.

Brand	Item #	Size	Color	Case Pack	Case Weight	Case Cu. Ft.	Stock Item
Continental	2800GY	32 gal.	Grey	6	59.64 lbs.	17.220	✓
Continental	*2800RD	32 gal.	Red	6	59.64 lbs.	17.220	✓
Continental	2800WH	32 gal.	White	6	59.64 lbs.	17.220	✓
Continental	4000GY	48 gal.	Grey	4	59.12 lbs.	20.040	✓
Continental	4000RD	48 gal.	Red	4	59.12 lbs.	20.040	✓
Continental	5000GY	55 gal.	Grey	4	73.56 lbs.	25.640	✓

* Items are UN / DOT certified for the transport of dangerous goods



[A]



Available in a Recycle model, see page 108 for details.

[B] HUSKEE® SQUARE LIDS

Brand	Item #	Fits	Color	Case Pack	Case Weight	Case Cu. Ft.	Stock Item
Continental	2801GY	32 gal.	Grey	6	17.70 lbs.	3.060	✓
Continental	*2801RD	32 gal.	Red	6	17.70 lbs.	3.060	✓
Continental	2801WH	32 gal.	White	6	17.70 lbs.	3.060	✓
Continental	4001GY	48 gal.	Grey	4	13.40 lbs.	2.400	✓
Continental	4001RD	48 gal.	Red	4	13.40 lbs.	2.400	✓
Continental	5001GY	55 gal.	Grey	4	15.48 lbs.	2.680	✓

* Items are UN / DOT certified for the transport of dangerous goods



[B]

[C] HUSKEE® SQUARE LOCK LID

Offers extra tight fit on 32 gallon Square Huskee®. Ideal for bio-medical waste hauling. Four handle design locks on all edges of the Huskee® for secure locking fit.

Brand	Item #	Color	Case Pack	Case Weight	Case Cubic Ft.	Stock Item
Continental	*2811RD	Red	6	17.70 lbs.	3.060	

* Custom item - call for details.



[C]

[D] HUSKEE® SQUARE DOME TOP LID

Economical answer wherever high volume applications are required. This new Dome Top fits the 55 gallon Square Huskee® Receptacles.

Brand	Item #	Fits	Color	Case Pack	Case Weight	Case Cu. Ft.	Stock Item
Continental	5556GY	55 gal.	Grey	1	13.30 lbs.	5.900	✓



[D]

[E] HUSKEE® SQUARE DOLLY

The twist-on, twist-off Square Dolly converts a stationary Huskee® into a mobile, hard-working tool. It fits all Square Huskee® Receptacles and features four 3" non-marking, swivel casters.

Brand	Item #	Color	Case Pack	Case Weight	Case Cubic Ft.	Stock Item
Continental	2803	Black	2	15.44 lbs.	2.680	✓



[E]

RECEPTACLES, LIDS & ACCESSORIES

The Colossus® Receptacle is available with four openings, or with two spring loaded doors. Both versions are available as a 45 or 56 gallon receptacle, to meet any capacity requirement. Dual vinyl-coated cable lid stays hold the lid in a vertical position for safe, easy emptying, and help eliminate tipping of the base. Heavy-duty poly liner retainer straps allow the user to secure a poly liner within the container for a clean, professional appearance.

[A] COLOSSUS®

The Colossus® Receptacle with four openings has two large front openings (17½" x 9½" high) and two large side openings (13⅜" x 8½" high), which can easily accommodate bulky debris like pizza boxes, 32 ounce cups and food service trays – this unit is truly designed for high volume applications! The contoured lid's top surface prevents accumulation of debris and water while providing a unique and visually appealing style.

The Colossus® Receptacle with spring-loaded doors is Factory Mutual Approved, because of its doors' tight fit to the lid and the lid fit to the base. The heavy-duty door springs keep doors closed tight to keep odors in and pests out.

 Available in a Recycle model, see page 109 for details.

Brand	Item #	Description	Size	Color	Case Pack	Case Weight	Case Cu. Ft.	Stock Item
Continental	*6452BE	Two Doors	45 gal.	Beige	1	41.00 lbs.	18.760	✓
Continental	*6452BN	Two Doors	45 gal.	Brown	1	41.00 lbs.	18.760	✓
Continental	6454BE	Four Openings	45 gal.	Beige	1	37.00 lbs.	18.760	✓
Continental	6454BN	Four Openings	45 gal.	Brown	1	37.00 lbs.	18.760	✓
Continental	*6562BE	Two Doors	56 gal.	Beige	1	58.00 lbs.	21.010	✓
Continental	*6562BN	Two Doors	56 gal.	Brown	1	58.00 lbs.	21.010	✓
Continental	6564BE	Four Openings	56 gal.	Beige	1	44.00 lbs.	21.010	✓
Continental	6564BN	Four Openings	56 gal.	Brown	1	44.00 lbs.	21.010	✓

* Items are Fire Resistant and FM Approved

Ash Tray Top and Tray Top easily attach to any Colossus® Receptacle. Rigid plastic liners have handle holes for easy lifting and dumping. Weighted Base can be filled with sand or gravel, adding approximately 17 lbs. of weight for stability when unit is used in outdoor applications.

[B] COLOSSUS® WEIGHTED BASE

Weighted Base can be filled with sand or gravel, adding approximately 17 pounds of weight for stability when unit is used outdoors.

[C] COLOSSUS® TRAY TOP

Optional Tray Top is designed to accommodate food service trays up to 12.5" x 17.5"

[D] COLOSSUS® ASH TRAY TOP

[E] COLOSSUS® RIGID PLASTIC LINER



DERMA-TEK® FINISH

Heavy-duty polyliner retainer straps

Dual Vinyl-coated cable lid stays

FM APPROVED FIRE-RESISTANT

Colossus® receptacles with two spring-loaded doors only

[A] 6452BN / 6564BE



Brand	Item #	Description	Size	Color	Case Pack	Case Weight	Case Cubic Ft.	Stock Item
Continental	6456BK	Weighted Base	15¾" x 13¼" x 3"	Black	1	3.20 lbs.	0.420	✓
Continental	6557BK	Tray Top	18½" x 14⅝" x 2⅜"	Black	1	2.00 lbs.	0.430	✓
Continental	6458BK	Ash Tray Top	13½" x 13¼" x 2⅝"	Black	1	1.50 lbs.	0.340	✓
Continental	6451BK	Rigid Liner / 45 gallon	21½" x 20½" x 24¼"	Black	1	12.20 lbs.	6.660	✓
Continental	6561BK	Rigid Liner / 56 gallon	21½" x 20½" x 29½"	Black	1	13.68 lbs.	7.830	✓

RECEPTACLES, LIDS & ACCESSORIES

[A] KING KAN®

The King Kan® won't dent, crack, chip or warp even under the roughest conditions. Add optional 3" non-marking casters to the 35/50 gallon King Kan® for increased mobility. King Kan® lids feature two heavy-duty plated steel hinges, which eliminate awkward lifting, removing and repositioning of the lid. The lid sits tightly on the base to control odors, insects and pests.

Brand	Item #	Size	Color	Case Pack	Case Weight	Case Cubic Ft.	Stock Item
Continental	*5735BE	35 gal.	Beige	1	35.00 lbs.	7.720	✓
Continental	*5735BN	35 gal.	Brown	1	35.00 lbs.	7.720	✓
Continental	*5750BE	50 gal.	Beige	1	42.00 lbs.	9.970	✓
Continental	*5750BN	50 gal.	Brown	1	42.00 lbs.	9.970	✓
Continental	5765BN	65 gal.	Brown	1	65.63 lbs.	14.480	✓

* Items are FM Approved



[A]

5735BE / 5750BN

[B] RIGID PLASTIC LINER

Features two handle holes for easy removal.

[C] KING KAN® POLY BAG

54 gallon size.

[D] KING KAN® LEG KIT

Four pre-drilled, epoxy-coated steel legs are 2" high.



[B]

6451BK



[C]

1924



[D]

5766L

Brand	Item #	Description	Fits	Color	Case Pack	Case Weight	Case Cubic Ft.	Stock Item
Continental	6451BK	Rigid Plastic Liner	50 / 65 gallon sizes	Black	1	12.20 lbs.	6.670	✓
Continental	1924	Poly Bag, 54 gallon / 50" x 43"	65 gallon size	White	100	13.00 lbs.	0.560	✓
Continental	5766L	Leg Kit	All sizes	Black	1	2.70 lbs.	0.080	✓

[E] TILT-N-WHEEL®

These 50 gallon containers have a hinged double walled lid with standard 8" non-marking wheels.

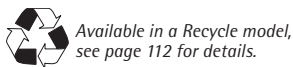

Brand	Item #	Size	Color	Case Pack	Case Weight	Case Cu. Ft.	Stock Item
Continental	5850BK	50 gal.	Black	2	56.00 lbs.	18.540	✓
Continental	5850YW	50 gal.	Yellow	2	56.00 lbs.	18.540	✓



[E]

5850BK

RECEPTACLES, LIDS & ACCESSORIES

[A] CORNER ROUND™

Fits into corners to utilize space. This durable plastic design will not chip, rust, crack, peel or fade. Its 21 gallon capacity and extra large opening make it ideal for school cafeterias, atriums, foyers, food courts, airport terminals, plazas, convention centers, etc. Choose between a securing bag rim type or a hooded domed top lid.

 Available in a Recycle model, see page 109 for details.

Brand	Item #	Style /Size	Color	Case Pack	Case Weight	Case Cu. Ft.	Stock Item
Continental	8324BE	Rim / 21 gal.	Beige	2	22.50 lbs.	6.340	✓
Continental	8324BK	Rim / 21 gal.	Black	2	35.00 lbs.	6.340	✓
Continental	8324BN	Rim / 21 gal.	Brown	2	42.00 lbs.	6.340	✓
Continental	8324GY	Rim / 21 gal.	Grey	2	42.00 lbs.	6.340	✓
Continental	8325BE	Dome / 21 gal.	Beige	1	14.00 lbs.	4.810	✓
Continental	8325BK	Dome / 21 gal.	Black	1	14.00 lbs.	4.810	✓
Continental	8325BN	Dome / 21 gal.	Brown	1	14.00 lbs.	4.810	✓
Continental	8325GY	Dome / 21 gal.	Grey	1	14.00 lbs.	4.810	✓



[B] CORNER ROUND™ DOLLY

This black, powder-coated steel Dolly has four 3", non-marking, all swivel casters. It turns Corner Round Receptacles into a mobile waste collection system. Sturdy handle makes moving the unit from place to place a breeze.

Brand	Item #	Color	Case Pack	Case Weight	Case Cubic Ft.	Stock Item
Continental	8325-D	Black	1	21.30 lbs.	5.160	✓



[C] FLAT TOP & ASH TOP

These receptacles have dual self-closing doors to keep debris and odor inside, pests out. The two door design encourages use. Removable top allows easy access with no clumsy straps. Unit can be positioned for access to both sides. Factory Mutual fire resistant design contains and extinguishes fires.

Brand	Item #	Size	Color	Case Pack	Case Weight	Case Cu. Ft.	Stock Item
Continental	1432BE	24 gal.	Beige	1	23.50 lbs.	7.970	✓
Continental	1432BK	24 gal.	Black	1	23.50 lbs.	7.970	✓
Continental	1432BN	24 gal.	Brown	1	23.50 lbs.	7.970	✓
Continental	1432GY	24 gal.	Grey	1	23.50 lbs.	7.970	✓
Continental	1435BE	24 gal.	Beige	1	23.50 lbs.	7.970	✓
Continental	1435BK	24 gal.	Black	1	23.50 lbs.	7.970	✓
Continental	1435BN	24 gal.	Brown	1	23.50 lbs.	7.970	✓
Continental	1435GY	24 gal.	Grey	1	23.50 lbs.	7.970	✓



RECEPTACLES, LIDS & ACCESSORIES

[A] FUNNEL TOP

This big mouth receptacle encourages use because of its appealing open, funnel top design. With absolutely no metal parts, these containers are safe for secure areas in hospitals or prison systems. They are available in color choices to compliment any decor. The unique "key-way" feature and shoulder design allow poly liners to be secured, hiding unsightly 'bag skirt'. Plus, the built-in lock ring secures Funnel Top from theft or high winds.

Brand	Item #	Size	Color	Case Pack	Case Weight	Case Cu. Ft.	Stock Item
Continental	1430BE	24 gal.	Beige	1	23.00 lbs.	6.520	✓
Continental	1430BK	24 gal.	Black	1	23.00 lbs.	6.520	✓
Continental	1430BN	24 gal.	Brown	1	23.00 lbs.	6.520	✓
Continental	1430GY	24 gal.	Grey	1	23.00 lbs.	6.520	✓



[B] ROUN'TOP™

With absolutely no metal parts, these containers are safe for secure areas in hospitals or prison systems. The Roun'Top™ is Factory Mutual Approved, designed to contain and extinguish a fire, assuring safety. Available in either 18 or 24 gallon sizes to fit any need. Removable top allows easy access. Unique "key-way" notch secures poly liners with no clumsy straps to snag liners. Weather-proof design allows outside use with confidence.

Brand	Item #	Liner	Capacity	Color	Case Pack	Case Weight	Case Cu. Ft.	Stock Item
Continental	1305BE	None	18 gal.	Beige	1	17.50 lbs.	5.520	✓
Continental	1305BK	None	18 gal.	Black	1	17.50 lbs.	5.520	✓
Continental	1305BN	None	18 gal.	Brown	1	17.50 lbs.	5.520	✓
Continental	1305GY	None	18 gal.	Grey	1	17.50 lbs.	5.520	✓
Continental	1307BE	Rigid Plastic	15 gal.	Beige	1	24.50 lbs.	5.520	✓
Continental	1307BK	Rigid Plastic	15 gal.	Black	1	24.50 lbs.	5.520	✓
Continental	1307BN	Rigid Plastic	15 gal.	Brown	1	24.50 lbs.	5.520	✓
Continental	1307GY	Rigid Plastic	15 gal.	Grey	1	24.50 lbs.	5.520	✓
Continental	1425BE	None	24 gal.	Beige	1	23.50 lbs.	7.970	✓
Continental	1425BK	None	24 gal.	Black	1	23.50 lbs.	7.970	✓
Continental	1425BN	None	24 gal.	Brown	1	23.50 lbs.	7.970	✓
Continental	1425GY	None	24 gal.	Grey	1	23.50 lbs.	7.970	✓
Continental	1427BE	Rigid Plastic	21 gal.	Beige	1	39.50 lbs.	7.970	✓
Continental	1427BK	Rigid Plastic	21 gal.	Black	1	39.50 lbs.	7.970	✓
Continental	1427BN	Rigid Plastic	21 gal.	Brown	1	39.50 lbs.	7.970	✓
Continental	1427GY	Rigid Plastic	21 gal.	Grey	1	39.50 lbs.	7.970	✓



RECEPTACLES, LIDS & ACCESSORIES

[A] DESIGN-LINE ROUN'TOP™

These receptacles have all the features of the standard Roun'Top™, but are now available in four granite finishes that provide the architectural appeal of a concrete or stone receptacle without the excessive weight or cost. Available in 18 or 24 gallon sizes to fit any need, Factory Mutual and CSFM Approved.

Brand	Item #	Size	Color	Case Pack	Case Weight	Case Cubic Ft.	Stock Item
Continental	1305BKS	18 gal.	Blackstone	1	17.50 lbs.	5.520	✓
Continental	1305BNS	18 gal.	Brownstone	1	17.50 lbs.	5.520	✓
Continental	1305GYS	18 gal.	Greystone	1	17.50 lbs.	5.520	✓
Continental	1305SDS	18 gal.	Sandstone	1	17.50 lbs.	5.520	✓
Continental	1425BKS	24 gal.	Blackstone	1	23.50 lbs.	7.970	✓
Continental	1425BNS	24 gal.	Brownstone	1	23.50 lbs.	7.970	✓
Continental	1425GYS	24 gal.	Greystone	1	23.50 lbs.	7.970	✓
Continental	1425SDS	24 gal.	Sandstone	1	23.50 lbs.	7.970	✓



The sturdy step pedal enables hands-free opening and closing of the receptacle lid, which makes it more sanitary. Aids in conforming to the OSHA regulation 1910.1030 known as "Occupational Exposure to Bloodborne Pathogens." Additionally, this line of receptacles is Factory Mutual (FM) and California State Fire Marshal (CSFM) approved for fire safety. Lid closes securely to receptacle base, which keeps odors contained. Lid attachment is covered on top so dirt does not collect in hinge. 23 gallon version has covered wheels for mobility and cleanliness. Unique "key-way" notch holds standard size poly liners.

[B] STEP-ON

Allows for convenient and hygienic disposal of waste. Step pedal provides hands-free use. Can be used with standard poly liners. 23 gallon version has wheels and wire frame for ease of mobility.

Brand	Item #	Size	Color	Case Pack	Case Weight	Case Cubic Ft.	Stock Item
Continental	8BE	8 gal.	Beige	1	7.20 lbs.	2.670	✓
Continental	8RD	8 gal.	Red	1	7.20 lbs.	2.670	✓
Continental	8WH	8 gal.	White	1	7.20 lbs.	2.670	✓
Continental	12BE	12 gal.	Beige	1	8.45 lbs.	3.710	✓
Continental	12RD	12 gal.	Red	1	8.45 lbs.	3.710	✓
Continental	12WH	12 gal.	White	1	8.45 lbs.	3.710	✓
Continental	18BE	18 gal.	Beige	1	11.00 lbs.	4.800	✓
Continental	18RD	18 gal.	Red	1	11.00 lbs.	4.800	✓
Continental	18WH	18 gal.	White	1	11.00 lbs.	4.800	✓
Continental	23BE	23 gal.	Beige	1	13.00 lbs.	5.920	✓
Continental	23RD	23 gal.	Red	1	13.00 lbs.	5.920	✓
Continental	23WH	23 gal.	White	1	13.00 lbs.	5.920	✓



[C] STEP-ON LINERS

Brand	Item #	Fits	Color	Case Pack	Case Weight	Case Cu. Ft.	Stock Item
Continental	15	18 gal.	Black	1	5.80 lbs.	3.000	✓
Continental	19	23 gal.	Black	1	7.60 lbs.	3.780	✓



RECEPTACLES, LIDS & ACCESSORIES

[A] WALL HUGGER™

Continental® Wall Huggers have a sleek and attractive design that holds either 16 or 23 gallons of waste, but protrudes less than one foot from the wall! The smooth, seamless design provides prolonged life and promotes easy cleaning. The line includes a version with built-in handles which provide ease of transport and a secure area to grasp when lifting and dumping. The addition of a Wall Hugger™ Drop Shot Lid helps to conceal waste while providing an inviting, enlarged opening for waste disposal. The 8 1/4" x 16 3/4" opening is the largest available in a Wall Hugger™ style receptacle!

Brand	Item #	Size / Style	Color	Case Pack	Case Weight	Case Cu. Ft.	Stock Item
Continental	8316BE	16 gal.	Beige	4	22.50 lbs.	5.050	✓
Continental	8316BK	16 gal.	Black	4	22.50 lbs.	5.050	✓
Continental	8316BN	16 gal.	Brown	4	22.50 lbs.	5.050	✓
Continental	8316GY	16 gal.	Grey	4	22.50 lbs.	5.050	✓
Continental	H8316BE	16 gal. w/handles	Beige	4	23.20 lbs.	5.680	✓
Continental	H8316BK	16 gal. w/handles	Black	4	23.20 lbs.	5.680	✓
Continental	H8316BN	16 gal. w/handles	Brown	4	23.20 lbs.	5.680	✓
Continental	H8316GY	16 gal. w/handles	Grey	4	23.20 lbs.	5.680	✓
Continental	8322BE	23 gal.	Beige	4	27.10 lbs.	6.200	✓
Continental	8322BK	23 gal.	Black	4	27.10 lbs.	6.200	✓
Continental	8322BN	23 gal.	Brown	4	27.10 lbs.	6.200	✓
Continental	8322GY	23 gal.	Grey	4	27.10 lbs.	6.200	✓
Continental	H8322BE	23 gal. w/handles	Beige	4	27.75 lbs.	7.150	✓
Continental	H8322BK	23 gal. w/handles	Black	4	27.75 lbs.	7.150	✓
Continental	H8322BN	23 gal. w/handles	Brown	4	27.75 lbs.	7.150	✓
Continental	H8322GY	23 gal. w/handles	Grey	4	27.75 lbs.	7.150	✓



[A]

(shown with 8320 Dolly and 7325 Drop Shot Lids)

Bag Cinch eliminates the need to tie knots in polyliners!

Recessed hand-hold area on bottom for easy lifting and emptying.

H8322BE / 8322BK

Available in a Recycle model, see page 110 for details.

[B] WALL HUGGER™ LIDS

Brand	Item #	Size / Style	Color	Case Pack	Case Weight	Case Cu. Ft.	Stock Item
Continental	7315GY	Lid w/ Handles	Grey	4	4.00 lbs.	1.000	✓
Continental	7325BE	Drop Shot Lid	Beige	4	12.50 lbs.	1.600	✓
Continental	7325BK	Drop Shot Lid	Brown	4	12.50 lbs.	1.600	✓
Continental	7325BN	Drop Shot Lid	Grey	4	12.50 lbs.	1.600	✓
Continental	7325GY	Drop Shot Lid	Beige	4	12.50 lbs.	1.600	✓
Continental	T7318BNBE	Push Door Lid	Brown/Beige	4	23.20 lbs.	5.680	✓
Continental	T7318GYGY	Push Door Lid	Grey/Grey	4	23.20 lbs.	5.680	✓



[B]

7325BK



[B]

7315GY



[B]

T7318BNBE

[C] WALL HUGGER™ DOLLY

The Wall Hugger™ line offers both Single and Quad-Collection Dollies. These attractive, black powder-coated steel Dollies have 3", non-marking, all swivel casters, enabling them to turn any CMC Wall Hugger™ or other receptacle into a mobile waste collection system.

Brand	Item #	Description	Color	Case Pack	Case Weight	Case Cu. Ft.	Stock Item
Continental	8320	Single Dolly	Black	2	19.50 lbs.	1.650	✓
Continental	8320-4	Quad Dolly	Black	1	21.40 lbs.	3.525	✓



[C]

8320



[C]

8320-4

RECEPTACLES, LIDS & ACCESSORIES

[A] HALF ROUND WALL HUGGER™

The Half Round completes the popular Wall Hugger™ Line. Its smaller footprint and impressive 21 gallon capacity is ideal for today's space-efficient workplace. The rounded front and sides allow use where other square or rectangular containers would interfere with traffic. The Half Rounds may be suspended off of the floor with our 8319 Mounting Bracket, below.

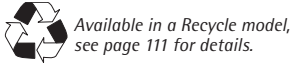

Available in a Recycle model, see page 111 for details.

Brand	Item #	Size	Color	Case Pack	Case Weight	Case Cubic Ft.	Stock Item
Continental	8321BE	21 gal.	Beige	2	15.20 lbs.	8.780	✓
Continental	8321GY	21 gal.	Grey	2	15.20 lbs.	8.780	✓



[B] WALL HUGGER™ MOUNTING BRACKET

Securely mount any Wall Hugger™ receptacle to the wall, suspending it above the floor. Elevating the receptacle allows easy cleaning of the floor under and around it. Use with 8321, 8322, H8322, 8316 and H8316 models.

Brand	Item #	Description	Color	Case Pack	Case Weight	Case Cu. Ft.	Stock Item
Continental	8319	Mounting Bracket	Grey	4	3.64 lbs.	0.040	✓



WASTE BASKETS

Indoor wastebaskets in every shape and size are ideal for schools, offices, healthcare and more. From UL classified products to economic desk side waste-baskets, these sleek and simple products provide solutions to meet all of your needs.

[C] SWINGLINE™

Square Swingline™ containers provide 25% more capacity which equates to labor and poly liner savings. The rolled rim provides strength and a convenient area to lift or pull. Reinforced base will take rough commercial use and they nest for easy storage. Compatible with the T1700 Tip Top, 1600 Swing Top or 1702 Drop Shot lids.

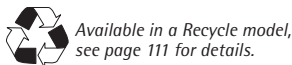

Available in a Recycle model, see page 111 for details.

Brand	Item #	Size	Color	Case Pack	Case Weight	Case Cu. Ft.	Stock Item
Continental	25BE	25 gal.	Beige	4	33.32 lbs.	8.440	✓
Continental	25BN	25 gal.	Brown	4	33.32 lbs.	8.440	✓
Continental	25GY	25 gal.	Grey	4	33.32 lbs.	8.440	✓
Continental	32BE	32 gal.	Beige	4	35.00 lbs.	9.280	✓
Continental	32BN	32 gal.	Brown	4	35.00 lbs.	9.280	✓
Continental	32GY	32 gal.	Grey	4	35.00 lbs.	9.280	✓



WASTEBASKETS

[A] DROP SHOT LID

Two door, center drop design with counter-weighted flippers opens easily and closes automatically. Large opening will accommodate up to a 16" pizza box, perfect for high volume areas.

[B] SWING TOP LID

Swing Top's opening makes refuse disposal easy. Peaked design is counter-weighted and automatically closes to hide trash. Sloped surfaces discourage cigarette and waste accumulation.

[C] TIP TOP LID

Gravity, hands-free opening encourages use and automatically closes to hide trash. No metal parts to rust or break.



Brand	Item #	Size	Color	Case Pack	Case Weight	Case Cu. Ft.	Stock Item
Continental	1702BE	Fits #25 & #32	Beige	4	17.76 lbs.	3.040	✓
Continental	1702BN	Fits #25 & #32	Brown	4	17.76 lbs.	3.040	✓
Continental	1702GY	Fits #25 & #32	Grey	4	17.76 lbs.	3.040	✓
Continental	T1600BE	Fits #25 & #32	Beige	4	11.88 lbs.	4.160	✓
Continental	T1600BN	Fits #25 & #32	Brown	4	11.88 lbs.	4.160	✓
Continental	T1600GY	Fits #25 & #32	Grey	4	11.88 lbs.	4.160	✓
Continental	T1700BE	Fits #25 & #32	Beige	4	11.80 lbs.	2.240	✓
Continental	T1700BN	Fits #25 & #32	Brown	4	11.80 lbs.	2.240	✓
Continental	T1700GY	Fits #25 & #32	Grey	4	11.80 lbs.	2.240	✓
Continental	T1700WH	Fits #25 & #32	White	4	11.80 lbs.	2.240	✓

[D] UL CLASSIFIED RECTANGULAR WASTEBASKET

Required baskets for healthcare and preferred elsewhere for the extra measure of fire safety. Non-metallic wastepaper container, classified by Underwriters Laboratories, Inc., only as to contain burning paper without melting or contributing fuel to the container contents.

Brand	Item #	Size	Color	Case Pack	Case Weight	Case Cu. Ft.	Stock Item
Continental	2907SD	7 qt.	Sand	6	13.56 lbs.	0.780	✓
Continental	2914BK	14 qt.	Black	6	24.48 lbs.	1.320	✓
Continental	2914SD	14 qt.	Sand	6	24.48 lbs.	1.320	✓
Continental	2927BK	27 ⁵ / ₈ qt.	Black	6	40.32 lbs.	2.730	✓
Continental	2927BN	27 ⁵ / ₈ qt.	Brown	6	40.32 lbs.	2.730	✓
Continental	2927SD	27 ⁵ / ₈ qt.	Sand	6	40.32 lbs.	2.730	✓



WASTEBASKETS

[A] STEELINE™

Steeline™ Wastebaskets are built for strength and beauty, exceeding industry standards for durability and performance. Fire safe steel adds an additional dimension of safety for protection against fire escalating or spreading. The rolled wire rim, double lock seams, embossed side panels and heavier gauge metal provide extra strength and superior dent resistance. The polyester powder coating process prevents scratches, chipping and rust. With the recessed bottom and metal construction, these containers will not burn or transfer heat to the floor.

Brand	Item #	Size	Color	Case Pack	Case Weight	Case Cu. Ft.	Stock Item
Continental	71NBK	26 qt.	Black	6	22.00 lbs.	2.380	✓
Continental	71NBN	26 qt.	Brown	6	22.00 lbs.	2.380	✓
Continental	71NGY	26 qt.	Grey	6	22.00 lbs.	2.380	✓
Continental	72NBE	49 qt.	Beige	3	20.00 lbs.	4.010	✓
Continental	72NGY	49 qt.	Grey	3	20.00 lbs.	4.010	✓
Continental	75NBE	80 qt.	Beige	3	28.00 lbs.	5.330	✓
Continental	75NGY	80 qt.	Grey	3	28.00 lbs.	5.330	✓



[B] COMMERCIAL PLASTIC WASTEBASKET

The low profile and sleek, attractive design of these wastebaskets make them the right choice for a variety of applications ranging from classroom, office, commercial or institutional use.

Brand	Item #	Size	Color	Case Pack	Case Weight	Case Cu. Ft.	Stock Item
Continental	1358BE	13 ⁵ / ₈ qt. Rectangle	Beige	12	15.00 lbs.	1.680	✓
Continental	1358BK	13 ⁵ / ₈ qt. Rectangle	Black	12	15.00 lbs.	1.680	✓
Continental	1358BN	13 ⁵ / ₈ qt. Rectangle	Brown	12	15.00 lbs.	1.680	✓
Continental	1358GN	13 ⁵ / ₈ qt. Rectangle	Green	12	15.00 lbs.	1.680	✓
Continental	1358GY	13 ⁵ / ₈ qt. Rectangle	Grey	12	15.00 lbs.	1.680	✓
Continental	2818BE	28 ¹ / ₈ qt. Rectangle	Beige	12	27.00 lbs.	2.880	✓
Continental	2818BK	28 ¹ / ₈ qt. Rectangle	Black	12	27.00 lbs.	2.880	✓
Continental	2818BN	28 ¹ / ₈ qt. Rectangle	Brown	12	27.00 lbs.	2.880	✓
Continental	2818GN	28 ¹ / ₈ qt. Rectangle	Green	12	27.00 lbs.	2.880	✓
Continental	2818GY	28 ¹ / ₈ qt. Rectangle	Grey	12	27.00 lbs.	2.880	✓
Continental	4114BE	41 ¹ / ₈ qt. Rectangle	Beige	12	35.16 lbs.	3.480	✓
Continental	4114BK	41 ¹ / ₈ qt. Rectangle	Black	12	35.16 lbs.	3.480	✓
Continental	4114BN	41 ¹ / ₈ qt. Rectangle	Brown	12	35.16 lbs.	3.480	✓
Continental	4114GN	41 ¹ / ₈ qt. Rectangle	Green	12	35.16 lbs.	3.480	✓
Continental	4114GY	41 ¹ / ₈ qt. Rectangle	Grey	12	35.16 lbs.	3.480	✓
Continental	4438BE	43 ³ / ₈ qt. Round	Beige	6	15.00 lbs.	3.900	✓
Continental	4438GY	43 ³ / ₈ qt. Round	Grey	6	15.00 lbs.	3.900	✓



Available in a Recycle model, see page 111 for details.

SMOKING RECEPTACLES

As the need for smoke-free environments grows, so does the demand for Continental's smoking receptacles. Our line of smoking receptacles offers convenience and value to any business owner. The outdoor receptacles hold over 3000 extinguished cigarettes, while allowing minimal smoke exit and minimum water entry. We also offer indoor floor urns and wall mount receptacles.

[A] SMOKING RECEPTACLE

These smoking receptacles are geared toward outdoor use. Galvanized inner liner included.

Brand	Item #	Description	Color	Case Pack	Case Weight	Case Cu. Ft.	Stock Item
Continental	887BE	Classic	Beige	1	8.40 lbs.	3.130	✓
Continental	887BK	Classic	Black	1	8.40 lbs.	3.130	✓
Continental	887GY	Classic	Grey	1	8.40 lbs.	3.130	✓
Continental	889	Cactus	Green/Tan	1	9.16 lbs.	3.130	✓
Continental	892	Lighthouse	Bk/Rd/Wh	1	9.16 lbs.	3.130	✓



[B] ASH RECEPTACLE

These satin chrome ash receptacles mount to the wall. Push button drops debris into liner. Liner included.

Brand	Item #	Size	Color	Case Pack	Case Weight	Case Cu. Ft.	Stock Item
Continental	132	3 ¹³ / ₁₆ " x 2 ⁵ / ₁₆ " x 4"	Chrome	12	11.04 lbs.	0.840	✓
Continental	650	8 ¹³ / ₁₆ " x 7 ¹ / ₂ " x 9 ⁹ / ₁₆ "	Chrome	6	27.72 lbs.	3.720	✓



[C] FLOOR SAND URN

These rugged sand urns are manufactured of structural plastic and include a chrome plated ashtray top. Sand Urns are made to color coordinate with the RounTop™ receptacle line.

[D] ASH & TRASH RECEPTACLE

Combination sand urn and waste receptacle. This unit is made of structural plastic and includes a galvanized metal liner. Provides an added measure of fire safety when placed together with RounTop™, Funnel Tops and Flat Tops.

Brand	Item #	Size	Color	Case Pack	Case Weight	Case Cu. Ft.	Stock Item
Continental	888BK	20" x 10" dia.	Black	1	7.31 lbs.	1.280	✓
Continental	888BN	20" x 10" dia.	Brown	1	7.31 lbs.	1.280	✓
Continental	885BK	23 ¹³ / ₁₆ " x 10" dia.	Black	1	12.50 lbs.	2.130	✓



[E] COLOSSUS® ASH TRAY TOP

The Ash Tray Top easily attaches to any Colossus® Receptacle without the aid of power tools. Includes four self-tapping screws and a replaceable, chrome-plated ash tray insert.

Brand	Item #	Size	Color	Case Pack	Case Weight	Case Cu. Ft.	Stock Item
Continental	6458BK	13 ¹ / ₂ " x 13 ³ / ₄ " x 2 ⁵ / ₈ "	Black	1	1.50 lbs.	0.340	✓



A complete line of Colossus® Receptacles can be found on page 98



RECYCLING

Continental® has a wide variety of recycling receptacles that promote and enhance a comprehensive recycling program. Made from recycled resins, our products are highly functional and durable. Innovative, sleek and attractive designs encourage users to support recycling programs.

[A] HUSKEE® ROUND **EARTHTONE™**

Molded of engineered resins with seamless construction, the Huskee® is a strong, long lasting receptacle ideal for recycling applications. Optional Recycle Lid has center hole and permanent "Cans Only" imprint to encourage use.

Brand	Item #	Size	Color	Case Pack	Case Weight	Case Cu. Ft.	Stock Item
Continental	2000-1	20 gal.	Blue	6	38.76 lbs.	10.920	✓
Continental	3200-1	32 gal.	Blue	6	57.60 lbs.	16.690	✓
Continental	3201-1	Fits 3200-1	White	6	13.80 lbs.	3.420	✓

Built-in Huskee® Bag Cinch secures the poly-liner to the receptacle rim, eliminating the need to tie knots in it!



[A]

3200-1 / 3201-1

[B] HUSKEE® SQUARE **EARTHTONE™**

Molded of engineered resins with seamless construction, the Huskee® is a strong, long lasting receptacle ideal for recycling applications. Available in two size options; 48 gallon with handles and 55 gallon without handles. 55 gallon receptacle accepts the 5556-1 lid.

[C] HUSKEE® DOME LID WITH HOLES **EARTHTONE™**

Molded of engineered resins with seamless construction. Accepts bottles or cans - fits the Huskee® 5555-1.

Brand	Item #	Size	Color	Case Pack	Case Weight	Case Cu. Ft.	Stock Item
Continental	4000-1	48 gal.	Blue	6	38.76 lbs.	10.920	✓
Continental	5555-1	55 gal.	Blue	6	57.60 lbs.	16.690	✓
Continental	5556-1	Fits 5555-1	Blue	1	13.80 lbs.	3.420	✓



[B]

4000-1



[C]

5556-1

WASTEBASKETS

[A] CORNER ROUND™ RECYCLING STATION EARTHTONE™

Combine the new Recycle Round™ Dolly and color-coded Corner Round™ Receptacles to create a unique recycling collection system that promotes a comprehensive recycling program. Products are sold separately, allowing the creation of customized recycling programs for any application! Corner Round™ Recycling Station is ideal for open settings like school cafeterias, atriums, foyers, food courts, airport terminals, plazas, convention centers, etc.

Brand	Item #	Size	Color	Case Pack	Case Weight	Case Cubic Ft.	Stock Item
Continental	8325-1	21 gal.	Blue	1	14.00 lbs.	4.810	✓
Continental	8325-2	21 gal.	Green	1	14.00 lbs.	4.810	✓
Continental	8325-3	21 gal.	Yellow	1	14.00 lbs.	4.810	✓
Continental	8325-4	21 gal.	Grey	1	14.00 lbs.	4.810	✓



[B] RECYCLE ROUND™ DOLLY EARTHTONE™

This black, powder-coated steel Dolly has five 3", non-marking, all swivel casters. It turns Corner Round™ Receptacles into a mobile waste collection system. Sturdy handle makes moving the unit from place to place a breeze.

Brand	Item #	Color	Case Pack	Case Weight	Case Cubic Ft.	Stock Item
Continental	8325-D	Blue	1	21.30 lbs.	5.160	✓



[C] COLOSSUS® RECYCLING STATION EARTHTONE™

These high capacity recycle stations use color-coded, hinged recycle lids to promote and encourage users to sort their recyclables! Trilingual Material ID Labels (included) make sorting recyclables easy and allows the user to customize a program to their facility. Two rigid plastic liners allow for convenient and efficient separation of recyclables for multi-stream collection. Rigid liners are easily removed for emptying and cleaning. Four color-coded lids are included.

Brand	Item #	Size	Color	Case Pack	Case Weight	Case Cubic Ft.	Stock Item
Continental	645-1	45 gal.	Blue	1	36.25 lbs.	14.319	✓
Continental	656-1	56 gal.	Blue	1	42.00 lbs.	16.529	✓



WASTEBASKETS

[A] WALL HUGGER™ RECYCLE RECEPTACLES **EARTHTONE™**

Built of durable plastic, these newly designed receptacles work efficiently in tight spaces. Their sleek, attractive design holds either 16 or 23 gallons of recyclables, but protrude less than one foot from the wall. Molded-in bag cinch eliminates the need to tie knots in poly liners. The base features molded-in hand grips which provide a secure area to grasp when lifting or dumping. Designed with smooth, seamless construction for easy cleaning and prolonged life. The 23 gallon size is 30" tall, making it ideal for placement under standard work tables.

Brand	Item #	Size	Color	Case Pack	Case Weight	Case Cu. Ft.	Stock Item
Continental	8322BK	23 gal.	Black	4	27.10 lbs.	6.200	✓
Continental	8322-1	23 gal.	Blue	4	27.10 lbs.	6.200	✓
Continental	8322-2	23 gal.	Green	4	27.10 lbs.	6.200	✓
Continental	8316BK	16 gal.	Black	4	22.50 lbs.	5.050	✓
Continental	H8322BK	23 gal. w/handles	Black	4	27.10 lbs.	7.150	✓
Continental	H8322-1	23 gal. w/handles	Blue	4	27.10 lbs.	7.150	✓
Continental	H8322-2	23 gal. w/handles	Green	4	27.10 lbs.	7.150	✓
Continental	H8316BK	16 gal. w/handles	Black	4	22.50 lbs.	5.050	✓



[B] WALL HUGGER™ MOUNTING BRACKET **EARTHTONE™**

Securely mount any Wall Hugger™ receptacle to the wall, suspending it above the floor. Elevating the receptacle allows easy cleaning of the floor under and around it. Use with 8321, 8322, H8322, 8316 and H8316 models.

Brand	Item #	Description	Color	Case Pack	Case Weight	Case Cu. Ft.	Stock Item
Continental	8319	Mounting Bracket	Grey	4	3.64 lbs.	0.040	✓



[C] WALL HUGGER™ RECYCLE LIDS **EARTHTONE™**

New style Wall Hugger™ Recycle Lids encourage users to sort their recyclables and are color-coded to make the identification easier. Fits all CCP Wall Hugger™ receptacles and competitive units.

Brand	Item #	Description	Color	Case Pack	Case Weight	Case Cu. Ft.	Stock Item
Continental	7315GY	Lid w/handles	Grey	4	4.00 lbs.	1.000	✓
Continental	7315GN	Lid w/handles	Green	4	4.00 lbs.	1.000	✓
Continental	7316GN	Lid w/holes	Green	4	4.00 lbs.	1.000	✓
Continental	7316YW	Lid w/holes	Yellow	4	4.00 lbs.	1.000	✓
Continental	7316BL	Lid w/holes	Blue	4	4.00 lbs.	1.000	✓
Continental	7317BL	Lid w/slot	Blue	4	4.00 lbs.	1.000	✓



[D] WALL HUGGER™ DOLLIES **EARTHTONE™**

The Wall Hugger™ line offers both Single and Quad-Collection Dollies. These attractive, black powder-coated steel Dollies have 3", non-marking, all swivel casters, enabling them to turn any CMC Wall Hugger™ or other receptacle into a mobile waste or recycle collection system.

Brand	Item #	Description	Color	Case Pack	Case Weight	Case Cu. Ft.	Stock Item
Continental	8320	Single Dolly	Black	2	17.00 lbs.	1.650	✓
Continental	8320-4	Quad Dolly	Black	1	18.00 lbs.	3.525	✓



WASTEBASKETS

[A] HALF ROUND WALL HUGGER™ RECYCLE RECEPTACLE **EARTHTONE™**

The Half Round completes the popular Wall Hugger™ Line. Its smaller footprint and impressive 21 gallon capacity is ideal for today's space-efficient workplace. The rounded front and sides allow use where other square or rectangular containers would interfere with traffic. The Half Rounds may be suspended off of the floor with our 8319 Mounting Bracket, found on page 110.

Brand	Item #	Size	Color	Case Pack	Case Weight	Case Cu. Ft.	Stock Item
Continental	8321-1	21 gal.	Blue	2	15.20 lbs.	8.780	✓



[B] SWINGLINE™ **EARTHTONE™**

The Continental® Square SwingLine™ containers provide 25% more capacity than round containers of the same height, which equates to labor and poly liner savings. The rolled rim provides strength as well as a convenient area to lift or pull. Reinforced base will take rough commercial use and they nest for easy storage. Two 50-1 receptacles fit on a 8320-4 Quad-Collection Dolly (seen on page 110).

[C] SWINGLINE™ TIP TOP LID **EARTHTONE™**

This lid uses gravity to create a hands-free opening. Automatically closes to conceal trash. Fits 25 and 32 gallon Swingline™ receptacles.

[D] SWINGLINE™ RECYCLE LIDS **EARTHTONE™**

These lids are specifically designed to accommodate either paper or bottle/can refuse. Both styles are available to fit any size Swingline™ Receptacle.

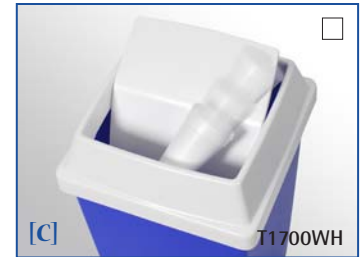

Brand	Item #	Description	Size	Color	Case Pack	Case Weight	Case Cubic Ft.	Stock Item
Continental	25-1	Swingline™ receptacle	25 gal.	Blue	4	33.80 lbs.	4.880	✓
Continental	32-1	Swingline™ receptacle	32 gal.	Blue	4	35.00 lbs.	9.820	✓
Continental	50-1	Swingline™ receptacle	50 gal.	Blue	4	64.00 lbs.	13.770	✓
Continental	T1700WH	Swingline™ Tip Top Lid	fits 25-1 & 32-1	White	4	11.80 lbs.	2.240	✓
Continental	1725-1	Swingline™ Recycle Lid w/slot	fits 25-1 & 32-1	Blue	4	7.50 lbs.	2.915	✓
Continental	1750-1	Swingline™ Recycle Lid w/slot	fits 50-1	Blue	2	7.70 lbs.	2.679	✓
Continental	1725-2	Swingline™ Recycle Lid w/hole	fits 25-1 & 32-1	Blue	4	7.50 lbs.	2.915	✓
Continental	1750-2	Swingline™ Recycle Lid w/hole	fits 50-1	Blue	2	7.70 lbs.	2.679	✓

[E] COMMERCIAL WASTEBASKET **EARTHTONE™**

The low profile design of these rectangular wastebaskets make them ideal for a variety of recycle applications ranging from classroom, office, commercial or institutional use.

Brand	Item #	Size	Color	Case Pack	Case Weight	Case Cu. Ft.	Stock Item
Continental	1358-1	13 ⁵ / ₈ qt. Rectangle	Blue	12	15.00 lbs.	1.680	✓
Continental	1358-2	13 ⁵ / ₈ qt. Rectangle	Green	12	15.00 lbs.	1.680	✓
Continental	2818-1	28 ¹ / ₈ qt. Rectangle	Blue	12	27.00 lbs.	2.880	✓
Continental	2818-2	28 ¹ / ₈ qt. Rectangle	Green	12	27.00 lbs.	2.880	✓
Continental	4114-1	41 ¹ / ₈ qt. Rectangle	Blue	12	35.16 lbs.	3.480	✓
Continental	4114-2	41 ¹ / ₈ qt. Rectangle	Green	12	35.16 lbs.	3.480	✓



WASTEBASKETS

[A] CURBSIDE BIN **EARTHTONE™**

Used by environmentally conscious cities for curbside recycle collection. This bin is durable and lightweight. Drain holes in base of bin prevent accumulation of rainwater. Notched sides allow units to be cross-stacked. For convenient indoor recycle collection, one or two Curbside Bins can be used with the MFT-5BK Trolley (details on page 23).

Brand	Item #	Size	Color	Case Pack	Case Weight	Case Cu. Ft.	Stock Item
Continental	5914-1	14 gal.	Blue	12	47.40 lbs.	6.600	✓



[B] TILT-N-WHEEL® **EARTHTONE™**

These 50 gallon containers have a hinged double walled lid with standard 8" non-marking wheels.

Brand	Item #	Size	Color	Case Pack	Case Weight	Case Cu. Ft.	Stock Item
Continental	5850-1	50 gal.	Blue	2	56.00 lbs.	18.540	✓



[C] CUBE TRUCK **EARTHTONE™**

This 16 cubic foot Cube Truck features 3" casters placed in a diamond configuration. Two stationary and two fixed casters allow this unit to be turned on its own axis for greater mobility. Ideal for bulk recycle collection.

Brand	Item #	Size	Color	Case Pack	Case Weight	Case Cu. Ft.	Stock Item
Continental	5916-1	16 cu. ft.	Blue	1	50.00 lbs.	25.460	✓



[D] TILT TRUCK **EARTHTONE™**

Features one-piece, extra strong seamless industrial plastic construction. Inset wheel placement prevents wall/door damage and allows for nesting in shipment and in storage. Fits through standard office doorways. 750 lb. capacity.

Brand	Item #	Size	Color	Case Pack	Case Weight	Case Cu. Ft.	Stock Item
Continental	5840-1	5/8 cu. yd.	Blue	1	79.00 lbs.	43.110	✓



CARTS & ACCESSORIES

Choose from our diverse line of utility and service/bussing carts to fit your specific need. Our carts and accessories are durable, easy to clean and highly maneuverable ... and are designed to optimize storage and increase productivity. Pneumatic casters, available on some models, provide quiet operation on rough surfaces.

[A] ECONOMY LODGING CART

The Economy Lodging Cart has ergonomic aluminum handles to grab and turn from any position. Vacuum cleaner ledge and handle notch are standard. Built-in tool holders for common cleaning items as well as 'well-type' pockets to hold standard quart cleaning bottles. Shelf is adjustable (without tools) and can be moved to one of two standard locations. Center wheel design allows for a 360° turning radius. Vinyl bag included.

[B] DELUXE LODGING CART

This cart offers all the features of the above Economy model, plus sliding doors with a lock, which creates a secure area. Ideal for health care or other areas where security is necessary.

[C] LODGING CART DOOR SET

Doors come standard on the Deluxe model, and can be ordered for the Economy model. Door Set comes complete with lock and key.

[D] LODGING CART REPLACEMENT VINYL BAG

This six bushel Vinyl Replacement Bag is great for wet linens. Zippered for easy waste or linen removal.

[E] LODGING CART ADJUSTABLE SHELF

One adjustable shelf comes standard on both models. Both will accommodate two shelves.



Brand	Item #	Description	Size	Color	Case Pack	Case Weight	Case Cu. Ft.	Stock Item
Continental	1580BEBN	Economy Lodging Cart	62" x 25 1/2" x 49 1/2"	Beige/Brown	1	118.00 lbs.	29.760	✓
Continental	1585BEBN	Deluxe Lodging Cart	62" x 25 1/2" x 49 1/2"	Beige/Brown	1	142.00 lbs.	29.760	✓
Continental	1565BE	Lodging Cart Door Set	- - -	Beige	1	12.50 lbs.	2.130	✓
Continental	1594BN	Replacement Vinyl Bag	- - -	Brown	6	7.32 lbs.	0.630	✓
Continental	1590BE	Lodging Cart Adjustable Shelf	- - -	Beige	1	5.50 lbs.	0.910	✓

CARTS & ACCESSORIES

[A] MAID CARRIERS

Seamless, high-impact plastic is durable and chemical resistant. Fits most hotel and janitorial carts. Maxi accommodates up to 4 1/4" diameter bottles.

Brand	Item #	Size	Color	Case Pack	Case Weight	Case Cu. Ft.	Stock Item
Continental	48	Standard	Grey	6	8.46 lbs.	1.690	✓
Continental	49	Maxi	Grey	6	17.46 lbs.	3.160	✓



[B] HUSKEE® FOLDING CART

Structural plastic frame folds for storage and includes a six bushel vinyl bag (276). Vinyl Replacement Bags are available. Also accommodates two 8322 receptacles for waste or recycle collection.

[C] HUSKEE® FOLDING CART VINYL REPLACEMENT BAG

[D] HUSKEE® FOLDING CART 10 POCKET CADDY BAG



Brand	Item #	Description	Size	Color	Case Pack	Case Weight	Case Cubic Ft.	Stock Item
Continental	275	Huskee® Folding Cart	37 1/2" x 28" x 36 1/4"	Blue	1	24.70 lbs.	4.530	✓
Continental	276	Vinyl Replacement Bag	29 1/2" x 20 1/2" x 20"	Yellow	6	6.18 lbs.	0.240	✓
Continental	277	10 Pocket Caddy Bag	24" x 19"	Yellow	6	4.08 lbs.	0.180	✓



[E] FOLDING CART FRAMES & DUCK BAGS

These Folding Carts have steel frames. Choose between the 54 Folding Cart Frame with shelf or the 55 Folding Cart Frame with snap lock braces. The 51 Duck Bag and the 59 Pocket Caddy Bag are compatible with these frames. Carts and bags are sold separately.



Brand	Item #	Description	Size	Color	Case Pack	Case Weight	Case Cubic Ft.	Stock Item
Continental	54	Folding Cart w/shelf		Grey	1	19.63 lbs.	3.960	✓
Continental	55	Folding Cart w/snap Lock Braces		Grey	1	14.30 lbs.	3.960	✓
Continental	51	Vinyl Replacement Bag	6 Bushels	Dark Blue	6	7.92 lbs.	0.360	✓
Continental	59	10 Pocket Caddy Bag		Dark Blue	6	6.72 lbs.	0.720	✓

CARTS & ACCESSORIES

[A] DELUXE STEEL HAND TRUCK

Handles cartons or drums up to 55 gallons. Blue enamel finish is rust and corrosion resistant. Large, 10" x 2 3/4", solid wheels for durability.

Brand	Item #	Color	Case Pack	Case Weight	Case Cubic Ft.	Stock Item
Continental	43	Dark Blue	1	36.13 lbs.	7.370	✓



[B] PNEUMATIC UTILITY CART

The heavy-duty plastic construction is lightweight and durable, designed to handle applications from health care to industrial. The 8" fully pneumatic casters and all plastic design provide a cushioned, quiet ride that is ideal for transporting fragile items over rough surfaces. Derma-Tek® smooth skin, non-porous finish is easy to clean and provides a professional appearance that will not peel, chip, crack or fade like conventional metal units. Supports 200 lbs. per shelf, 400 lbs. maximum capacity. Compatible with 5806 Optional Center Shelf.

Brand	Item #	Size	Color	Case Pack	Case Weight	Case Cu. Ft.	Stock Item
Continental	5805BE-PN	40 3/8" x 25 1/2" x 37"	Beige	1	72.15 lbs.	5.860	✓
Continental	5805GY-PN	40 3/8" x 25 1/2" x 37"	Grey	1	72.15 lbs.	5.860	✓



[C] UTILITY CART

The 5800 and 5805 two shelf Utility Carts feature 5" heavy-duty, non-marking grey casters for industrial use. Supports 200 lbs. per shelf, 400 lbs. maximum capacity. Optional center shelf available.

[D] OPTIONAL CENTER SHELF

Brand	Item #	Size	Color	Case Pack	Case Weight	Case Cu. Ft.	Stock Item
Continental	5800BE	34 3/8" x 17 1/2" x 33"	Beige	1	32.90 lbs.	3.440	✓
Continental	5800GY	34 3/8" x 17 1/2" x 33"	Grey	1	32.90 lbs.	3.440	✓
Continental	5805BE	40 3/8" x 25 1/2" x 33"	Beige	1	42.60 lbs.	5.860	✓
Continental	5805GY	40 3/8" x 25 1/2" x 33"	Grey	1	42.60 lbs.	5.860	✓
Continental	5801BE	Shelf / fits all 5800 Carts	Beige	1	10.40 lbs.	1.470	✓
Continental	5801GY	Shelf / fits all 5800 Carts	Grey	1	10.40 lbs.	1.470	✓
Continental	5806BE	Shelf / fits all 5805 Carts	Beige	1	16.50 lbs.	2.590	✓
Continental	5806GY	Shelf / fits all 5805 Carts	Grey	1	16.50 lbs.	2.590	✓



[E] SERVICE/BUSSING CART

Three shelf cart features 4" heavy-duty, non-marking grey casters. Applications range from industrial use to food service and bussing. Supports 200 lbs. per shelf, 400 lbs. maximum capacity. Accepts, without tools, the 5811 and 5812 silverware and refuse bins (found on page 116).

Brand	Item #	Size	Color	Case Pack	Case Weight	Case Cu. Ft.	Stock Item
Continental	5810BE	31 1/4" x 16 1/2" x 36 3/8"	Beige	1	24.33 lbs.	4.340	✓
Continental	5810BK	31 1/4" x 16 1/2" x 36 3/8"	Black	1	24.33 lbs.	4.340	✓



DERMA-TEK®
is a smooth, nonporous finish that is tough, durable and seamless – making it easy to clean and keep clean, while providing a professional appearance. Plus, Derma-Tek® will not absorb chemicals, liquids or odors and will not rust, dent, chip or corrode.

CARTS & ACCESSORIES

[A] SILVERWARE & REFUSE BINS

These durable polyethylene silverware and refuse bins complete the popular Continental® bussing cart. Both bins fit all the popular style bussing carts resulting in a collection system that can be used for a multitude of applications. The Silverware Bin easily holds 100 complete place settings of flatware to service the clean up of a small meeting or party. Compatible with the 5810 Service/Bussing Cart.

Brand	Item #	Size	Color	Case Pack	Case Weight	Case Cu. Ft.	Stock Item
Continental	5811BK	20.00 gal.	Black	2	4.00 lbs.	1.080	✓
Continental	5812BK	9.00 gal.	Black	2	8.00 lbs.	2.400	✓



BUSS TUBS

These tubs are durable, easy to clean and are NSF Listed, Std 2 Direct Food Contact (white and grey). These items are ideal for food preparation and storage, as well as for traditional food service and bussing applications. Tubs are commercial freezer and dishwasher safe (-40° to 150°F).

[B] BUS TUBS & COVERS

Heavy-duty, reinforced rolled rim increases strength while reducing distortion and breakage, protecting costly dishes and glassware. Comfortable hand-holds in both the short and long sides of the tubs ensure a solid and comfortable grip! Recessed lid design allows the bus tubs to be stacked securely for transport or storage.



Brand	Item #	Description	Size	Color	Case Pack	Case Weight	Case Cubic Ft.	Stock Item
Continental	1525WH	4 ⁵ / ₈ gallon Bus Tub	20" x 15" x 5"D	White	12	20.00 lbs.	3.960	✓
Continental	1525WH-BP	4 ⁵ / ₈ gallon Bus Tub - Bulk	20" x 15" x 5"D	White	210	368.00 lbs.	55.430	✓
Continental	1525GY	4 ⁵ / ₈ gallon Bus Tub	20" x 15" x 5"D	Grey	12	20.00 lbs.	3.960	✓
Continental	1525GY-BP	4 ⁵ / ₈ gallon Bus Tub	20" x 15" x 5"D	Grey	210	368.00 lbs.	55.430	✓
Continental	1525BK-BP	4 ⁵ / ₈ gallon Bus Tub	20" x 15" x 5"D	Black	210	368.00 lbs.	55.430	✓
Continental	1530WH	Bus Tub Lid	20" x 15" x 1"D	White	12	12.60 lbs.	1.940	✓
Continental	1530GY	Bus Tub Lid	20 ¹ / ₂ " x 15 ⁵ / ₈ " x 1"D	Grey	12	12.60 lbs.	1.940	✓



STORAGE SHELVES

Keep your space clean and organized with our sturdy, easy-to-clean shelves. From our NSF approved ventilated shelf to our super heavy-duty Structo Tuff™ Shelf, we have the right product for your application. No tools needed for assembly.

[A] STRUCTO TUFF™ SHELF

Structo Tuff™ Shelves are ideal for commercial use with chemical dispensing jugs, office supplies and other items in warehouses, offices and janitor closets. Fast, easy assembly without tools. Holds up to 250 lbs. per shelf.

[B] VENTILATED STORAGE SHELF

Ventilated Storage Shelf design allows for a moisture and dust free storage environment for all your supplies. "Quick Assembly" socket and column system - no tools needed. Holds up to 150 lbs. per shelf.

[C] NSF® VENTILATED STORAGE SHELF

Ventilated Storage Shelf design allows for a moisture and dust free storage environment for all your supplies with base leveling feet. NSF® listed. Holds up to 150 lbs. per shelf. Includes practical 6" leveling feet for cleaning and stability.

Brand	Item #	Size	Color	Case Pack	Case Weight	Case Cu. Ft.	Stock Item
Continental	4418-5GY	40" x 18" x 72"	Dark Grey	1	71.00 lbs.	7.580	✓
Continental	64840Y	36 1/4" x 18 1/8" x 54 1/4"	Oyster	1	24.66 lbs.	4.220	✓
Continental	64850Y	36 1/4" x 18 1/8" x 60 1/4"	Oyster	1	27.06 lbs.	4.220	✓



[D] PLASTIC STEP STOOL

This structural plastic step stool is rugged enough to hold up to 350 lbs. The molded-in no-slip surface prevents falls. Four retractable, non-marking casters and an anti-skid bottom makes it easy to maneuver and hold it in place during use.

Brand	Item #	Color	Case Pack	Case Weight	Case Cubic Ft.	Stock Item
Continental	523BK	Black	1	8.30 lbs.	1.310	✓
Continental	523TN	Tan	1	8.30 lbs.	1.310	✓



DUNNAGE RACKS

Food storage solutions that meet NSF, FDA and USDA requirements.

[A] DUNNAGE RACK

These racks are the best solution for your storage needs. Made of durable polyethylene construction, these units won't rust, dent, chip or corrode like metal units. The light textured surface is easy to wipe-off or steam clean. The Dunnage-Key connector storage slot allows for storage when not in use and is sloped to allow for drainage when cleaning. Ventilation slots allow air to circulate under stored goods, promoting longer shelf life. Racks can be joined together in end-to-end, back-to-back or in a L or U shape, to accommodate all storage needs. 12" height meets NSF®, FDA and USDA requirements and meets food codes and H.A.C.C.P.'s food storage requirements. Two keys are furnished with each rack. Additional keys available.



[B] DUNNAGE RACK KEY

Brand	Item #	Size	Load Capacity	Color	Case Pack	Case Weight	Case Cubic Ft.	Stock Item
Continental	5930	30" x 22" x 12"	1,500 lbs.	Grey	1	16.00 lbs.	4.950	✓
Continental	5936	36" x 22" x 12"	1,500 lbs.	Grey	1	19.50 lbs.	5.920	✓
Continental	5948	48" x 22" x 12"	3,000 lbs.	Grey	1	29.50 lbs.	7.810	✓
Continental	5960	60" x 22" x 12"	3,000 lbs.	Grey	1	32.50 lbs.	9.740	✓
Continental	5906	---	---	Yellow	6	0.28 lbs.	0.010	✓

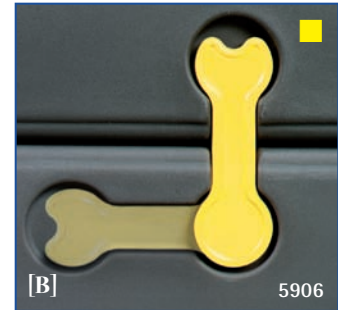

INGREDIENT BINS

Convenient, portable storage bins for large quantities of any type of food ingredient, such as flour, sugar, rice, vegetables, etc. Choose from our unique Mobile Ingredient Bins or Economy Bins. All are equipped with non-marking casters.

[C] ECONOMY INGREDIENT BIN

The 9332, 32 gallon Economy Ingredient Bin will hold 243 lbs. (110 Kg) of sugar and 192 lbs. (87 Kg) of flour. Square mobile bin has snap-on lid and dolly for added mobility.

Brand	Item #	Size	Load Capacity	Color	Case Pack	Case Weight	Case Cubic Ft.	Stock Item
Continental	9332	21 $\frac{1}{2}$ " x 25" x 27 $\frac{1}{2}$ "	32 gal., 4.28 cu. ft.	White	1	37.60 lbs.	7.980	✓



INGREDIENT BINS

[A] MOBILE INGREDIENT BINS

The two-piece clear polycarbonate lid and unique sloped front let you see exactly what's inside and then open easily. You have access to your ingredients without having to move the bin from under the counter. Two-piece lids are removable for easy filling, tilt up or slide back for convenient access. Units are equipped with four 3" non-marking casters, two swivel for fingertip maneuverability and two are fixed. The Ingredient Bin body is constructed of durable Derma-Tek® smooth surface plastic. The seamless walls and round corner design make cleaning simple and thorough. Poly-clear lid lets you see exactly what is inside.

The 9321, 21 gallon Ingredient Bin holds 160 lbs. (71kg) of sugar and 126 lbs. (56 kg) of flour, while the 9326, 26 gallon Ingredient Bin holds 179 lbs. (80kg) of sugar and 140 lbs. (62 kg) of flour.

Brand	Item #	Size	Load Capacity	Color	Case Pack	Case Weight	Case Cubic Ft.	Stock Item
Continental	9321	27 ³ / ₄ " x 12 ³ / ₄ " x 29 ¹⁵ / ₁₆ "	21 gal., 2.81 cu. ft.	White	1	25.53 lbs.	5.430	✓
Continental	9326	27 ³ / ₄ " x 15 ¹ / ₄ " x 29 ¹⁵ / ₁₆ "	26 gal., 3.48 cu. ft.	White	1	28.90 lbs.	5.430	✓



[B] CRISPER BIN

The Crisper comes complete with the dolly, base container, perforated liner, lid and drain spigot. Easily transports produce from prep area to walk-in. Twist-on, twist-off dolly allows for easy mobility, even when full. The convenient drain faucet eliminates lifting and tipping when draining the contents. Continental® Crispers are made of USDA accepted materials and comply with FDA regulations.

Brand	Item #	Size	Load Capacity	Color	Case Pack	Case Weight	Case Cubic Ft.	Stock Item
Continental	2807WH	21 ¹ / ₂ " x 25" x 34 ¹ / ₄ "	32 gallons	White	1	27.14 lbs.	9.260	✓



ICE BINS

Safely transport ice to serving bars, ice dispensers, portable bars, etc. NSF Listed for direct food contact (Standard 2).

[C] CONSERV ICE BIN

Metal free bin and lid are designed to eliminate unsightly rust and corrosion. The patented multi-position, self-storing lid allows for greater access to bin contents while preventing lid contamination. Built-in, front assist handle allows for easy vehicle loading and unloading. The easy to access and leak-proof drain faucet is nested within the profile of the body to prevent accidental damage. These units provide efficient storage and functionality with a reduced and common footprint design. Both the 125 and 200 lb. Ice Bins share interchangeable lids and faucet. The ergonomic handles and large dolly-style rear wheels allow units to be easily rolled and maneuvered over grass, tile or up curbs or steps.



Brand	Item #	Size	Load Capacity	Color	Case Pack	Case Weight	Case Cubic Ft.	Stock Item
Continental	9720BE	28 ¹ / ₄ " x 22 ¹ / ₂ " x 44"	200 lbs.	Beige	1	57.50 lbs.	16.420	✓
Continental	9720BK	28 ¹ / ₄ " x 22 ¹ / ₂ " x 44"	200 lbs.	Black	1	57.50 lbs.	16.420	✓
Continental	9725BE	28 ¹ / ₄ " x 22 ¹ / ₂ " x 33 ¹ / ₂ "	125 lbs.	Beige	1	45.50 lbs.	12.680	✓
Continental	9725BK	28 ¹ / ₄ " x 22 ¹ / ₂ " x 33 ¹ / ₂ "	125 lbs.	Black	1	45.50 lbs.	12.680	✓



ICE BINS

[A] HUSKEE® "ICE ONLY" ROUND

The 10 gallon "ICE ONLY" Huskee® Round Receptacle is NSF Listed - Standard 2 for direct food contact to ensure safe food handling and to comply with HACCP guidelines. Available in white with permanent black "ICE ONLY" imprint. Holds approximately 40 lbs. of ice. Compatible with 1002 Huskee Lid (see chart on page 94).

Brand	Item #	Size	Color	Case Pack	Case Weight	Case Cu. Ft.	Stock Item
Continental	1001-ICE	10 gal.	White	6	19.14 lbs.	5.400	✓



SCOOPS, MEASURES & PITCHERS

Our clear Scoops, Measures and Pitchers are constructed of durable polycarbonate. These classic products are NSF approved and dishwasher safe.

[B] SCOOPS

These scoops resist chipping, scratches and breakage and are lighter weight than metal. With a beveled front edge for maximum pickup, a hanging slot for efficient storage and a thumb indent for greater control, these scoops will prove to be efficient and long lasting.



Brand	Item #	Description	Size	Color	Case Pack	Case Weight	Case Cubic Ft.	Stock Item
Continental	9906	Bar Scoop	6 oz.	Clear	12	2.64 lbs.	0.360	✓
Continental	9932	Utility Scoop	32 oz.	Clear	12	5.88 lbs.	1.080	✓
Continental	9964	Large Utility Scoop	64 oz.	Clear	6	4.08 lbs.	1.840	✓

[C] MEASURES

Graduations embossed in metric and English on opposite sides, will not wash off. These measures have a self-draining bottom and an "I-Beam" handle with thumb grip control. Dishwasher and freezer safe from -40° F to 212° F (-40° C to 100° C).

Brand	Item #	Size	Color	Case Pack	Case Weight	Case Cu. Ft.	Stock Item
Continental	9808	1 cup	Clear	12	1.44 lbs.	0.180	✓
Continental	9816	1 pint	Clear	6	1.62 lbs.	0.420	✓
Continental	9832	1 qt.	Clear	6	2.58 lbs.	0.780	✓
Continental	9864	2 qt.	Clear	6	3.96 lbs.	1.380	✓
Continental	9828	4 qt.	Clear	6	6.54 lbs.	2.400	✓

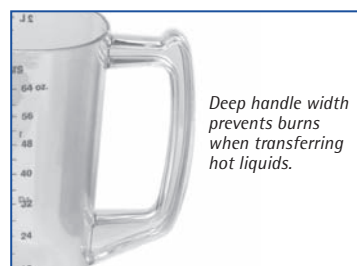

SCOOPS, MEASURES & PITCHERS

BEAUTY, CONVENIENCE AND STRENGTH

Once you try our 60 ounce Tri-Pour Pitcher, you'll never use another pitcher again! The Continental® Tri-Pour puts an end to awkward, messy serving problems. Don't let the surprisingly light weight fool you, this pitcher is 20% heavier than any competitive product in the market today. What does that mean? Increased wall thickness equals increased strength and prolonged life.

The Tri-Pour Pitcher resists chipping, scratches and breakage. Designers have provided an attractive cut crystal appearance, a look similar to Waterford at a fraction of the cost, to provide an elegance appropriate for any décor.

[A] TRI-POUR PITCHER

The unique drip-proof spout with three-lip design allows servers to use the front when pouring liquids only, or out of either side when ice is also desired. Tri-Pour Pitchers are manufactured of durable poly-clear. Temperatures rated safe from -40°F to 212° F (-40°C to 100°C).

Brand	Item #	Size	Color	Case Pack	Case Weight	Case Cu. Ft.	Stock Item
Continental	9762CL	60 oz..	Clear	6	5.34 lbs.	1.260	✓



PLATFORM TRUCKS

Continental® offers three grades of platform trucks in two popular sizes. Removable handles enable them to be used in a variety of hauling situations.

[B] PLATFORM TRUCKS

Structural plastic construction and rounded corners protect against accidental wall and door damage. No bumpers required. Plastic construction will not rust, dent, crack, chip, peel or splinter unlike conventional metal or wood. All platform trucks come in charcoal grey and feature a heavy-duty, reinforced steel handle.



Brand	Item #	Description	Capacity	Caster Size	Deck Size	Color	Case Pack	Case Weight	Case Cu. Ft.	Stock Item
Continental	5860	Utility	700 lbs.	5"	24" x 48"	Grey	1	68.06 lbs.	6.420	✓
Continental	5865	Standard	1,200 lbs.	6"	24" x 48"	Grey	1	75.50 lbs.	7.170	✓
Continental	5870	Heavy-Duty	2,200 lbs.	8"	24" x 48"	Grey	1	78.88 lbs.	8.500	✓
Continental	5875	Utility	700 lbs.	5"	30" x 60"	Grey	1	72.56 lbs.	10.030	✓
Continental	5880	Standard	1,200 lbs.	6"	30" x 60"	Grey	1	80.00 lbs.	11.200	✓
Continental	5885	Heavy-Duty	2,200 lbs.	8"	30" x 60"	Grey	1	83.38 lbs.	13.280	✓



TILT & CUBE TRUCKS

Tilt Trucks are available in various sizes and capacities - all come standard with heavy gauge, enamel-coated steel frames. Featuring zinc-plated caster housings and hardware, these units are designed to last. The metal frames are tucked into the profile of the units to support heavy loads and to prevent bulging and tub distortion.

Cube Trucks are so agile that they can literally turn on a dime! Their 400 pound capacity is ideal for a variety of industrial and commercial uses.

[A] 5/8 CUBIC YARD TILT TRUCKS

All models feature one-piece extra strong seamless industrial plastic construction. Inset wheel placement prevents wall/door damage and allows for nesting in shipment and in storage. Fits through standard office doorways. Optional domed, center-hinged lid helps to contain odors and keep pests out. Stainless steel piano hinge will not rust.



Available in a Recycle model, see page 112 for details.

[B] 1.1 CUBIC YARD TILT TRUCKS

All models are equipped with deluxe roller bearing wheels and heavy-duty casters. Wheels are inset to fit standard office doorways and to reduce wall and door damage. This Tilt Truck is easily handled by one person and can be easily cleaned with steam or high pressure hot water. Optional domed, center-hinged lid helps to contain odors and keep pests out. Stainless steel piano hinge will not rust.

[C] 1.5 CUBIC YARD TILT TRUCKS

All models are equipped with deluxe roller bearing wheels and heavy-duty casters. This Tilt truck is easily handled by one person and is ideal for industrial/commercial applications. Optional domed, center-hinged lid helps to contain odors and keep pests out. Stainless steel piano hinge will not rust.



Brand	Item #	Description	Capacity	Color	Case Pack	Case Weight	Case Cu. Ft.	Stock Item
Continental	5839BK	5/8 Cu. Yd. Utility Tilt Truck	300 lbs.	Black	1	59.00 lbs.	43.110	✓
Continental	5840BK	5/8 Cu. Yd. Standard Tilt Truck	750 lbs.	Black	1	79.00 lbs.	43.110	✓
Continental	5845BK	5/8 Cu. Yd. Heavy-Duty Tilt Truck	1,200 lbs.	Black	1	81.00 lbs.	43.110	✓
Continental	5843BK	Cover - fits all 5/8 cu. yd. tilt trucks	---	Black	1	22.52 lbs.	8.640	✓
Continental	5833BK	1.1 Cu. Yd. Standard Tilt Truck	800 lbs.	Black	1	98.00 lbs.	55.280	✓
Continental	5835BK	1.1 Cu. Yd. Heavy-Duty Tilt Truck	2,000 lbs.	Black	1	151.00 lbs.	55.280	✓
Continental	5837BK	Cover - fits all 1.1 cu. yd. tilt trucks	---	Black	1	22.52 lbs.	8.640	✓
Continental	5849BK	1.5 Cu. Yd. Standard Tilt Truck	1,20 lbs.	Black	1	202.00 lbs.	102.380	✓
Continental	5852BK	1.5 Cu. Yd. Heavy-Duty Tilt Truck	2,100 lbs.	Black	1	151.00 lbs.	102.380	✓
Continental	5853BK	Cover - fits all 1.5 cu. yd. tilt trucks	---	Black	1	32.00 lbs.	18.300	✓

TILT & CUBE TRUCKS

[A] 5/8 CUBIC YARD TILT TRUCKS

This 16 cubic foot Cube Truck features 3" casters placed in a diamond configuration. Two stationary and two fixed casters allow this unit to be turned on its own axis for greater mobility. Ideal for bulk linen collection and general material handling.



Available in a Recycle model, see page 112 for details.

Brand	Item #	Size	Color	Case Pack	Case Weight	Case Cu. Ft.	Stock Item
Continental	5916BK	16 cu. ft.	Black	1	50.00 lbs.	43.110	✓



ODOR CONTROL

Our odor control products help you achieve customer satisfaction by providing a cleaner, more pleasant atmosphere.

[B] STANDARD KLEEN TECH™ AEROSOL DISPENSER

This dispenser has a refill reminder and is made out of chemical resistant plastic. 15 minute spray cycle. Effectively controls odors up to 6,000 cubic feet. Accommodates most metered aerosols. "D" cell batteries not included.

[C] DELUXE KLEEN TECH™ MULTI-FUNCTION AEROSOL DISPENSER

This dispenser has a real time clock, adjustable spray interval and can be programmed with a start and stop time and a five or seven day schedule. Effectively controls odors up to 6,000 cubic feet. Accommodates most metered aerosols. "D" cell batteries not included.

Brand	Item #	Description	Color	Case Pack	Case Weight	Case Cu. Ft.	Stock Item
Continental	1191	Standard Dispenser	Beige	6	9.00 lbs.	0.600	✓
Continental	1190	Deluxe Dispenser	White	6	9.00 lbs.	0.600	✓



[D] KLEEN TECH™ METERED AEROSOLS

These aerosols are a dry-type formula. Their dual odor counteractants are ideal for office areas, schools, institutions, healthcare, restaurants, hotels, gyms, rest rooms, etc. Seven ounce with universal actuator tip. 3,400 metered sprays per can.

Brand	Item #	Description	Color	Case Pack	Case Weight	Case Cu. Ft.	Stock Item
Continental	1181	Floral	Pink	12	8.64 lbs.	0.360	✓
Continental	1182	Nautical Mist	Blue	12	8.64 lbs.	0.360	✓
Continental	1183	Garden Apple	Green	12	8.64 lbs.	0.360	✓
Continental	1184	Baby Powder	Blue	12	8.64 lbs.	0.360	✓
Continental	1185	Vanilla - Odor Neutralizer	Beige	12	8.64 lbs.	0.360	✓
Continental	1186	Lemon	Yellow	12	8.64 lbs.	0.360	✓
Continental	1187	Cinnamon	Orange	12	8.64 lbs.	0.360	✓



ODOR CONTROL

[A] KLEEN AIRE™ CABINET

Continuous operation fan model. "D" cell batteries not included. Accommodates gels up to 2 7/8" diameter.

[B] MULTI-FUNCTION KLEEN AIRE™ CABINET

Multi-function fan unit with on/off switch, L.E.D. and light sensor. "D" cell batteries not included. Accommodates gels up to 2 7/8" diameter.

Brand	Item #	Description	Color	Case Pack	Case Weight	Case Cu. Ft.	Stock Item
Continental	NI100	Cabinet	White	12	11.40 lbs.	0.720	✓
Continental	NI101MF	Multi-Function Cabinet	White	12	11.40 lbs.	0.720	✓

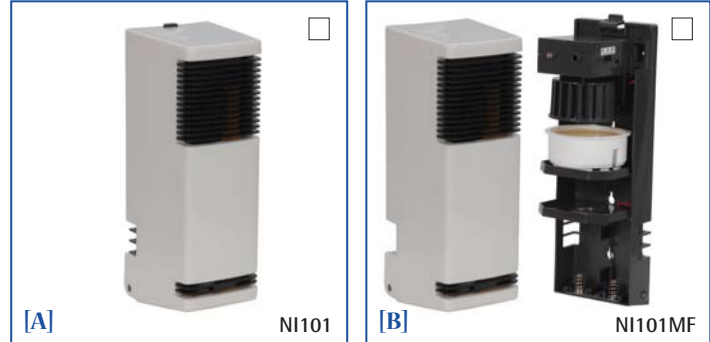

[C] KLEEN AIRE™ NEUTRALIZER GELS

Four different organic fragrances attack and neutralize odors anywhere they occur. Accommodates most gel cabinets.

Brand	Item #	Description	Color	Case Pack	Case Weight	Case Cu. Ft.	Stock Item
Continental	104	Cinnamon	Orange	1 dz.	2.00 lbs.	0.160	✓
Continental	105	Garden Apple	Green	1 dz.	2.00 lbs.	0.160	✓
Continental	106	Lemon/Lime	Green	1 dz.	2.00 lbs.	0.160	✓
Continental	107	Wild Flower	Blue	1 dz.	2.00 lbs.	0.160	✓



[D] KLEEN BOWL AUTOMATIC TOILET BOWL CLEANER

An in-tank cleaner with a bluing agent that saves time and money while preventing scale build-up. Bluing agent released with each flush so you know that it's working. Net weight is nine ounces per unit. Offers approximately 30 days protection.

Brand	Item #	Case Pack	Case Weight	Case Cubic Ft.	Stock Item
Continental	P222	12	11.00 lbs.	0.420	✓



[E] KLEEN AIRE™ WICK AIR FRESHENER

A long lasting economical way to control odors. Designed to freshen 1,500 cubic feet for 45-60 days. Non-spill 1.5 ounce bottle with adjustable wick is VOC compliant. Mini cabinet houses freshener and provides a professional appearance. Available in Cherry and Lemon fragrances. (One cabinet provided with each dozen fresheners.)

Brand	Item #	Scent	Case Pack	Case Weight	Case Cubic Ft.	Stock Item
Continental	153	Cherry	6 dz.	12.96 lbs.	0.810	✓
Continental	154	Lemon	6 dz.	12.96 lbs.	0.810	✓



[F] KLEEN AIRE™ INSTANT ABSORBENT

Transforms liquids into a manageable gel. Contains both a biocide and quat to eliminate odors on contact. Absorbs 60 times its weight in liquid instantly; soaks up vomit, blood, urine and other spills, saving clean-up time. Ideal for restaurants, grocery, health care, day care, schools and institutions.

[G] KLEEN AIRE™ CARPET & ROOM DEODORIZER & ABSORBENT

Eliminates carpet and room odors while freshening the entire area. Use with regular vacuuming or directly on a spill. Light weight and non-abrasive; will not harm carpets or vacuums. Contains sodium bicarbonate to eliminate smoke, must and pet odors. Absorbs and deodorizes oil, vomit, urine, blood and many other spills.



Brand	Item #	Description	Scent	Case Pack	Case Weight	Case Cu. Ft.	Stock Item
Continental	P129-1	Kleen Aire™ Instant Absorbent / 12 ounce shaker bottles	Lemon	48	49.54 lbs.	2.740	✓
Continental	P135-1	Kleen Aire™ Carpet & Room Deodorizer & Absorbent / 12 ounce shaker bottles	Lemon	48	36.00 lbs.	2.740	✓

URINAL MATS & SCREENS

Guard against unpleasant odors and protect your floors with our complete line of floor mats and screens. These functional products offer a variety of benefits, including cost savings for daily maintenance.

[A] KLEEN SCREEN URINAL SCREENS

Four ounce enzymatic deodorant block contains surfactants and chelating agents to clean and deodorize for 30 days (up to 2,000 flushes)- coloring agents are released with each flush so you know that it's working. Increased ventilation reduces potential splash back and flexible screen traps more debris to prevent costly drain clogs.

[B] DEOD-O-SCREEN

Vinyl urinal screen has 30-45 days of built-in deodorant. Universal shape fits most urinals. Available in four popular fragrances: Floral, Pine, Citrus and Strawberry. Disposable poly-glove included. Each screen is individually packaged.

[C] CONTOURED URINAL SCREEN

100% vinyl screens contoured fit for most urinals. Non-scented.

Brand	Item #	Description	Color	Case Pack	Case Weight	Case Cu. Ft.	Stock Item
Continental	165-1	Cleen Screen / Floral	Blue	1 dz.	3.74 lbs.	0.370	✓
Continental	165-2	Cleen Screen / Pine	Green	1 dz.	3.74 lbs.	0.370	✓
Continental	165-3	Cleen Screen / Citrus	Orange	1 dz.	3.74 lbs.	0.370	✓
Continental	165-4	Cleen Screen / Strawberry	Red	1 dz.	3.74 lbs.	0.370	✓
Continental	164-1	Deod-O-Screen / Floral	Blue	6 dz.	3.74 lbs.	0.370	✓
Continental	164-2	Deod-O-Screen / Pine	Green	6 dz.	3.74 lbs.	0.370	✓
Continental	164-3	Deod-O-Screen / Citrus	Orange	6 dz.	3.74 lbs.	0.370	✓
Continental	164-4	Deod-O-Screen / Strawberry	Red	6 dz.	3.74 lbs.	0.370	✓
Continental	160A	Contoured Urinal Screen	Blue	10	4.40 lbs.	0.200	✓

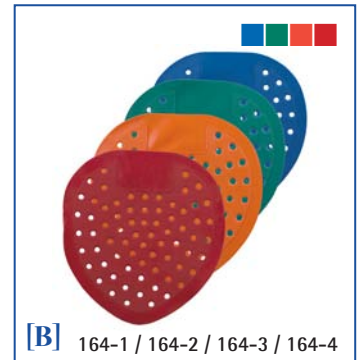
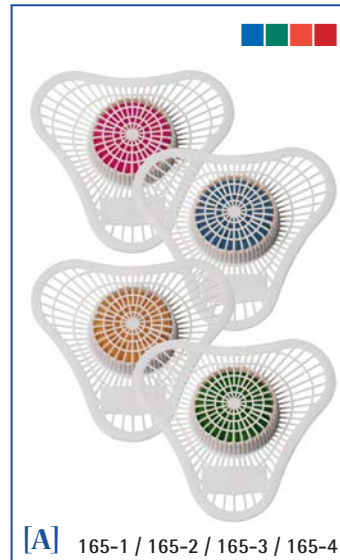

RESTROOM MATS

Kleen Mats will save hundreds of maintenance dollars every year, while providing a safer, more sanitary way to deal with the problems of urine splash and drips around urinals and commodes. Super absorbent material reduces moisture on restroom floors, thereby reducing slippery conditions. Because our product stays where it's put, it presents no safety hazard itself. When scheduled daily maintenance calls for wet mopping, these mats can be mopped over or removed for total floor cleaning.

[D] KLEEN MATS - URINAL MATS

[E] KLEEN MATS - COMMODE MATS

Brand	Item #	Description	Color	Case Pack	Case Weight	Case Cu. Ft.	Stock Item
Continental	167-1	Urinal Mat	Grey	6	6.00 lbs.	0.400	✓
Continental	167-2	Urinal Mat	Black	6	6.00 lbs.	0.400	✓
Continental	168-1	Commode Mat	Grey	6	6.50 lbs.	0.400	✓
Continental	168-2	Commode Mat	Black	6	6.50 lbs.	0.400	✓

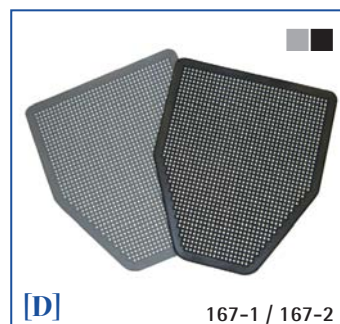

RESTROOM CLEANING TOOLS

Cleanliness is one of the most important factors with customers in restaurants, retail stores and many other public buildings. Encourage repeat business by keeping your restrooms clean and pleasant. We have all the necessities needed to ensure a clean, safe and healthy restroom facility.

[A] RESTROOM VALUE PACK

Kit includes everything you need for thorough restroom cleaning! Red 26 qt. Splash Guard™ Combo, 3 ProSafe™ Sprayers, 1 Breakdown Mop Handle with Adaptor, 1 Red Microfiber Mop, 1 Bowl Mop, 1 Bowl Mop Caddy, 5 Red Supremo™ Microfiber Cloths and 1 Wet Floor Sign.



Brand	Item #	Case Pack	Case Weight	Case Cubic Ft.	Stock Item
Continental	RRVP-1	1	23.90 lbs.	5.150	✓

[B] KLEEN BOWL RIM BASKET

Enzymatic deodorant block contains surfactants and chelating agents to clean and deodorize for up to 1,500 flushes- bluing agents are released with each flush so you know that it's working. Block packed in environmentally safe PVA water-soluble film.



Brand	Item #	Scent	Color	Case Pack	Case Weight	Case Cu. Ft.	Stock Item
Continental	166-1	Floral	Blue	72	13.00 lbs.	0.870	✓

[C] PLUNGER

Unique design for full power. Solid plastic handle, buna rubber bulb.



Brand	Item #	Handle Length	Color	Case Pack	Case Weight	Case Cu. Ft.	Stock Item
Continental	520	24"	Black	12	24.36 lbs.	2.160	✓

[D] CONTOURED BOWL BRUSH



Polypropylene fibers are ideal for light scrubbing of toilet bowls, as well as removing build-up at the water line. Perfect for office and light industrial areas. Also available in an angled plastic handle for easy under rim cleaning. The convenient caddy option stores the straight handled bowl brush. Black fibers with white handle.



Brand	Item #	Description	Bristle Type	Bristle Trim	Material	Overall Length	Color	Case Pack	Case Weight	Case Cu. Ft.	Stock Item
Wilco	J501001	Contoured Bowl Brush	Polypropylene	3 1/2"	Plastic	14"	Black	12	4.00 lbs.	0.590	✓
Wilco	J506000	Contoured Bowl Brush w/Caddy	Polypropylene	3 1/2"	Plastic	14"	Black	12	6.00 lbs.	0.977	✓
Wilco	J503001	Angled Contoured Bowl Brush	Polypropylene	3 1/2"	Plastic	17"	Black	12	3.00 lbs.	0.879	✓
Wilco	J502100	Caddy	- - -	- - -	Plastic	4"	White	12	2.00 lbs.	0.977	✓

RESTROOM CLEANING TOOLS

[A] WIRE BOWL BRUSH

Angled head allows the brush to fit under the rim for thorough scrubbing.



[B] PRO M BOWL MOP

16" contoured plastic handle features a sliding squeeze cup to wring out acrylic puff. Soft scrubbing acrylic is non-absorbent, so it dries quickly.



[C] ECONOMY BOWL MOP

Economical bowl mop with white, 12" plastic handle has a fast-drying, non-absorbent acrylic yarn puff to gently wash porcelain fixtures.



Brand	Item #	Description	Brush Type	Handle Material	Overall Length	Color	Case Pack	Case Weight	Case Cu. Ft.	Stock Item
Wilco	J507017	Wire Bowl Brush	Polypropylene	Wood	20"	Tan	12	5.00 lbs.	1.110	✓
Wilco	WJ509001	Pro M Bowl Mop	Acrylic	Plastic	16"	White	72	8.14 lbs.	1.154	✓
Wilco	WJ510000	Economy Bowl Mop	Acrylic	Plastic	12"	White	144	17.85 lbs.	1.940	✓

[D] SANITARY CADDY

Locking strap adjusts and holds most quart bottles. Plastic hinged lid hides mop and prevents odors and spills. Easily accommodates the WJ510000 Bowl Mop.

Brand	Item #	Size	Color	Case Pack	Case Weight	Case Cu. Ft.	Stock Item
Continental	780	6" x 4" 7 1/2"	White	12	5.04 lbs.	1.200	✓



[E] SANITARY NAPKIN RECEPTACLE

Heavy gauge steel with flip top lid. Door at base makes disposal quick and sanitary. Wax paper liners sold separately.



Brand	Item #	Description	Size	Color	Case Pack	Case Weight	Case Cubic Ft.	Stock Item
Continental	250C	Sanitary Napkin Receptacle	11 3/4" x 8 7/8" x 4 7/16"	Chrome	6	21.96 lbs.	2.040	✓
Continental	250W	Sanitary Napkin Receptacle	11 3/4" x 8 7/8" x 4 7/16"	White	6	21.96 lbs.	2.040	✓
Continental	250K	Wax Paper Receptacle Liners	11 1/4" x 7 1/2" x 3"	Kraft	1/500	8.00 lbs.	0.390	✓



TOWEL & TISSUE DISPENSERS

Our line of dispensers is durable, easy-to-install and easy-to-use. Universal design will work with any paper supplier. Our selection of touchless dispensers allows hygienic, hands-free dispensing, reducing cross-contamination.

[A] MULTI-FOLD TOWEL DISPENSER

Touch-free to reduce the risk of cross-contamination! Dispenses one towel at a time, conserving paper. Compatible with towels up to 9 1/2" x 3 1/2". Includes key lock for security.

[B] CENTER PULL TOWEL CABINET

Self-adjusting nozzle allows smooth towel delivery. Dispenses all common sizes of center pull towels. Fully lockable and easy to load.

[C] LEVER ACTION ROLL TOWEL DISPENSER

Features a long push level for easy use - each push provides 5 1/2" of paper. Automatic transfer feature maximizes capacity with no roll waste.

[D] AUTOMATIC ROLL TOWEL DISPENSER

Touch-free to reduce the risk of cross-contamination! Multiple settings for paper saving, sheet length and time delay. Automatic transfer feature maximizes capacity with no roll waste.

[E] MECHANICAL ROLL TOWEL DISPENSER

Touch-free to reduce the risk of cross-contamination! Automatic transfer feature maximizes capacity with no roll waste.



Brand	Item #	Description	Size	Color	Case Pack	Case Weight	Case Cubic Ft.	Stock Item
Continental	632	Multi-Fold Towel Dispenser	11 1/8" x 16 1/8" x 4 5/8"	Beige/Navy	6	16.19 lbs.	3.472	✓
Continental	633	Center Pull Towel Dispenser	10 1/8" x 12 1/4" x 10 1/8"	Beige/Navy	1	3.14 lbs.	0.854	✓
Continental	676	Lever Action Roll Towel Dispenser	10 1/2" x 15 3/4" x 8 3/4"	Beige/Navy	1	7.13 lbs.	1.172	✓
Continental	677	Automatic Roll Towel Dispenser	12 5/16" x 15 1/4" x 9 1/2"	Beige/Navy	1	5.50 lbs.	1.158	✓
Continental	678	Mechanical Roll Towel Dispenser	12 1/2" x 14 7/8" x 9 3/8"	Beige/Navy	1	5.74 lbs.	1.092	✓

TOWEL & TISSUE DISPENSERS

[A] COMBO TOWEL CABINET

For multi-fold or "C" fold towels. Heavy gauge steel with see through towel gauge and hinged locking cabinet.

[B] PLASTIC COMBO TOWEL CABINET

For multi-fold or "C" fold towels. High-impact plastic cover with steel back. Furnished with lock and key.

[C] SINGLE FOLD TOWEL CABINET

Powder coated enamel or chrome finish are durable and attractive. Features sturdy piano hinge and see through towel gauge for at-a-glance reference. Self-locking cabinet holds two packages of standard single fold towels.

[D] SINGLE FOLD PLASTIC TOWEL CABINET

High-impact plastic cover and back mounting plate. Furnished with lock and key.

[E] ROLL TOWEL CABINET

Dent resistant steel for paper towel rolls. Delivers 17/8" per crank, accommodates 8" width. Up to 500 feet per roll. Sloped design deters accumulation of debris. Furnished with lock and key.



Brand	Item #	Description	Size	Color	Case Pack	Case Weight	Case Cubic Ft.	Stock Item
Continental	989SS	Combo Towel Cabinet	15 ³ / ₈ " x 11 ¹ / ₄ " x 4 ¹ / ₁₆ "	Silver	1	6.38 lbs.	0.550	✓
Continental	990W	Combo Towel Cabinet	15 ³ / ₈ " x 11 ¹ / ₄ " x 4 ¹ / ₁₆ "	White	1	6.51 lbs.	0.550	✓
Continental	991C	Combo Towel Cabinet	15 ³ / ₈ " x 11 ¹ / ₄ " x 4 ¹ / ₁₆ "	Chrome	1	6.43 lbs.	0.550	✓
Continental	992P	Plastic Combo Towel Cabinet	15 ³ / ₈ " x 11 ¹ / ₄ " x 4 ¹ / ₁₆ "	White	1	4.26 lbs.	0.650	✓
Continental	630C	Single Fold Towel Cabinet	7 ¹ / ₂ " x 12 ¹³ / ₁₆ " x 6 ¹ / ₂ "	Chrome	1	4.66 lbs.	0.420	✓
Continental	630W	Single Fold Towel Cabinet	7 ¹ / ₂ " x 12 ¹³ / ₁₆ " x 6 ¹ / ₂ "	White	1	4.66 lbs.	0.420	✓
Continental	631P	Single Fold Plastic Towel Cabinet	9 ¹ / ₄ " x 12 ⁷ / ₁₆ " x 6"	White	1	2.88 lbs.	0.530	✓
Continental	675	Roll Towel Cabinet	10 ⁷ / ₈ " x 9 ³ / ₄ " x 6 ³ / ₄ "	White	1	7.95 lbs.	0.620	✓

TOWEL & TISSUE DISPENSERS

[A] SINGLE 9" JUMBO ROLL DISPENSER

Dispenses 9" diameter rolls with standard cores. Front cover is translucent for easy supply check. Accommodates all popular Jumbo Roll tissue widths.

[B] JUMBO 9" W/STUB ROLL DISPENSER

Movable mandrel allows use as a 12" JBT dispenser. Front cover is translucent for easy supply check. Allows for increased capacity without stub roll waste.

[C] TWIN 9" JUMBO ROLL DISPENSER

Perfect for high traffic areas. Front cover is translucent for easy supply check. Accommodates all popular Jumbo Roll tissue widths.

[D] TWO ROLL TISSUE DISPENSER

Tissue is easy to access. Compact design allows this dispenser to fit in tight places. Lockable to prevent theft.

[E] DELUXE TISSUE HOLDER

Zinc die cast bright chrome finish, concealed hinge button behind roll, tension spring controls tissue flow. Single or double roll capacity.

[F] CLASSIC ROLL TISSUE HOLDER

Pilfer-proof locking device with brake spring action. Bright chrome finish. Single or double roll capacity.

[G] DUET DISPENSER

Covered storage roll, dent resistant steel, hinged door lock. Holds two 1,500 sheet rolls.

[H] COMBINATION TISSUE CABINET

Dent resistant steel for single or double fold tissue, see through gauge. Key lock.

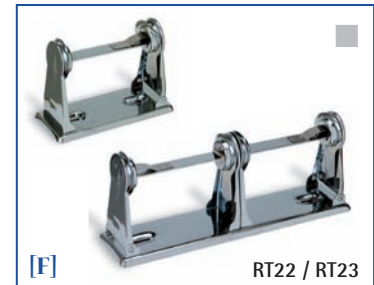
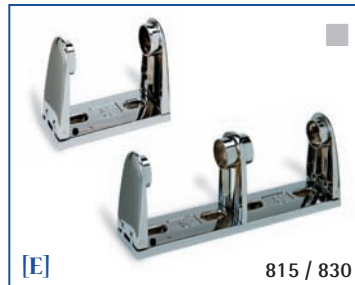

Brand	Item #	Description	Size	Color	Case Pack	Case Weight	Case Cu. Ft.	Stock Item
Continental	840	Single 9" Jumbo Roll Dispenser	11 ³ / ₈ " x 11 ³ / ₈ " x 5 ³ / ₈ "	Beige/Navy	6	16.14 lbs.	3.041	✓
Continental	841	Single 9" w/Stub Jumbo Roll Dispenser	16 ⁵ / ₈ " x 14 ⁷ / ₁₆ " x 5"	Beige/Navy	4	14.41 lbs.	3.294	✓
Continental	842	Twin 9" Jumbo Roll Dispenser	20 ¹ / ₄ " x 11 ³ / ₈ " x 5 ³ / ₈ "	Beige/Navy	4	17.75 lbs.	3.801	✓
Continental	877	Two Roll Tissue Dispenser	6 ¹ / ₁₆ " x 13" x 6 ³ / ₁₆ "	Beige/Navy	6	7.50 lbs.	2.218	✓
Continental	815	Deluxe Tissue Holder - Single	2 ⁷ / ₁₆ " x 5 ¹ / ₂ " x 4 ⁵ / ₁₆ "	Chrome	12	14.04 lbs.	0.600	✓
Continental	830	Deluxe Tissue Holder - Double	12 ⁷ / ₁₆ " x 10 ¹ / ₂ " x 4 ⁵ / ₁₆ "	Chrome	12	21.72 lbs.	0.960	✓
Continental	RT22	Classic Roll Tissue Holder - Single	2 ³ / ₄ " x 6" x 4 ¹ / ₄ "	Chrome	12	9.48 lbs.	0.720	✓
Continental	RT23	Classic Roll Tissue Holder - Double	2 ³ / ₄ " x 11" x 4 ¹ / ₄ "	Chrome	12	17.52 lbs.	1.200	✓
Continental	876C	Duet Dispenser	11 ³ / ₈ " x 11 ³ / ₈ " x 5 ³ / ₈ "	Chrome	12	5.18 lbs.	0.420	✓
Continental	401SD	Combination Tissue Cabinet	6" x 10" x 5 ¹¹ / ₁₆ "	White	12	18.60 lbs.	1.080	✓

SOAP DISPENSERS

We offer several soap dispensers to round out our restroom cleaning product line. These standard, easy-to-install dispensers offer a variety of styles and sizes.

[A] BULK SOAP DISPENSER

Large push button is ADA compliant, when properly installed. Dispenses 1cc per stroke.

[B] KLEEN HANDS SOAP DISPENSER

With large push button actuation and five pound ergonomic push spring, this dispenser meets the ADA standards for use. The Kleen Hands Dispenser has a removable 27 ounce refillable reservoir, allowing units to be filled without the use of a funnel. Dispenses 2.2cc per stroke, handling a wide range of viscosities. External sight glass allows user to check the soap level at a glance. Sloped top and ABS body prevents cigarette burns and vandalism.

[C] ROUND SOAP DISPENSER

Tamper and theft proof, top fill with service key. Plastic reservoir.

[D] POWDER SOAP DISPENSER

One hand delivery, vandal proof. Large 4" top fill opens with service key. Chrome plated steel.

[E] RECTANGULAR SOAP DISPENSERS

Tamper and theft proof. See through gauge and top fill with service key, for soaps, detergents or lotions. Stainless Steel. Horizontal - V333SS / Vertical - V444SS.

[F] ALL PURPOSE SOAP DISPENSER

Oblong plastic tank, pump action dispenser for liquid lotion and synthetic detergents.

[G] LIQUID SOAP DISPENSER

Gravity feed with replaceable metal valve and plastic globe.



Brand	Item #	Description	Reservoir Capacity	Size	Color	Case Pack	Case Weight	Case Cu. Ft.	Stock Item
Continental	721	Bulk Soap Dispenser	46 oz.	5 1/4" x 8 1/2" x 4 1/4"	White/Navy	12	15.32 lbs.	1.849	✓
Continental	260	Kleen Hands Soap Dispenser	27 oz.	9 1/4" x 4 15/16" x 3 3/4"	White	1	1.64 lbs.	0.150	✓
Continental	711	Round Soap Dispenser	12 oz.	6 3/4" x 3 1/16" x 6"	Chrome	24	4.66 lbs.	0.420	✓
Continental	701	Powder Soap Dispenser	1 qt.	7 1/8" x 4 7/16" x 4 5/8"	Chrome	6	9.36 lbs.	0.660	✓
Continental	V444SS	Vertical - All Purpose Soap Dispenser	40 oz.	8 3/16" x 4 13/16" x 2 1/16"	Steel	6	11.76 lbs.	1.140	✓
Continental	H333SS	Horizontal - All Purpose Soap Dispenser	40 oz.	4 13/16" x 8 3/16" x 2 1/16"	Steel	6	11.76 lbs.	1.140	✓
Continental	706	All Purpose Soap Dispenser	16 oz.	6 3/4" x 3 1/4" x 5 1/8"	Steel	6	6.24 lbs.	0.600	✓
Continental	LD501	Liquid Soap Dispenser	16 oz.	2 3/4" x 11" x 4 1/4"	Steel	6	9.02 lbs.	0.810	✓



INFANT CARE

Our baby changing stations are safe, versatile and compliant with applicable regulations. They feature easy-to-clean surfaces, non-absorbent safety straps, bag hooks, dual liner dispensers and pneumatic shocks that allow one hand opening and closing.

Continental Commercial Products is pleased to introduce an expanded line of Infant Care Products. All products are A.D.A. compliant when properly installed. Changing Stations are available in either Horizontal or Vertical style to meet size and space requirements. The expanded line features a Child Safety Seat that can be either wall or partition-mounted.

[A] DIAPER CHANGING STATION

The concave shelf design provides a deep area for the child to lay, preventing them from rolling around. Heavy-duty safety straps provide an additional level of child security. Safety belt with cam-buckle is adjustable with one hand for safety and convenience, belt is non-absorbent. *Designed to hold a static load of 250 lbs., with little or no deflection.

Derma-Tek® high-density polyethylene naturally inhibits bacterial growth (tested to ASTM G21 Anti-Bacterial and ASTM G22 Anti-Fungal), which provides a safe, convenient and hygienic platform. Easy to read ANSI compliant labels (ANSI Z535.3 and ANSI Z535.4). Plastic lined bed liners create a barrier between your child and the changer. Liners unfold to 13" x 18". Molded-in, dual liner dispensers will each accommodate approximately 50 bed liners.

Designed for easy mounting, the molded-in hang holes allow the unit to be attached to the standard 16" on-center studs, or hung on a hollow wall - all required hardware is included. Concealed rear pneumatic strut provides smooth opening/closing power while concealed hardware maintains appearance and prevents tampering.

Each Horizontal and Vertical changer comes with a self-adhesive placard for the rest room door, to indicate a changer is located inside.

[B] CHILD'S SAFETY SEAT

The Child's Safety Seat provides a means for keeping a child safely off the rest room floor. Unit folds flat so it's out of the way when not in use, and the three point safety harness and concave seat area secures a child, freeing your hands. ADA Compliant when properly installed.



Brand	Item #	Description	Size	Color	Case Pack	Case Weight	Case Cubic Ft.	Stock Item
Continental	8252-H	Horizontal Changing Station	34 1/4" x 4" x 18"	White	1	16.20 lbs.	1.730	✓
Continental	8252-V	Vertical Changing Station	19" x 4" x 34"	White	1	22.70 lbs.	2.170	✓
Continental	8255	Liners	4 3/4" x 6 1/2" (folded)	White	500	8.20 lbs.	0.940	✓
Continental	8254	Child's Safety Seat	12" x 3" x 15 1/4"	White	1	5.50 lbs.	0.490	✓

To compliment our Infant Care products, see page 102 for our line of Step-On trash receptacles - perfect for diaper disposal!

Alphabetical Index

A

Action Pro® Wet Mop	12
Absorbo™ Wet Mop	12
Aggressor™ Mop	24
Aqua Floor Pads	61, 62
Ash Top Receptacles	100

B

BackSaver Huskee®	95
Barrier Chain	29
Bathroom Products	123-132
Baby Diaper Changing Stations	132
Odor Control	123-124
Kleen Aire™ Cabinets	124
Kleen Aire™ Carpet & Room Deoderizer	124
Kleen Aire™ Instant Absorbent	124
Kleen Aire™ Neutralizer Gels	124
Kleen Aire™ Wick Air Freshener	124
Kleen Bowl	
Automatic Toilet Bowl Cleaner	124
Kleen Tech™ Aerosol Scents	123
Kleen Tech™ Aerosol Dispensers	123
Restroom Value Pack, Cleaning	126
Sanitary Caddy	127
Sanitary Napkin Receptacle	127
Soap Dispensers	131
Towel & Tissue Dispensers	128-130
Toilet Products	126-127
Contoured Bowl Brush	126
Economy Bowl Mop	127
Kleen Bowl Rim Basket	126
Plunger	126
Pro M Bowl Mop	127
Wire Bowl Brush	127
Urinal Mats & Screens	125
Clean Screen Urinal Screen	125
Contoured Urinal Screen	125
Deod-O-Screen	125
Kleen Mats	125
Beige Floor Pads	61, 62
Black Stripping Floor Pads	56, 58
Blue Cleaning Floor Pads	56, 59
Blue Ice Floor Pads	61, 62
Break-A-Way Mop Handle	19
Brillo® Pads	80
Brown Stripping Floor Pads	56, 58
Brooms	44-50
Angle Brooms	45
Corn and Corn Blend Brooms	44
Handles	51-52
Lobby Brooms	44
Poles	51-52
Sweeps, About	46

Sweeps, Floor	47-48
Sweeps, Garage	49
Sweeps, Patio & Ground	50
Brushes & Scrubs	80-84
Baseboard Brush	82
Deck Brushes	82
Floor Scrubs	82
Glass Washer Brushes	84
Hand & Nail Brush	84
Radiator Brush	80
Scrub Brushes	80-81
Vehicle Brushes	83
Wire Brushes	83
Buckaroo Floor Pads	61, 64
Buckets	22, 88-89
Huskee® Bucket	88
"Broken Glass" Huskee® Bucket	88
"Sanitizer" Huskee® Bucket	88
Huskee® Divided Pail	89
Huskee® Hauler	89
Solution Bucket	22
Squeegee Bucket	89
Buckets & Wringers – Mops	3-5
26 Qt. Splash Guard™ Combo Pack	4
26 Qt. Splash Guard™ Mop Bucket	4
35 Qt. Splash Guard™ BackSaver Combo Pack	5
35 Qt. Splash Guard™ Combo Pack	5
35 Qt. Splash Guard™ Mop Bucket	4
44 Qt. Structolene™ Combo Pack	5
44 Qt. Structolene™ Mop Bucket	4
Down-Press Wringer	3
Institutional Wringer	3
Institutional Wringer Combo	4
Smoothline Combo Pack	5
Splash Guard™ Side-Press Wringer	3
Unibody™ Mopping System	4
Wringers	4-5
Buffing Floor Pads	60
Bulldog Mop™	11
Burnishing Floor Pads	62-65
Bussing Carts	115
Buss Tubs	116
California Wet Mop	15
Carpet Bonnets	73-74
Microfiber Deep Scrub	74
Microfiber Dry Polish	74
King Bonnet	73
King Cotton Bonnet	73
Prince Bonnet	74
Queen Bonnet	73
Queen Mitt	74

C

Carts & Accessories	31-32, 113-116
Bussing Carts	115
Buss Tubs	116
Folding Carts	114
Janitor Carts	31-32
Compact Cleaning Cart	31
Convertible Janitor Cart	32
Janitors' Cart	31
Janitor Cart Accessories	32
Port-A-Cart	32
Zippered Bag	32
Hand Truck	115
Lodging Carts	113
Maid Carriers	114
Replacement Bags	114
Silverware & Refuse Bins	116
Utility Carts	115
X-Frame Carts	114
Cellulose Sponges	77
Champagne Floor Pads	61, 63
Charger Disposable Dust Mop	40
Chemical Free Stripping Pads	56, 58
Choice™ Wet Mops	15
Cleaning Floor Pads	59
Cobweb Duster	86
CoCoPad® Floor Pads	61, 65
Collapsible Safety Cones	30
Color-Code-It Hand Pads	79
Color Guard® Mop Handle	18
Colossus® Receptacles	98-99, 109
Ash Tray Top	98
Colossus® Receptacle, Four Door	98
Colossus® Receptacle, Two Door	98
Colossus® Recycling Station	109
Plastic Liner	98
Tray Top	98
Weighted Base	98
Conventional, Low Speed Floor Pads	56-60
Coral Multipurpose Pads	56, 59
Corn Brooms	44
Corner Round™ & Dolly	100
Counter Duster	87
Crisper Bin	119
Cube Trucks	112, 122-123
Cyclone™ & Cyclone-D™ Stone Care	68-71

D

Deck Brushes	82
Deod-O-Screen	125
Diaper Changing Stations	132
Dollies	96, 97, 100, 103, 109, 110

Down-Press Wringers	3
Drop Shot Lid	105
Drum Pumps	91
Dunnage Racks	118
Duraloop Mop	13, 26
Durastat™ Dust Mop	36
Dusting	85-87
Dusters, Microfiber	86
Dusting Cloths, Microfiber	85
Dusting Mitt, Heavy Duty	87
Magna Thirsty Towel	87
Microflex™ Duster	86
Treated Dust Cloth	87
Wall Washer, Duster	88
Dust Mops	33-41
Adaptor for Dust Mops	39, 41
Durastat™	36
Dust Mops, Application Guide	33
Dust Mops, Microfiber	39-40
E-Line Tie Free™	37
Jean Clean™ Disposable Dust Mop	38
Permaloop™	36
Permatwist™	35
Roll-Out™ Disposable	38
Swivel Snap™	36
Tie Free™	37
Triangle	38
Twister Loop™	35
Value Line™	37
Dust Mop Handles & Frames	41-42
Stick-M™ Holder	42
Swivel Snap™ Frames	41
Swivel Snap™ Handles	41
Wear-Ever™ Plastic Frame	42
Dust Pans	42-43

E

E-Line Finish Mops	14
Emerald Floor Pads	56, 57
ErgoFlo™ Mop Handle	27
Ergoworx® Touchless Mopping System	23

F

Fantastic™ Mops	8
FastTrack™ Finish Mops	14
Flat Top Receptacles	100
Floor Finish Applicator	22
Floor Finish Mops	13-14, 22
Floor Pads	53-74
Application Guide	53-55
Burnishing Pads	62-65
Carpet Bonnets	73-74
King Bonnet	73

King Cotton Bonnet	73
Microfiber Deep Scrub	74
Microfiber Dry Polish	74
Prince Bonnet	74
Queen Bonnet	73
Queen Mitt	74
Cleaning Pads	59-60
Conventional, Low Speed Pads	56-60
Black Stripping	58
Blue Cleaning	59
Brown Stripping	58
Chemical Free, Green Stripping	58
Coral, Multi-Purpose	59
Green Scrubbing	59
Emerald II Stripping	57
Red Spray Buffing	60
Safire Stripping	57
Tan Buff Polishing	60
White Super Polishing	60
Cyclone™ and Cyclone-D™	68-71
Diamond Pads, Cyclone-D™	69
Environmentally Friendly Pads	53
Kleenfast® Pads & Holders	67
Microfiber Pads	74
Multi-Purpose Coral Pad	59
Natural Hair Pads	64
Polishing Pads	60
Sand Screen Pads	72-73
Sand Screen Pad Driver	71
Scrubbing Pads	59
Stone Care Chemicals	71
Stone Care Pads	68-71
Stripping Boots	68
Stripping -Chemical Free	58
Stripping Pads	57-58
Ultra High Speed Burnishing	61-65
100-D Neutral Poly Thermal	65
Aqua Burnishing	62
Beige Burnishing	62
Blue Ice Burnishing	62
Buckaroo® Natural Hair	64
Champagne Burnishing	63
CocoPad® Natural Hair	65
Jackeroo® Lite Natural Hair	64
Jackeroo® Natural Hair	64
Joey Burnishing	62
Peach Burnishing	65
Tan Burnishing	63
Wood Floor Pads, Maroon	66
Usage Tips	54
Utility Pads & Holders	67-68

Floor Signs	29-30
Floor Squeegees	28
Metal Floor Squeegees	28
Plastic Floor Squeegees	28
Floor Sweepers	42
Floor Sweeps	48
Folding Carts	114

Food Service Equipment	84, 113-121
Bussing Carts	115
Buss Tubs	116
Crisper Bin	119
Dunnage Racks	118
Glass Washer Brushes	84
Ice Bins	119
Ice Bins, Huskee® "Ice Only"	120
Ingredient Bins	118
Lodging Carts	113
Measures	120
Pitchers	121
Scoops	120
Silverware & Refuse Bins	116
Storage Shelves	117
Utility Carts	115
Funnel Top Receptacles	101

G

Garage Sweeps	49
General Purpose Looped-End Wet Mops	11
Glass Washer Brushes	84
Glassic Microfiber Cloths	85
Go Go™ Mops	15-16

H

Handles & Poles	51-52
Hangers for Handles	52
Metal Threaded Wood Handle	51
Plastic Threaded Fiberglass Handle	51
Telescopic Poles	52
Wood, Threaded & Tapered	51
Handles, Mops	
3 Piece Microfiber Handles & Stirrup Head Adaptor	27
#94 Speed Change™	18
Break-A-Way	19
Bucketless Mop Handle, ErgoFlo™	27
Color Guard™	18
Dust Mop Handles & Frames	41-42
ErgoFlo™ Mop Handle	27
ErgoWorx® Touchless Mopping	23
ErgoWorx® Touchless Mopping Starter Kits	23
Jaws	19
Load 'N Lock™	18
Metal Stirrup Quick Change™	20
Microfiber Mop Frames & Handles	26-27
Pinnacle™	20
Pro II Flat Mop Frame, Microfiber	27
Night Stick	19
Sponge Mop Handles	21
Spring Yoke	20
Stick-M™ Holder	42
Stirrup Head Adaptor	27
SuperJaws™	19
SureGrip™	20

Swivel Snap™ Handles	41
Wet Mop Handles	18-20
Hand & Nail Brush	84
Hand Pads & Sponges	75-80
Hand Pads	77-80
Blue WalnutPad®	78
Color Code It Pads	79
Light Wipe - White	77
Industrial Hand Pads	79
Pot & Pan Scrubber - Blue	77
Scouring Pad, Heavy-Duty Dark Green	78
Scouring Pad, Light Duty White	78
Scouring Pad, Medium Duty Green	78
Steel Wool Soap Pads	80
WalnutPad®	78
Sponges	75-77
Blue WalnutPad® SpongePro™	75
Blue WalnutPad® Sponge N' Scrubber	76
Cellulose Sponges	76-77
Light Duty Sponge N' Scrubber	77
Light Duty SpongePro™	76
Medium-Duty Sponge N' Scrubber	77
Medium-Duty SpongePro™	76
WalnutPad® Sponge N' Scrubber	76
WalnutPad® SpongePro™	75
WipeClean Pro™ Sponge	76
Hand Truck	115
Hospital Pro M™ Mops	9
Housekeeping Carts	113, 114
Huskee® Receptacles	93-97, 108
Caddy Bag for Huskee®	95
Dolly, Huskee® Round	96
Dolly, Huskee® Square	97
Huskee® Backsaver	95
Huskee® Round	93-94
Huskee® Round "Indelible"	94
Huskee® Square	97
Lids, Huskee® Round	94, 96
Lids, Huskee® Square	97
Maid Caddy for Huskee®	95
SuperKan®	95
I	
Ice Bins	119-120
Ingredient Bins	118
Industrial Hand Pads	79
Institutional Combos	4
Institutional Wringer	3
J	
Jackeroo® Floor Pads	61, 64
Jackeroo® Lite Floor Pads	61, 64
Janitor Carts	31-32
Compact Cleaning Cart	31

Convertible Janitor Cart	32
Janitors' Cart	31
Janitor Cart Accessories	32
Port-A-Cart	32
Zippered Bag	32
Jaws Mop Handle	19
Jean Clean™ Mops	10
Jean Clean™ Disposable Dust Mop	38
Joey® Floor Pads	61, 62
J. W. Atomic™ Mops	10
J. W. Atomic™ Finish Mops	14
K	
King™ Bonnets	73
King Kan®	99
King Kan® Leg Kit	99
King Kan® Poly Bag	99
King Kan® Receptacles	99
King Kan® Rigid Plastic Liner	99
Kleen Aire™ Odor Control Products	124
Kleen Bowl Automatic Toilet Bowl Cleaner	124
Kleenfast® Pads & Holders	67
Kleen Tech™ Odor Control Products	123
L	
Lids	
Drop Shot	105
Huskee® Round	94, 96
Huskee® Square	97
Recycling Huskee®	
Dome with Holes	108
Recycling Huskee® with Holes	108
Recycling Swingline	111
Recycling Tip Top	111
Recycle Wall Hugger™	110
Swing Top	105
Tip Top	105
Wall Hugger™	103
Load 'N Lock™ Handle	18
Lobby Brooms	44
Lock-On Warning Sign	29
Lodging Carts	113
M	
Magna Thirsty Towel	87
Maid Carriers	114
Maroon Floor Pads	66
Material Handling	121-123
Platform Trucks	121
Tilt Trucks	122-123

Measures	120
Pitchers	121
Metal Stirrup Handle	20
Microfiber Products	
Cloths, Microfiber	85
Dusters, Microfiber	86
Dusting Mitt, Heavy Duty	87
Dust Mops, Microfiber	39-40
Floor Pads	74
Classic™	85
Microflex™ Duster	86
Mops, Microfiber	24-26, 39-40
Standard Cloths	85
Squeegee, Plastic Microtiger Complete	92
Supremo™ Cloths	85
Supremo™ Duster	86
Mop Buckets & Wringers	3-5
26 Qt. Splash Guard™ Combo Pack	4
26 Qt. Splash Guard™ Mop Bucket	4
35 Qt. Splash Guard™ BackSaver Combo Pack	5
35 Qt. Splash Guard™ Combo Pack	5
35 Qt. Splash Guard™ Mop Bucket	4
44 Qt. Structolene™ Combo Pack	5
44 Qt. Structolene™ Mop Bucket	4
Down-Press Wringer	3
Institutional Wringer	3
Institutional Wringer Combo	4
Smoothline Combo Pack	5
Splash Guard™ Side-Press Wringer	3
Unibody™ Mopping System	4
Wringers	4-5
Mops	
Dust Mops	34-40
Adaptor for Dust Mops	39, 41
Application Guide, Dust Mops	33
Charger™	40
Durastat™	36
Duster, The	40
E-Line Tie Free™	37
Jean Clean™ Disposable Dust Mop	38
Microfiber	39-40
Permaloop™	36
Permatwist™	35
Roll-Out™ Disposable	38
Swivel Snap™	36
Tie Free™	37
Triangle	38
Twister Loop™	35
Value Line™	37
Microfiber Mops	24-26, 39
Aggressor™	24
DuraLoop Wet	13, 26
Super Pro™ II Microfiber	25
Super Pro™ Finish Flat Mop	24
Super Sorb Tube Microfiber	13, 26
Wet Mops	6-17, 24-26
Action Pro™	12

Absorbo™	12	Stirrup Head Adapter	27	Sprayers, High Output	90
Application Guide, Wet Mops	6-7	SuperJaws™	19	Spray-Pro Sprayers	90
Bulldog Mop™	11	SureGrip™	20	Tank Sprayers, Huskee Tank Sprayer	90
California	15	Swivel Snap™ Frames	41		
Choice™	15	Swivel Snap™ Handles	41	Q	
Cotton- See Wet Mop Application Guide	6-7	Touchless Mopping System	23	Quad-Cone System	29
Cut End	15-17	Wear-Ever™ Plastic Frame	42	Quad-Cones	29
DuraLoop Wet	13, 26	Wet Mop Handles	18-20	Queen™ Bonnets	73
Economy	11	Mops – Touchless Mopping System	23	Queen™ Mitt	74
E-Line Finish	14	ErgoWorx® Touchless Mopping	23		
Fantastic™	8	ErgoWorx® Touchless Mopping	23	R	
FastTrack™ Finish	14	Starter Kits	23	Radiator Brush	80
Floor Finish	13-14			Receptacles	93-112
General Purpose Looped-End	11	N		Ash Top	100
Go Go™	15	Natural Hair Floor Pads	64-65	Colossus® Line	98-99, 109
Go Go™ Blend	15-16	Night Stick Mop Handle	19	Ash Tray Top	98
Hospital Pro M™	9	NSF® Ventilated Storage Shelves	117	Colossus® Receptacle, Four Door	98
Industrial	15			Colossus® Receptacle, Two Door	98
Jean Clean™	10	O		Colossus® Recycling Station	109
J. W. Atomic™	10	Odor Control	123-124	Tray Top	98
J. W. Atomic™ Finish	14	Kleen Aire™ Cabinets	124	Weighted Base	98
Laundry Net	17	Kleen Aire™ Carpet & Room Deoderizer	124	Corner Round™ & Dolly	100, 109
Looped End	8-14	Kleen Aire™ Instant Absorbent	124	Flat Top	100
MuscleMop™	13	Kleen Aire™ Neutralizer Gels	124	Funnel Top	101
MusclePro™	12	Kleen Aire™ Wick Air Freshener	124	Huskee® Line	94-97, 108
Pinnacle™	17	Kleen Bowl Automatic Toilet Bowl Cleaner	124	Caddy Bag for Huskee®	95
Rough Rider	12	Kleen Tech™ Aerosol Scents	123	Dolly, Huskee® Round	96
Smoothie™ Finish	13	Kleen Tech™ Aerosol Dispensers	123	Dolly, Huskee® Square	97
Sponge	21	P		Huskee® BackSaver	95
Specialty Wet Mops	12-13	Pad Driver	73	Huskee® Round	93-94
Stinger	15	Pails	89	Huskee® Round "Indelible"	94
Super Crown™	10	Permaloop™ Dust Mop	36	Huskee® Round Recycling	108
Super Looper™	11	Permatwist™ Dust Mop	35	Huskee® Square	97
Super Sorb Tube Mop	13	Pinnacle™ Handle	20	Huskee® Square Recycling	108
Synthetic-See Wet Mop Application Guide	6-7	Pinnacle™ Mops	17	Lids, Huskee® Round	94, 96, 108
Texray	15	Pipe Duster	86	Lids, Huskee® Square	97
Yacht	17	Pitchers	121	Maid Caddy for Huskee®	95
		Platform Trucks	121	SuperKan®	95
		Polishing Floor Pads	60	King Kan®	99
		Plunger	126	RounTop™	101
		Poles & Handles	51-52	RounTop™ Design Line	102
		Hangers for Handles	52	Smoking Receptacles	107
		Metal Threaded Wood Handle	51	Step-On, Hands Free Receptacle	102
		Plastic Threaded Fiberglass Handle	51	Tilt-N-Wheel®	99, 112
		Telescopic Poles	52	Wall Hugger™ Line	103-104, 110-111
		Wood, Threaded & Tapered	51	Dollies	103, 110
		Pro M Bowl Mop	127	Lids, Recycle Wall Hugger™	110
		ProSafe™ Sprayer	89	Lids, Wall Hugger™	103
		Pumps & Sprayers	89-91	Mounting Bracket	104, 110
		Drum Pumps	91	Recycle Wall Huggers™	110
		Plastic Bottles	90	Wall Hugger™ Half Round	104
		ProSafe™ Sprayer	89	Wall Hugger™ with Handles	103
				Wall Hugger™ without Handles	103
				Wastebaskets	105-106
				Commercial Plastic	106
				Lid, Drop Shot	105
				Lid, Swing Top	105
				Lid, Tip Top	105

Steeline™	106
Swingline™	104
UL Classified	105

Recycling Receptacle Products . . . 108-112

Colossus® Recycling Station	109
Commercial Wastebasket	111
Corner Round™ Recycling Station	109
Cube Truck Recycling	112
Curbside Bin	112
Dolly, Corner Round™	109
Dolly, Wall Hugger™	110
Huskee® Round	108
Huskee® Square	108
Lid, Huskee® Dome with Holes	108
Lid, Huskee® with Hole	108
Lid, Swingline Recycling	111
Lid, Tip Top Recycling	111
Lid, Wall Hugger™ Recycling	110
Swingline™ Recycling	111
Tilt-N-Wheel Recycling	112
Tilt Truck Recycling	112
Wall Hugger™	
Half Round Recycling Receptacles	111
Wall Hugger™ Recycling Receptacles	110

Red Floor Pads . . . 56, 60

Restroom Products . . . 123-132

Baby Diaper Changing Stations	132
Odor Control	123-124
Kleen Aire™ Cabinets	124
Kleen Aire™	
Carpet & Room Deoderizer	124
Kleen Aire™ Instant Absorbent	124
Kleen Aire™ Neutralizer Gels	124
Kleen Aire™ Wick Air Freshener	124
Kleen Bowl	
Automatic Toilet Bowl Cleaner	124
Kleen Tech™ Aerosol Scents	123
Kleen Tech™ Aerosol Dispensers	123
Restroom Value Pack, Cleaning	126
Sanitary Caddy	127
Sanitary Napkin Receptacle	127
Soap Dispensers	131
Towel & Tissue Dispensers	128-130
Toilet Products	126-127
Contoured Bowl Brush	126
Economy Bowl Mop	127
Kleen Bowl Rim Basket	126
Plunger	126
Pro M Bowl Mop	127
Wire Bowl Brush	127
Urinal Mats & Screens	125
Contoured Urinal Screen	125
Deod-O-Screen	125
Kleen Mats	125
Kleen Screen Urinal Screen	125

Ring Weight . . . 30

Rollout Disposable Mop . . . 38

Rough Rider™ Wet Mops . . . 12

S

Safire® Floor Pads	56, 57
Sand Screen Floor Pads	72-73
Scoops	120
Scouring Pads	78-80
Scrapers	93
Scrubs & Brushes	80-84
Baseboard Brush	82
Deck Brushes	82
Floor Scrubs	82
Glass Washer Brushes	84
Hand & Nail Brush	84
Radiator Brush	80
Scrub Brushes	80-81
Vehicle Brushes	83
Wire Brushes	83
Scrubbing Floor Pads	59
Scrub Brushes	80-81
Side-Press Wringers	3
Silverware & Refuse Bins	116
Smoking Receptacles	107
Smoothie™ Finish Mops	13
Smoothline Combo	5
Soap Dispensers	131
Solution Bucket	22
Splash Guard™ Buckets	4
Splash Guard™ Combos	4-5
Splash Guard™ Wringers	3
Sprayers & Pumps	89-91
Drum Pumps	91
Plastic Bottles	90
ProSafe™ Sprayer	89
Sprayers, High Output	90
Spray-Pro Sprayers	90
Tank Sprayers, Huskee Tank Sprayer	90
Sponge Mops	21
SpongePro™	75-77
Sponges	75-77
Spring Yoke Mop Handle	20
Squeegees, Floor	28
Metal Floor Squeegees	28
Plastic Floor Squeegees	28
Squeegees, Windows	91-93
Brass Squeegee Complete	91
Microfiber, Plastic Microtiger Complete	92
Plastic Squeegee Complete	92
Replacement Rubber Blades	92
Scrapers	93
Stainless Steel Squeegee Complete	92
Steel Wool Soap Pads	80

Steeline™ Wastebaskets	106
Step Stool	117
Step-On, Hands Free Receptacle	102
Stick-M™ Holder	42
Stinger Mops	15
Stone Care Pads	68-71
Storage Shelves	117
NSF® Ventilated	117
Structro Tuff®	117
Ventilated	117
Street Sweeps	50
Stripping Boots	68
Stripping Floor Pads	57-58
Structolene® Combo	5
Structolene® Mop Bucket	4
SuperKan®	95
Super Crown™ Mops	9
Super Looper™ Mops	11
Super Pro II Mops	25
Super Sorb Tube Mop	26
Supremo Microfiber Cloths	85
SureGrip™ Handle	20
Sweeps	46-50
Sweeps, Floor	47-48
Sweeps, Garage	49
Sweeps, Patio & Ground	50
Sweepers, Floor	42
Swing Top Lid	105
Swingline™ Wastebaskets	104
Swivel Snap™ Dust Mop	36
Swivel Snap™ Handle	41

T

Tan Floor Pads	61, 63
Telescopic Poles	52
Texray Mops	15
Tie-Free® Disposable Dust Mop	37
Tilt-N-Wheel®	99, 112
Tilt Trucks	122-123
Tip Top Lid	105
Toilet Products	126-127
Contoured Bowl Brush	126
Economy Bowl Mop	127
Kleen Bowl Rim Basket	126
Plunger	126
Pro M Bowl Mop	127
Wire Bowl Brush	127
Urinal Mats & Screens	125
Tool Hangers	52

Touchless Mopping System, ErgoWorx® . . . 23
Triangle Dust Mop 38

U

UL Classified Wastebaskets 105
UHS Floor Pads 61-65
Unibody™ Mopping System 4
Urinal Mats & Screens 125
 Clean Screen Urinal Screen 125
 Contoured Urinal Screen 125
 Deod-O-Screen 125
 Kleen Mats 125
Utility Carts 115
Utility Handles 51

V

Value Line™ Dust Mops 37
Vehicle Brushes 83
Velcro® Adaptor 39
Ventilated Storage Shelves 117

W

Wall Hugger™ Line 103-104, 110-111
 Dollies 103, 110
 Lids, Recycle Wall Hugger™ 110
 Lids, Wall Hugger™ 103

 Mounting Bracket 104, 110
 Recycle Wall Huggers™ 110
 Wall Hugger™ Half Round 104
 Wall Hugger™ with Handles 103
 Wall Hugger™ without Handles 103

Wall Washers 88

WalnutPads® 75-79

 Blue WalnutPad® 78
 Color-Code-It WalnutPad® 79
 Blue WalnutPad® SpongePro™ 75
 Blue WalnutPad® Sponge N' Scrubber 76
 WalnutPad® 78
 WalnutPad® Sponge N' Scrubber 76
 WalnutPad® SpongePro™ 75

Wastebaskets 105-106

 Commercial Plastic 106
 Lid, Drop Shot 105
 Lid, Swing Top 105
 Lid, Tip Top 105
 Steeline™ 106
 Swingline™ 104
 UL Classified 105

Wax-O-Matic® 22

Wet Floor Signs 30

Window Squeegees 91-93

 Brass Squeegee Complete 91
 Microfiber, Plastic Microtiger Complete 92
 Plastic Squeegee Complete 92

 Replacement Rubber Blades 92
 Scrapers 93
 Stainless Steel Squeegee Complete 92

WipeClean Pro™ 76

Wire Brushes 83

Wringers 3-5

 26 Qt. Splash Guard™ Combo Pack 4
 35 Qt. Splash Guard™
 BackSaver Combo Pack 5
 35 Qt. Splash Guard™ Combo Pack 5
 44 Qt. Structolene™ Combo Pack 5
 Institutional Wringer 3
 Institutional Wringer Combo 4
 Smoothline Combo Pack 5
 Splash Guard™ Side-Press Wringer 3
 Unibody™ Mopping System 4

X

X-Frame Carts 114

Y

Yacht Mops 17

Z

Zippered Bag, Janitor's Cart 32

Numeric Index

8BE..... 102	154..... 124	335-39YW..... 5	808L..... 43	1305BN..... 101
8RD..... 102	160A..... 125	335-312BL..... 4	815..... 130	1305BNS..... 102
8WH..... 102	164-1..... 125	335-312BZ..... 4	825..... 43	1305GY..... 101
10BC..... 91	164-2..... 125	335-312YW..... 4	830..... 130	1305GYS..... 102
10H..... 91	164-3..... 125	336-37YW..... 5	840..... 130	1305SDS..... 102
10HL..... 91	164-4..... 125	336-312YW..... 5	841..... 130	1307BE..... 101
12BE..... 102	165-1..... 125	351BL..... 5	842..... 130	1307BK..... 101
12RD..... 102	165-2..... 125	351BZ..... 5	876C..... 130	1307BN..... 101
12WH..... 102	165-3..... 125	351GN..... 5	877..... 130	1307GY..... 101
15..... 102	165-4..... 125	351RD..... 5	885BK..... 107	1358-1..... 111
18BE..... 102	166-1..... 126	351YW..... 5	887BE..... 107	1358-2..... 111
18RD..... 102	167-1..... 125	401SD..... 130	887BK..... 107	1358BE..... 106
18WH..... 102	167-2..... 125	404-3YW..... 5	887GY..... 107	1358BK..... 106
19..... 102	168-1..... 125	404-37YW..... 4	888BK..... 107	1358BN..... 106
23BE..... 102	168-2..... 125	440..... 91	888BN..... 107	1358GN..... 106
23RD..... 102	182BL..... 31	495..... 91	889..... 107	1358GY..... 106
23WH..... 102	182GY..... 31	515..... 52	892..... 107	1425BE..... 101
25-1..... 111	184BL..... 31	516..... 52	902-3RW..... 89	1425BK..... 101
25BE..... 104	184GY..... 31	517..... 52	902BW7..... 90	1425BKS..... 102
25BN..... 104	186BL..... 32	520..... 126	902BW9..... 90	1425BN..... 101
25GY..... 104	186GY..... 32	523BK..... 117	902PW9..... 90	1425BNS..... 102
29..... 32	187YW..... 32	523TN..... 117	902RW7..... 90	1425GY..... 101
32-1..... 111	188YW..... 32	571..... 20	902RW9..... 90	1425GYS..... 102
32BE..... 104	220-12..... 30	573..... 20	902WW7..... 90	1425SDS..... 102
32BN..... 104	221YW..... 29	596..... 19	902WW9..... 90	1427BE..... 101
32GY..... 104	222-3YW..... 29	598..... 19	912BK..... 43	1427BK..... 101
43..... 115	222YW..... 29	600..... 19	916CN..... 90	1427BN..... 101
48..... 114	226-3BL..... 4	601..... 19	922B..... 90	1427GY..... 101
49..... 114	226-3BZ..... 4	605..... 19	924B..... 90	1430BE..... 101
50-1..... 111	226-3YW..... 4	607..... 19	932CG..... 90	1430BK..... 101
51..... 114	226-312BL..... 5	608..... 19	952..... 90	1430BN..... 101
54..... 114	226-312BZ..... 5	630C..... 129	953..... 90	1430GY..... 101
55..... 114	226-312GN..... 5	630W..... 129	989SS..... 129	1432BE..... 100
59..... 114	226-312YW..... 5	631P..... 129	990W..... 129	1432BK..... 100
71NBK..... 106	230-12..... 30	632..... 128	991C..... 129	1432BN..... 100
71NBN..... 106	250C..... 127	633..... 128	992P..... 129	1432GY..... 100
71NGY..... 106	250K..... 127	645-1..... 109	1001GY..... 93	1435BE..... 100
72NBE..... 106	250W..... 127	650..... 107	1001-ICE..... 120	1435BK..... 100
72NGY..... 106	260..... 131	656-1..... 109	1001WH..... 93	1435BN..... 100
75NBE..... 106	266-32YW..... 5	675..... 129	1002GY..... 94	1435GY..... 100
75NGY..... 106	266-36YW..... 5	676..... 128	1002WH..... 94	1525BK-BP..... 116
104..... 124	271..... 32	677..... 128	1181..... 123	1525GY..... 116
105..... 124	275..... 114	678..... 128	1182..... 123	1525GY-BP..... 116
106..... 124	276..... 114	701..... 131	1183..... 123	1525WH..... 116
107..... 124	277..... 114	706..... 131	1184..... 123	1525WH-BP..... 116
119..... 30	330..... 91	711..... 131	1185..... 123	1530GY..... 116
119C..... 30	335-3BL..... 4	712..... 43	1186..... 123	1530WH..... 116
120..... 30	335-3BZ..... 4	715..... 43	1187..... 123	1565BE..... 113
120C..... 30	335-3YW..... 4	716..... 43	1190..... 123	1580BEBN..... 113
125ENG..... 30	335-9YW..... 5	721..... 131	1191..... 123	1585BEBN..... 113
125SP..... 30	335-37BL..... 5	772..... 20	1305BE..... 101	1590BE..... 113
132..... 107	335-37BZ..... 5	780..... 127	1305BK..... 101	1594BN..... 113
153..... 124	335-37YW..... 5	808..... 43	1305BKS..... 102	1702BE..... 105

1702BN	105	2811RD	97	4438BE	106	5835BK	122	8110GY	88
1702GY	105	2818-1	111	4438GY	106	5837BK	122	8110RD	88
1722	28	2818-2	111	4442BK	95	5839BK	122	8110RDGM	88
1725-1	111	2818BE	106	4444BL	94	5840-1	112	8110WH	88
1725-2	111	2818BK	106	4444GN	94	5840BK	122	8110WHGM	88
1730	28	2818BN	106	4444GY	94	5843BK	122	8114GY	88
1750-1	111	2818GN	106	4444GYBP	94	5845BK	122	8114RD	88
1750-2	111	2818GY	106	4444GYINED	94	5849BK	122	8114WH	88
1800	28	2907SD	105	4444RD	94	5850-1	112	8119RD	89
1924	99	2914BK	105	4444WH	94	5850BK	99	8216	89
2000-1	108	2914SD	105	4444YW	94	5850YW	99	8252-H	132
2000BL	93	2927BK	105	4445GY	94	5852BK	122	8252-V	132
2000GY	93	2927BN	105	4445RD	94	5853BK	122	8254	132
2000WH	93	2927SD	105	4445WH	94	5860	121	8255	132
2001GY	94	3155	95	4445YW	94	5865	121	8316BE	103
2001WH	94	3175	95	4456BK	96	5870	121	8316BK	103, 110
2400	28	3200-1	108	4456BL	96	5875	121	8316BN	103
2470	92	3200BL	93	4456GY	96	5880	121	8316GY	103
2472	92	3200GN	93	4456RD	96	5885	121	8319	104, 110
2473	92	3200GY	93	4457GY	96	5906	118	8320	103, 110
2475	92	3200GYBP	93	5000GY	97	5914-1	112	8320-4	103, 110
2510-3	92	3200GYINED	94	5001GY	97	5916-1	112	8321-1	111
2510-11	92	3200RD	93	5323	42	5916BK	123	8321BE	104
2510-22	91	3200WH	93	5325	42	5930	118	8321GY	104
2512-3	92	3200YW	93	5327	42	5936	118	8322-1	110
2512-11	92	3201-1	108	5500GY	94	5948	118	8322-2	110
2512-22	91	3201GY	94	5501GY	94	5960	118	8322BE	103
2514-3	92	3201RD	94	5550BK	96	6012	21	8322BK	103, 110
2514-11	92	3201WH	94	5550BL	96	6112	21	8322BN	103
2514-22	91	3201YW	94	5550GY	96	6451BK	98, 99	8322GY	103
2514-99T	92	3210GY	95	5550RD	96	6452BE	98	8324BE	100
2516-3	92	3231GY	96	5555-1	108	6452BN	98	8324BK	100
2516-22	91	3232BK	96	5556-1	108	6454BE	98	8324BN	100
2518-3	92	3232BL	96	5556GY	97	6454BN	98	8324GY	100
2518-11	92	3232GY	96	5735BE	99	6456BK	98	8325-1	109
2518-22	91	3232RD	96	5735BN	99	6457BK	98	8325-2	109
2518-99T	92	3233GY	96	5750BE	99	6458BK	98, 107	8325-3	109
2550-08	52	3255	96	5750BN	99	6484OY	117	8325-4	109
2550-12	52	3303BW	90	5765BN	99	6485OY	117	8325BE	100
2550-18	52	3303RW	90	5766L	99	6557BK	98	8325BK	100
2550-24	52	3600	28	5800BE	115	6561BK	98	8325BN	100
2551	52	4000-1	108	5800GY	115	6562BE	98	8325-D	100, 109
2556	93	4000GY	97	5801BE	115	6562BN	98	8325GY	100
2557	93	4000RD	97	5801GY	115	6564BE	98	9321	119
2559	89	4001GY	97	5805BE	115	6564BN	98	9326	119
2560	89	4001RD	97	5805BE-PN	115	7315GN	110	9332	118
2562	93	4114-1	111	5805GY	115	7315GY	103, 110	9720BE	119
2563	93	4114-2	111	5805GY-PN	115	7316BL	110	9720BK	119
2800GY	97	4114BE	106	5806BE	115	7316GN	110	9725BE	119
2800RD	97	4114BK	106	5806GY	115	7316YW	110	9725BK	119
2800WH	97	4114BN	106	5810BE	115	7317BL	110	9762CL	121
2801GY	97	4114GN	106	5810BK	115	7325BE	103	9808	120
2801WH	97	4114GY	106	5811BK	116	7325BK	103	9816	120
2803	97	4410GY	95	5812BK	116	7325BN	103	9828	120
2807WH	119	4418-5GY	117	5833BK	122	7325GY	103	9832	120

9864	120	13013	69	14417	60	20014	58	20287	62
9906	120	13014	69	14418	60	20015	58	20288	62
9932	120	13016	69	14419	60	20016	58	20290	62
9964	120	13017	69	14420	60	20017	58	20294	62
10420	69	13018	69	14421	60	20018	58	20298	62
10428	69	13019	69	14422	60	20045	60	20309	62
11032	69	13020	69	14423	60	20046	60	20322	63
10602	69	13021	69	14424	60	20047	60	20323	63
10605	69	13024	69	14438	60	20048	60	20324	63
10608	69	13027	69	15137	63	20049	60	20325	63
10610	69	13032	69	16005	69	20050	60	20326	63
10612	69	13115	69	16008	69	20051	60	20327	63
10613	69	13313	60	16010	69	20052	60	20328	63
10614	69	13314	60	16012	69	20053	60	20329	63
10615	69	13315	60	16013	69	20054	60	20330	63
10616	69	13316	60	16014	69	20055	60	20333	63
10617	69	13317	60	16016	69	20056	60	20348	63
10618	69	13318	60	16017	69	20057	60	20361	64
10619	69	13319	60	16018	69	20124	59	20362	64
10620	69	13320	60	16019	69	20125	59	20363	64
10621	69	13321	60	16020	69	20126	59	20364	64
10624	69	13322	60	16021	69	20127	59	20365	64
10627	69	13324	60	16024	69	20128	59	20366	64
10628	69	13338	60	16027	69	20129	59	20367	64
10632	69	13420	69	16115	69	20130	59	20368	64
11005	69	13428	69	16420	69	20131	59	20369	64
11008	69	13032	69	16428	69	20132	59	20372	64
11010	69	13517	62	16032	69	20133	59	20386	64
11012	69	13518	62	19005	69	20135	59	20387	64
11013	69	13519	62	19008	69	20202	59	20400	64
11014	69	13520	62	19010	69	20203	59	20402	64
11016	69	13521	62	19012	69	20204	59	20403	64
11017	69	13522	62	19013	69	20205	59	20404	64
11018	69	13523	62	19014	69	20206	59	20405	64
11019	69	13524	62	19016	69	20207	59	20406	64
11020	69	13527	62	19017	69	20208	59	20407	64
11021	69	13528	62	19018	69	20209	59	20408	64
11024	69	13537	62	19019	69	20210	59	20411	64
11027	69	13538	62	19020	69	20211	59	20426	64
11032	69	13557	62	19021	69	20213	59	20439	64
11115	69	13917	63	19024	69	20241	58	20441	64
11513	66	13918	63	19027	69	20242	58	20442	64
11514	66	13919	63	19032	69	20243	58	20443	64
11515	66	13920	63	19115	69	20244	58	20450	64
11516	66	13921	63	19420	69	20245	58	20465	64
11517	66	13922	63	19428	69	20246	58	20466	64
11518	66	13924	63	19032	69	20247	58	20478	62
11519	66	13927	63	20006	58	20248	58	20479	62
11520	66	13928	63	20007	58	20249	58	20480	62
11521	66	13957	63	20008	58	20251	58	20481	62
11524	66	14412	60	20009	58	20260	58	20482	62
13005	69	14413	60	20010	58	20283	62	20483	62
13008	69	14414	60	20011	58	20284	62	20485	62
13010	69	14415	60	20012	58	20285	62	20488	62
13012	69	14416	60	20013	58	20286	62	20489	62

20504	62	21512	59	23784	71	24433	71	25741	70
20505	62	21747	59	23785	71	24434	71	25742	70
20517	65	21813	64	23786	71	24435	73	25743	70
20518	65	21919	58	23787	71	24436	73	25744	70
20519	65	22102	60	23840	64	24437	73	25745	70
20520	65	22508	67	24005	65	24438	73	25746	70
20521	65	22584	78	24006	65	24439	73	25747	70
20522	65	23107	77	24007	65	24440	73	25748	70
20524	65	23217	67	24008	65	24441	73	25749	70
20528	65	23330	64	24009	65	24442	73	25750	70
20543	65	23336	64	24010	65	24443	73	25751	70
20908	76	23411	68	24011	65	24444	73	25752	70
20931	67	23412	68	24012	65	24445	73	25753	70
20940	78	23413	68	24014	65	24446	73	25754	70
20941	78	23414	68	24015	65	24446	73	25761	70
20942	78	23421	64	24016	65	24448	73	25762	70
20944	77	23438	57	24017	65	24449	73	25763	70
20945	77	23442	74	24018	65	24456	62	25764	70
20946	77	23443	74	24102	64	24470	51	25765	70
20948	78	23444	73	24151	74	24471	57	25766	70
20949	78	23445	74	24152	74	24472	58	25773	70
20950	78	23446	74	24154	74	24473	58	25774	70
20951	77	23447	74	24155	74	24474	59	25775	70
20952	77	23454	57	24156	74	24475	60	25782	60
20953	77	23455	57	24157	74	24476	60	25783	58
20954	78	23466	57	24158	74	25056	66	25784	58
20955	78	23467	68	24159	74	25228	62	26034	64
20957	77	23468	68	24161	74	25513	59	26040	79
20958	78	23469	68	24162	74	25515	59	26041	79
20959	78	23470	68	24163	74	25516	59	26042	79
20960	77	23471	57	24406	58	25517	59	26044	79
20961	77	23476	57	24407	58	25518	59	26067	67
20967	67	23477	57	24408	58	25520	59	26068	67
20968	67	23478	57	24409	59	25521	59	26649	60
20969	67	23479	57	24410	59	25522	59	26650	60
20972	67	23535	77	24411	59	25524	59	26651	58
20975	67	23553	67	24412	62	25685	66	26710	57
20976	67	23554	67	24413	62	25686	66	26767	77
20978	67	23589	57	24414	62	25687	66	26768	77
20979	67	23623	63	24417	59	25725	70	26769	77
20983	67	23624	64	24418	59	25726	70	26773	77
20984	67	23625	64	24419	59	25727	70	28547	63
20985	67	23628	65	24420	60	25728	70	28548	64
20986	67	23651	74	24421	60	25729	70	29061	57
21310	58	23626	64	24422	60	25730	70	29301	79
21311	58	23671	64	24423	60	25731	70	29302	79
21312	58	23754	71	24424	60	25732	70	29303	79
21313	58	23759	71	24425	60	25733	70	29304	79
21314	58	23760	71	24426	57	25734	70	29305	79
21315	58	23761	71	24427	57	25735	70	29306	79
21316	58	23779	71	24428	57	25736	70	29307	79
21317	58	23780	71	24429	57	25737	70	29404	80
21318	58	23781	71	24430	57	25738	70	29405	80
21320	58	23782	71	24431	57	25739	70	29513	76
21493	58	23783	71	24432	71	25740	70	29514	78

29523	78	42066	72	43215	57	A01502	9	A02811	10
29588	57	42089	72	43216	57	A01503	9	A02812	10
29754	62	42090	72	43217	57	A01511	9	A02813	10
29755	62	42091	72	43218	57	A01512	9	A02814	10
29756	62	42092	72	43219	57	A01513	9	A02901	10
29757	62	42093	72	43220	57	A02001	9	A02902	10
29772	62	42094	72	43221	57	A02002	9	A02903	10
29773	62	42098	72	43222	57	A02003	9	A02904	10
29774	62	42099	72	43224	57	A02004	9	A02911	10
29775	62	42100	72	44817	65	A02011	9	A02912	10
29777	62	42104	72	44818	65	A02012	9	A02913	10
29779	62	42143	72	44819	65	A02013	9	A02914	10
29780	62	42144	72	44820	65	A02014	9	A03001	10
29781	62	42145	72	44821	65	A02101	9	A03002	10
29785	62	42149	72	44822	65	A02102	9	A03003	10
29787	62	42150	72	44824	65	A02103	9	A03011	10
32010	76	42151	72	44827	65	A02104	9	A03012	10
32020	76	42152	72	44828	65	A02111	9	A03013	10
32030	76	42154	72	44829	65	A02112	9	A03151	11
32040	76	42157	72	A00601	8	A02113	9	A03202	12
32050	75	42158	72	A00602	8	A02114	9	A03203	12
32060	75	42159	72	A00603	8	A02401	9	A03212	12
32070	76	42160	72	A00611	8	A02402	9	A03213	12
32080	76	42161	72	A00612	8	A02403	9	A03302	12
32090	76	42162	72	A00613	8	A02404	9	A03303	12
32100	76	42163	72	A00702	8	A02411	9	A03312	12
32110	76	42164	72	A00703	8	A02412	9	A03313	12
32120	76	42165	72	A00711	8	A02413	9	A03501	14
32130	76	42166	72	A00712	8	A02414	9	A03502	14
32140	76	42167	72	A00713	8	A02501	10	A03503	14
41133	72	42168	72	A00901	8	A02502	10	A03511	14
41134	72	42169	72	A00902	8	A02503	10	A03512	14
41991	72	42170	72	A00903	8	A02504	10	A03513	14
41992	72	42171	72	A00911	8	A02511	10	A03612	13
41993	72	42172	72	A00912	8	A02512	10	A03613	13
41994	72	42173	72	A00913	8	A02513	10	A03701	14
41995	72	42174	72	A01101	9	A02514	10	A03702	14
42000	72	42175	72	A01102	9	A02601	10	A03703	14
42001	72	42176	72	A01103	9	A02602	10	A03712	14
42003	72	42177	72	A01111	9	A02603	10	A03713	14
42004	72	42180	72	A01112	9	A02604	10	A05001	11
42006	72	42181	72	A01113	9	A02612	10	A05002	11
42007	72	42184	72	A01201	9	A02613	10	A05003	11
42011	72	42185	72	A01202	9	A02614	10	A05011	11
42012	72	42186	72	A01203	9	A02701	10	A05012	11
42015	72	42187	72	A01211	9	A02702	10	A05013	11
42023	72	42189	72	A01212	9	A02703	10	A05101	11
42027	72	42191	72	A01213	9	A02704	10	A05102	11
42033	72	42193	72	A01301	9	A02711	10	A05103	11
42039	72	42194	72	A01302	9	A02712	10	A05111	11
42043	72	42195	72	A01303	9	A02713	10	A05112	11
42044	72	42199	72	A01311	9	A02801	10	A05113	11
42045	72	43179	72	A01312	9	A02802	10	A09002	13, 26
42046	72	43213	57	A01313	9	A02803	10	A09003	13, 26
42055	72	43214	57	A01501	9	A02804	10	A10001	13, 26

A1000213, 26	A7040062	A41401215	A50332417	A95600312
A1000313, 26	A7061218,19	A41401615	A50333217	A95601112
A1010113, 26	A7062219	A41402015	A50431617	A95602212
A1010213, 26	A7064218	A41402415	A50432017	A95603312
A1010313, 26	A7065218	A41403215	A50432417	A95610112
A1110111	A7066218	A41411215	A50433217	A95610212
A1110211	A7090220	A41411615	A55131617	A95610312
A1110311	A7100220	A41412015	A55132017	A95702415
A1110411	A7101220	A41412415	A55132417	A95712415
A1111111	A7102220	A41413215	A55133217	A95802415
A1111211	A7130220	A41901615	A55231617	A95812415
A1111311	A7161218	A41902015	A55232017	B60101814, 22
A1111411	A8080317	A41902415	A55232417	B60102414, 22
A1120111	A8080523	A41903215	A55233217	B60300022
A1120211	A20201616	A41911615	A55531617	B60800422
A1120311	A20202016	A41912015	A55532017	B61000022
A1120411	A20202416	A41912415	A55532417	B61100022
A1121111	A20203216	A41913215	A55533217	B80500021
A1121211	A20211616	A42701616	A60501217	B80600021
A1121311	A20212016	A42702416	A60501617	B80900021
A1121411	A20212416	A42703216	A60502417	B80950021
A1130111	A20213216	A42711616	A60601217	C123-2YW29
A1130211	A20311616	A42712416	A60601617	C240028
A1130311	A20312016	A42713216	A60602417	C360028
A1130411	A20312416	A42731616	A60603217	C00101835
A1131111	A20313216	A42732416	A90101215	C00102435
A1131211	A20711616	A42733216	A90111215	C00103635
A1131311	A20712016	A42801616	A90201615	C00104835
A1131411	A20712416	A42802416	A90211615	C00106035
A1140114	A20713216	A42803216	A90302015	C00301835
A1140214	A40101215	A42811616	A90312015	C00302435
A1140314	A40101615	A42812416	A90402815	C00303635
A1140414	A40102015	A42813216	A90412815	C00304835
A1141114	A40102415	A43001616	A91101215	C00306035
A1141214	A40103215	A43002016	A91111215	C00401835
A1141314	A40111215	A43002416	A91201615	C00402435
A1141414	A40111615	A43003216	A91211615	C00403635
A1150111	A40112015	A43011616	A91302015	C00404835
A1150211	A40112415	A43012016	A91312015	C00406035
A1150311	A40113215	A43012416	A91402815	C01301835
A1150411	A40192013	A43013216	A91412815	C01302435
A1151111	A40501615	A43031616	A92701015	C01303635
A1151211	A40502015	A43032016	A92711015	C01304835
A1151311	A40502415	A43032416	A92801015	C01306035
A1151411	A40503215	A43033216	A92811015	C01401835
A4230212	A40511615	A43101616	A93701415	C01402435
A4230312	A40512015	A43102016	A93711415	C01403635
A4231312	A40512415	A43102416	A93801415	C01404835
A7030218	A40513215	A43103216	A93811415	C01406035
A7031218	A41001615	A43111616	A94701815	C01501835
A7032218	A41002415	A43112016	A94711815	C01502435
A7034218	A41003215	A43112416	A94801815	C01503635
A7035218	A41011615	A43113216	A94811815	C01504835
A7036218	A41012415	A50331617	A95600112	C01506035
A7060219	A41013215	A50332017	A95600212	C01601835

C01602435	C10401825	C70206041	E50360044	F10201849
C01603635	C10402025	C70207241	E50400044	F10202449
C01604835	C10402425	C70302442	E50402844	F10203049
C01606035	C10602024	C70402442	E50450044	F10203649
C04101836	C10701325	C70600088	E50500045	F10301849
C04102436	C10701825	C70700038	E50600045	F10302449
C04103636	C10702425	C71400026	E50700845	F10303649
C04104836	C10801325	C71400327	E50701245	F10311849
C04106036	C10801825	C71406026	E50711245	F10312449
C04201836	C10802025	C71602427	E51350044	F20101650
C04202436	C10802425	C71602427	E51501245	F50100082
C04203636	C10901824	C71701127	E60100043	F52188050
C04204836	C10902024	C71701627	E60300043	F52248050
C04206036	C11002040	C71701827	E70001685	F53188050
C05101836	C12301825	C71702227	E71001685	F53248050
C05102436	C12302425	C80106041	E72001685	H333SS131
C05103636	C12401825	C80126041	E73001685	H8316BE103
C05104836	C12701825	C90300038	E80001685	H8316BK	..103, 110
C05106036	C12801825	CB-5YW23	E80101685	H8316BN103
C05201836	C12802425	CD10171	E81001685	H8316GY103
C05202436	C30201837	CD10271	E81101685	H8322-1110
C05203636	C30202437	CD10371	E82001685	H8322-2110
C05204836	C30203637	CD11671	E82101685	H8322BE103
C05206036	C30204837	E00100086	E83001685	H8322BK	..103, 110
C05701836	C30206037	E00200086	E83101685	H8322BN103
C05702436	C40101837	E10100086	E84001685	H8322GY103
C05703636	C40102437	E10200086	E84101685	I00101082
C05704836	C40103637	E11700086	E85001685	I00101282
C05706036	C40104837	E12000086	E85101685	I00201082
C05801836	C40106037	E12200088	F00201847	I00201282
C05802436	C40401837	E20200087	F00301847	I00301082
C05803636	C40402437	E20402487	F00302447	I00301282
C05804836	C40403637	E20502587	F00303647	I00400082
C05806036	C40404837	E20601087	F00311847	I00510082
C09001840	C40406037	E20800087	F00312447	I30110881
C09002440	C41201838	E22800087	F00401847	I30112081
C09003640	C41202438	E22400086	F00402447	I30210881
C09004840	C41203638	E22410086	F00403647	I30212081
C09101839	C41204838	E22500086	F00411847	I30300881
C09102439	C41206038	E31700086	F00412447	I30302081
C09103639	C41401837	E32000086	F00601848	I30310881
C09201839	C41402437	E32200088	F00602448	I30312081
C09202439	C41403637	E40220887	F00603648	I30400881
C09203639	C41404837	E40320887	F00611848	I30402081
C09204839	C41406037	E40820887	F00612448	I30410881
C09206039	C42900040	E40910080	F00701848	I30412081
C09501839, 41	C50100038	E50000044	F00702448	I50220881
C09502439, 41	C60100038	E50201844	F00703648	I50222081
C09503639, 41	C62900038	E50202444	F00711848	I60100080
C09504839,41	C63000038	E50202844	F00712448	J005000-0184
C10301325	C70201241	E50203644	F10101849	J005002-0184
C10301825	C70201841	E50300044	F10102449	J005003-0184
C10302025	C70202441	E50301744	F10103649	J20300068
C10302425	C70203641	E50302844	F10111849	J40100084
C10401325	C70204841	E50350044	F10112449	J501001126

J502100	126	M104060	51	N006019	73	RT22	130	SYSK-1	23
J503001	126	M105060	51	N006021	73	RT23	130	SYSK-2	23
J506000	126	M106060	51	N007017	73	S222-1RD	29	T1600BE	105
J507017	127	M109054	51	N007019	73	SB-5YW	23	T1600BN	105
K001000	83	M109060	51	N007021	73	SW2YW	3	T1600GY	105
K003000	83	M117060	51	N009017	74	SW7BL	3	T1700BE	105
L401000	83	M119060	51	N009019	74	SW7BZ	3	T1700BN	105
L402000	83	M202000	50	N009021	74	SW7YW	3	T1700GY	105
L403000	83	MF-5BK	23	N012008	74	SW9YW	3	T1700WH	105, 111
L404000	83	MFH-28	27	NI100	124	SW12BL	3	T7318BN/BE	103
L407124	83	MFT-5BK	23	NI101MF	124	SW12BZ	3	T7318GY/GY	103
L407224	83	N002017	73	P129-1	124	SW12GN	3	V444SS	131
L407324	83	N002019	73	P135-1	124	SW12YW	3	W222BK	30
LD501	131	N002021	73	P222	124	SYS-5	23	WJ509001	127
M101060	51	N006017	73	RRVP-1	126	SYSH-5	27	WJ510000	127

EARTHTONE™

Sustainable Solutions



EarthTone™ ~ products that support sustainability



For product information or a distributor near you:
Inside the US 800.325.1051 • Canada 800.387.5100 • Outside the US & Canada +1.314.656.4301

© 2012 Continental Commercial Products, 305 Rock Industrial Park Drive, Bridgeton, MO 63044
fax: 800.327.5492 • www.continentalcommercialproducts.com

Printed on
Recycled Paper



10215094