

PARTS LIST for D068 Trolley		
Item	Description	QTY
A	C Frame	2
B	L Frame	2
C	T Frame	2
D	Top Support Plate	1
E	Bolt & Washer	16
F	Castors	4

ASSEMBLY INSTRUCTIONS - refer to diagram

- Assemble base of Trolley first
 - Insert frames (A) into frames (B) and fix each side with 2 bolts (E) (8 bolts total)
 - NOTE: Base frame is expandable. If using the trolley in the medium or high size, fully extend the frame (A) to the outer bolt holes in frame (B) to ensure the base of the trolley will be stable.
- Insert frame (C) into frame (B). Fix frame (C) in place using 2 bolts on each side. Frame (C) is height adjustable, there are 4 height settings, choose the correct height for the length of plans that will be stored in the assembled trolley.
- Fix the Top Support Plate (D) to the top of the frame (C) with 4 bolts
- Screw 4 Castors (F) into the bottom of the assembled trolley
- Adding Hanging Clamps / Binders to Trolley
 - Trolley is supplied without Clamps, these need to be purchase separately
 - Trolley total capacity: 15 Clamps, max Clamp size is 30", B1 Size
 - Hang Clamps on trolley as shown in illustration

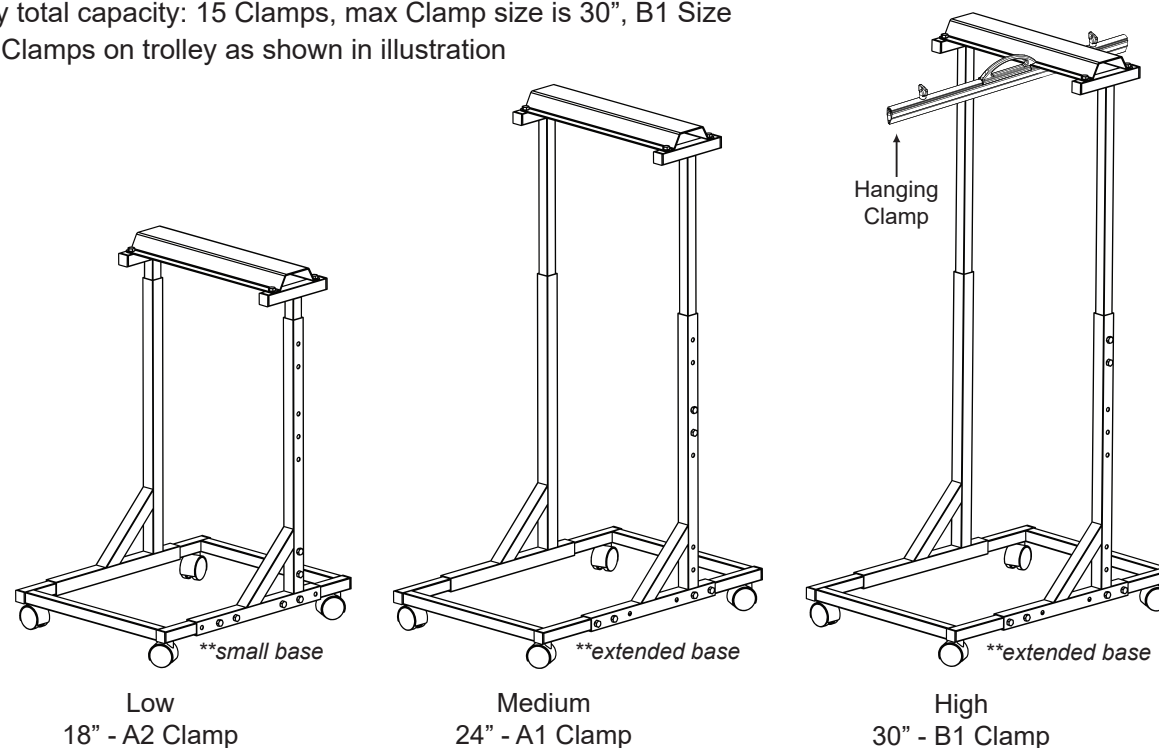
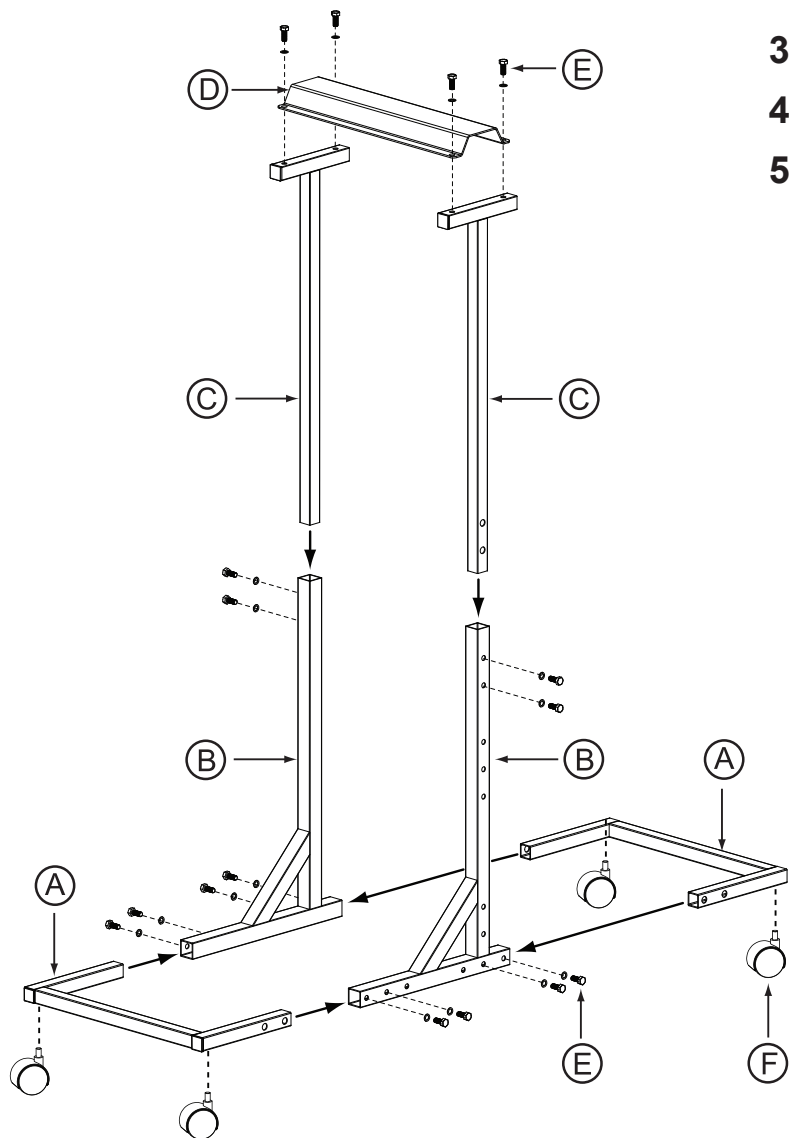

Assembled Trolley Height Settings
 Important - increase size of base for medium and high trolley sizes