



# GLOBAL<sup>TM</sup> INDUSTRIAL

User's manual

Customer Service  
US: 1-800-645-2986

## Operating Instructions

### Hand Operated Lift Truck

Model 989051, 989052, 989053



## **Content**

- 1. Description**
- 2. Specification**
- 3. General Safety Information**
- 4. Safety Principles**
- 5. Pre-operation Inspection**
- 6. Assembly Instructions**
- 7. Function Tests**
- 8. Workplace Inspection**
- 9. Operating Instructions**
- 10. Load Capacity Charts**

## Description

Hand Operated Lift Truck is used to lift material to and from shelves, move office equipment and install ceiling and wall appliances on level surfaces, including workshops, warehouses, stockrooms, receiving departments. Perfect when aisles and congested areas prevent the use of larger equipment. Rolls through standard doorways in the upright position without having to tilt back the truck. Constructed of durable steel and lightweight aluminum frame. Forks can be inverted to provide two different lift heights. Operated by a hand-crank winch. Lightweight and portable, as upper handle rollers allow the truck to be loaded onto its back for easy van or pickup transporting.



Each hand operated lift truck conforms to the generalized specifications disclosed in this manual and fulfills our demanding standards for quality, safety and durability. This manual adopts relevant provisions of the following standards:

1. ANSI/ITSDF standard B56.10-2006, "Safety Standard for Manually Propelled High Lift Industrial Trucks".
2. EN ISO standard EN ISO 3691-5:2009 Industrial trucks — Safety requirements and verification —Part 5: Pedestrian-propelled trucks

## Important

Employees and any other persons, who might foreseeable use, install, or perform maintenance on the Hand operated Lift Truck, must read and understand every instruction before using it.

Model	Load Cap.		Lifting Height				Overall Dim.						Load Center	
	kg	lb	Forks Up		Forks Down		L		W		H			
			m	in	m	in	cm	in	cm	in	cm	in	cm	in
989053	181	400	3.0	120	2.5	98	87.6	34-1/2	61	24	170	67	25.4	10
989052	227	500	1.8	70	1.2	47	87.6	34-1/2	61	24	170	67	25.4	10
989051	181	400	3.0	120	2.5	98	110	43	73.6	29	170	67	25.4	10

## General Safety Information

**Each person who might participate in the assembly, use, inspection or maintenance of the product must read the entire manual and fully understand the directions BEFORE assembling, using, inspecting or maintaining the Hand Operated Lift Truck.**

**CAUTION: Carefully read all manuals included with this product before putting into service. Never exceed the maximum capacity of the lift. Load must be evenly distributed and load center limits must not be exceeded.**

**CAUTION: Use caution and be aware of pinch and crush points. Never place hands, feet, or objects under forks or platform**

**CAUTION: Do not use on inclines or uneven surfaces.**

**CAUTION: Never leave the load unattended in a raised position.**

**CAUTION: Transporting or lifting persons is not permitted.**

## Warning

Failure to obey the instructions and safety rules in this manual may result in DEATH or SERIOUS INJURY.

The manufacturer is not liable for any injury or property damage that occurs as a consequence of failing to apply the safe operation and maintenance procedures explained in this manual or that appear on labels affixed to the product.

## Safety Principles

### Fall Hazards

- Do not use as a personnel lifting platform or step.
- Do not stand or sit on the forks, load platform or boom.
- Do not climb on the machine



### Tip-over Hazards

- Do not exceed the rated load capacity. See Load Capacity Charts section.
- Do not raise the load unless the leg lock pins have been properly inserted into the legs.
- Do not raise the load unless the correct length legs are properly installed.
- Do not raise the load unless the machine is on a firm, level surface.



- Do not move the machine with a raised load, except for minor positioning.
- Do not tilt the machine back with a raised load.
- Do not use blocks to level the machine.
- Do not operate the machine in strong or gusty winds. Increasing the load surface area will decrease machine stability in windy conditions.
- Do not place ladders or scaffolding against any part of the machine.
- Do not operate the machine unless the wheel/leg/caster configuration is properly installed.
- Prior to use, check the work area for drop-offs, holes, bumps, debris, unstable or slippery surfaces or other possible hazardous conditions.
- Avoid debris and uneven surfaces while rolling a machine with the legs not installed.
- Do not replace machine parts critical to stability or structure with items of different weight or specification.
- Do not cause a horizontal force or side load to the machine by raising or lowering a fixed or overhanging load.
- Do not use the machine on a moving or mobile surface or vehicle.

### Collision Hazards

- Do not raise if the load is not properly centered on the forks or load platform.
- Check the work area for overhead obstructions or other possible hazards.
- Do not stand under or allow personnel under the machine when the load is raised.
- Do not lower the load unless the area below is clear of personnel and obstructions.
- Use common sense and planning when transporting the machine on an incline, slope or stairs.



**Electrocution Hazards**

This machine is not electrically insulated and will not provide protection from contact with or proximity to electrical current.

Maintain safe distances away from electrical power lines and apparatus in accordance with applicable governmental regulations and the following chart.

Voltage	Minimum Safe Approach Distance	
	Feet	Meters
Phase to Phase		
0 to 300V	Avoid	Contact
300V to 50KV	10	3.1
50KV to 200KV	15	4.6
200KV to 350KV	20	6.1
350KV to 500KV	25	7.6
500KV to 750KV	35	10.7
750KV to 1000KV	45	13.7

Allow for mast movement and electrical line sway or sag, and be aware of strong or gusty winds.

Keep away from the machine if it contacts energized power lines. Personnel must not touch or operate the machine until power lines are shut off.

Do not use the machine as a ground for welding.

**Bodily Injury Hazards**

Do not grasp the cable.

Keep hands and fingers away from the pulleys, carriage and other potential pinch points.

**Improper Use Hazard**

Never leave a machine unattended with a load.

Unauthorized personnel may attempt to operate the machine without proper instruction, creating an unsafe condition.

**Damaged Machine Hazards**

Do not use a damaged or malfunctioning machine.

Do not use a machine with a worm, frayed, kinked or damaged cable.

Do not use a machine with less than 4 wraps of cable on the winch drum when the carriage is fully lowered.

Conduct a thorough pre-operation inspection prior to each use.

Be sure that all decals are legible and in place.

Maintain proper lubrication on the winch.

Do not allow oil or grease on braking surfaces.



**Crushing Hazard**

Maintain a firm grasp on the winch handle until the brake is locked. The brake is locked when the load will not cause the winch handle to turn.

### Lifting Hazard

Use proper lifting techniques to load or tip the machine, or move the machine on stairs.

Do not move the machine on stairs when the machine is equipped with the 4 point caster option.

## Pre-operation Inspection

### Do Not Operate Unless:

You learn and practice the principles of safe machine operation contained in this operator's manual.

1. Avoid hazardous situations.
2. Always perform a pre-operation inspection.

Know and understand the pre-operation inspection before going on to the next section.

3. Always perform function tests prior to use
4. Inspect the workplace.
5. Only use the machine as it was intended

### Fundamentals

The Pre-operation Inspection is a visual inspection performed by the operator prior to each work shift.

This inspection is designed to discover if anything is apparently wrong with a machine before the operator test it.

Inspect the machine for modifications, damage or loose or missing parts.

A damaged or modified machine must never be used. If damage or any variation from factory delivered condition is discovered, the machine must be tagged and removed from service.

Repairs to the machine may only be made by a qualified service technician, according to the manufacturer's specifications. After repairs are completed, the operator must perform a pre-operation inspection again before testing the machine functions.

Be sure that the operator's manual is complete, legible and available for reference.

Be sure that all decals are legible and in place.

Check the following components or areas for damage, modifications and improperly installed or missing parts:

- Winch and related components
- Base components
- Legs
- Roller wheels
- Inner and outer frames
- Glide buttons
- Carriage hold-down assembly
- Cable anchor
- Cable and pulleys
- Wheels and casters
- Forks

- Load platform (if equipped)
- Nuts, bolts and other fasteners
- Cable (kinks, frays, abrasions)
- Brake system (if equipped)

Check the entire machine for:

- Dents or damage
- Corrosion or oxidation
- Cracks in welds or structural components

Be sure that all structural and other critical components are present and all associated fasteners and pins are in place and properly tightened.

Be sure there is a minimum of 4 wraps of cable around the winch drum when the carriage is fully lowered.

## Assembly Instructions

For 989053,989052,989051

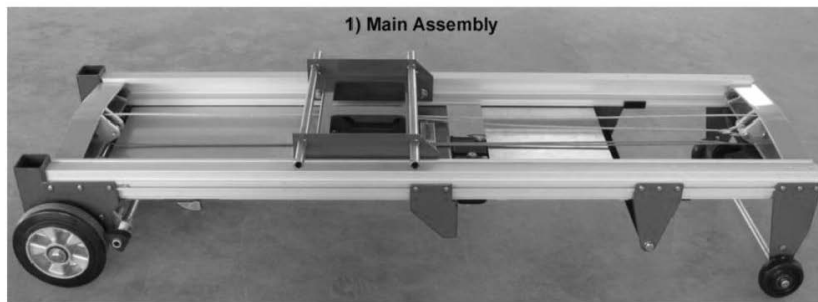
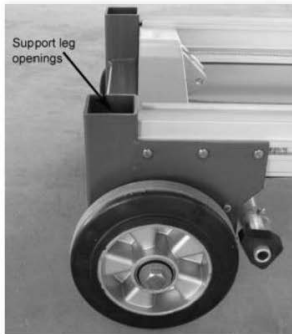

**Step 1: Connect the support legs to the main assembly by following below instructions**

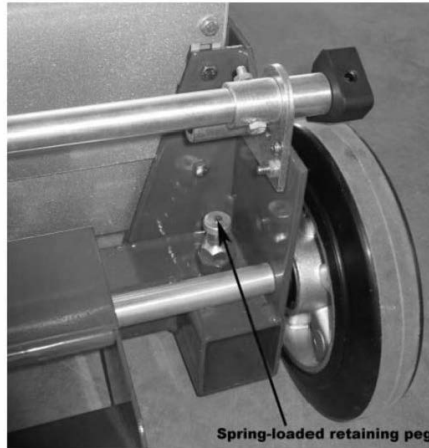

- (1) Insert a support leg into each of the openings in the main assembly.
- (2) One at a time, pull the retaining pegs to allow the legs to slide further into the openings.
- (3) Slowly release the pegs. You may have to wiggle the leg to get the peg to drop.
- (4) Pull upwards on each of the support legs to verify that they are held in place by the pegs. The legs should not be able to slide out of the opening.
- (5) If a leg comes out of the opening, the corresponding peg did not engage properly.

**Step 2: Lift the assembly to the upright position (photo A), lock the brakes (photo B) and fasten the winch handle to the winch body.**

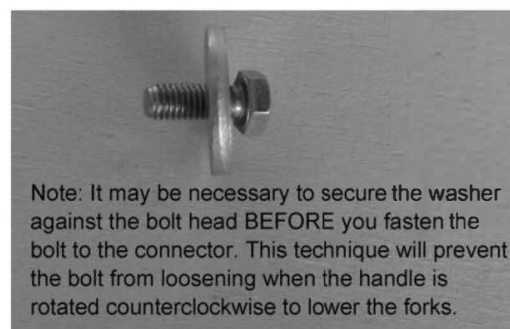
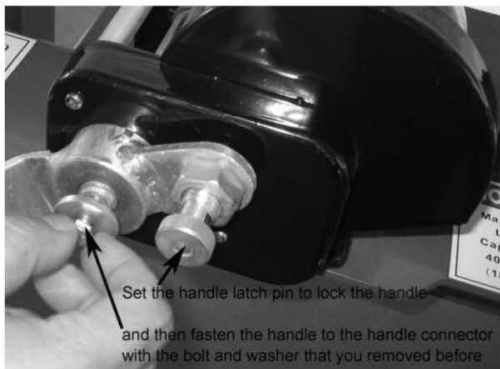
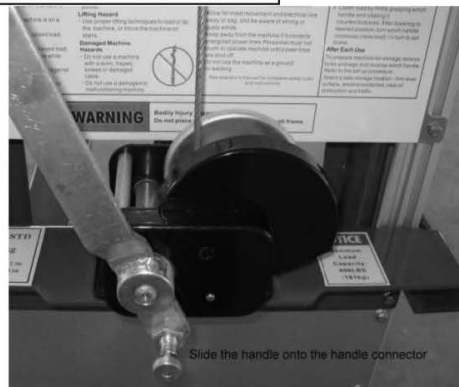
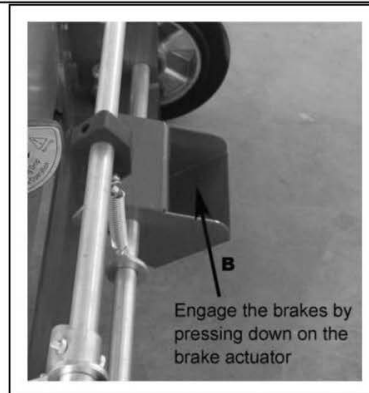
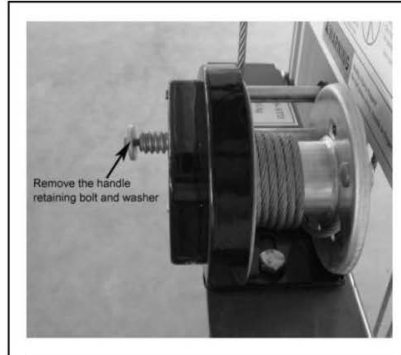
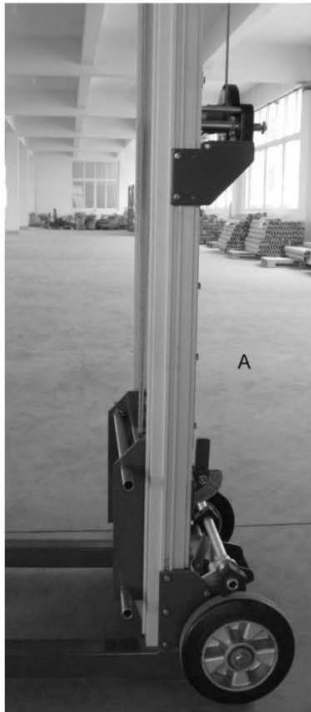

**Step 3: Attach the forks to the carriage**

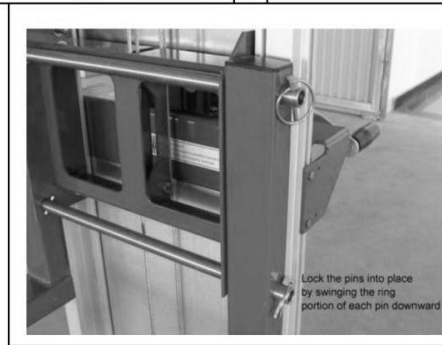
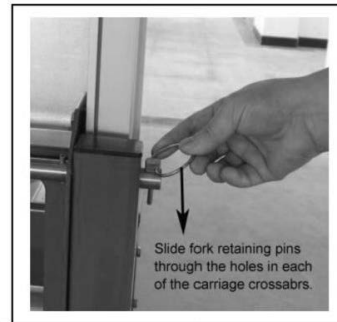
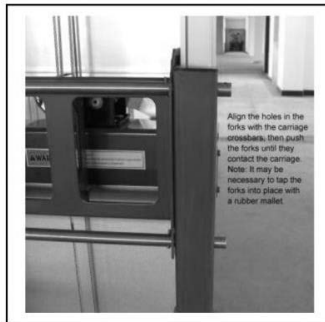
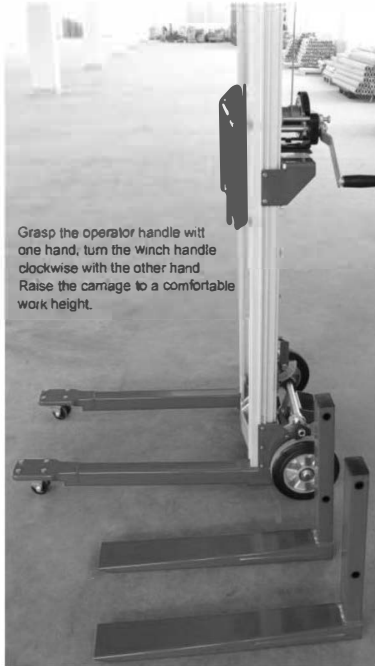

**Step 4: Turn the winch handle counterclockwise to lower the forks. Lower the forks until they are a few inches above the support legs, and then push the lifter to the desired location.**

**Using the Slip-On Platform 989054 (For all models):**



3. Pull up on the foot pedal to release the brake.
4. Push the machine.

Result: The machine should move.

### **Test the Winch Operation**

Note: The model 989052 does not have an inner frame.

1. Rotate the winch handle clockwise to raise the carriage.

Result: The carriage should raise to the top of the inner frame and then the inner frame should raise. The carriage and inner frame should move smoothly, free of hesitation and blinding.

2. Rotate the winch handle counterclockwise to lower the carriage.

Result: The inner frame and the carriage should lower into the outer frame. The carriage and inner frame should move smoothly, free of hesitation and binding.

## **Work place Inspection**

### **Do Not Operate Unless:**

You learn and practice the principles of safe machine operation contained in this operator's manual.

1. Avoid hazardous situations.
2. Always perform a pre-operation inspection.
3. Always perform function tests prior to use.
4. Inspect the workplace.

Know and understand the workplace inspection before going on to the next section.

5. Only use the machine as it was intended

## **Fundamentals**

The Workplace Inspection helps the operator determine if the workplace is suitable for safe machine operation. It should be performed by the operator prior to moving the machine to the workplace.

It is the operator's responsibility to read and remember the workplace hazards, the watch for and avoid them while moving, setting up and operating the machine.

Be aware of and avoid the following hazardous situations:

- Drop-offs or holes
- Bumps and floor obstructions
- Debris
- Overhead obstructions and high voltage conductors
- Hazardous locations
- Inadequate surface support to withstand all load forces imposed by the machine
- Wind and weather conditions
- All other possible unsafe conditions

## Operating Instructions

### Do Not Operate Unless:

You learn and practice the principles of safe machine operation contained in this operator's manual.

1. Avoid hazardous situations.
2. Always perform a pre-operation inspection.
3. Always perform function tests prior to use.
4. Inspect the workplace.
5. Only use the machine as it was intended.

### Fundamentals

Using the machine for any purpose other than lifting material is unsafe.

If more than one operator is expected to use a machine at different times in the same work shift, each operator is expected to follow all safety rules and instructions in the operator's manual. That means. That means every new operator should perform a pre-operation inspection, function tests and a workplace inspection before using the machine.

### Setup

Select an area that is firm, level and free of obstructions.

Follow the Setup procedures in the Function Tests section.

### Raising and Lowering load-Manual Winch

1. Center the load on the forks or load platform
2. Raise the load by firmly grasping the winch handle and rotating it clockwise. Do not allow the cable to wind unevenly onto the winch drum.
3. Lower the load by firmly grasping the winch handle and rotating it counterclockwise. After lowering to the desired position, turn the winch handle clockwise (raise the load)1/4 turn to set the brake.

### Moving Machine with a Load

It is best to move the machine on the work site with no load. Moving a raised load should be restricted to positioning for loading and unloading. If it is necessary to move the machine with a raised load, understand and obey the following safety rules:

- Make sure the area is level and clear of obstructions
- Make sure the load is centered on the forks or load platform
- Avoid sudden starts and stops
- Travel with the load in the lowest possible position
- Keep personnel away from the machine and load
- Do not tilt the machine back with a raised load

### Moving Machine on Stairs

It is best to move the machine on stairs using the optional stair glides. Moving the machine on stairs without the use for stair glides is not recommended, If it necessary to move the machine on stair,

understand and obey the following safety rules:

- Do not move the machine on stairs when the machine is equipped with the 4 point caster option.
- Fully lower the load.
- Ease the machine over each stair. Maintain a firm grasp on the handle.
- Do not allow the machine to become unbalanced .
- Continue carefully up or down the stairs
- Use the appropriate number of people and proper lifting techniques with heavier loads.

### **After Each Use**

To prepare the machine for storage, remove the forks and legs and reverse the winch handle. Refer to the Setup procedure.

Select a safe storage location-firm level surface, weather protected, clear of obstruction and traffic.

### **Transport Instructions**

#### ***Observe and Obey:***

1. Be sure the vehicle capacity and loading surfaces are sufficient to support the machine weight. See Specifications section.
2. Do not load machine onto a vehicle unless it is parked on a level surface.
3. Remove the load from the forks, boom or load platform before loading for transport.
4. The transport vehicle must be secured to prevent rolling while the machine is being loaded.
5. The machine must be securely fastened to the transport vehicle.

### ***Lifting Instructions***

The number of people required to load and unload a machine is dependent on a number of factors, including but not limited to:

- The physical condition, strength and disabilities or prior injuries of the people involved
- The vertical and horizontal distances the machine has to be moved
- The number of times the machines will be loaded or unloaded
- The stance, posture and grip used by the people involved
- The lifting techniques used
- The site conditions and weather in which the activity is being performed (i.e., slippery, icy, raining)

The appropriate number of people and proper lifting techniques must be used to prevent physical injury.

### ***Loading for Transport***

1. Fully lower the carriage.
2. Rotate the carriage hold-down bar over the carriage. Be sure the lock pin snaps into place.
3. Remove the winch handle, reverse the handle and install it. The handle grip should face the carriage.

## Load Capacity Charts

### Observe and Obey:

1. Failure to properly position the load may result in death or serious injury.
2. Verify that the load you wish to raise does not exceed the maximum load for your load center. See the load capacity charts on the next page.

**WARNING:** Tip-over hazard: Raising a load that exceeds the machine capacity may result in death or serious injury. 3. A load center is defined as the balancing point (center of gravity) of a load and must be positioned within the load center zone.

**WARNING:** Tip-over hazard: Failure to position the load center within the load center zone may result in may death or serious injury.

### Forks

#### Load Positioning Instructions

1. Determine the weight of the load and the location of its load center.
2. Measure to the load center from the side of the load that will be closest to the carriage.
3. Refer to the chart on the next page to determine if the machine is capable of lifting the weight at the location on the fork.
4. Place the load so that it rests on the forks, as close to the carriage as possible.
5. Position the load so that the load center is within the load center zone.

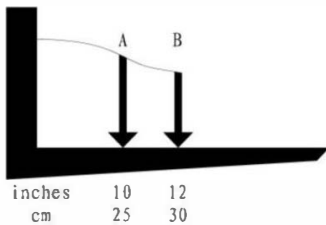

Model	25.4cm	11in	30.5cm	12in
989053	181kgs	400lbs	159kgs	350lbs
989052	227kgs	500lbs	204kgs	450lbs
989051	181kgs	400lbs	159kgs	350lbs

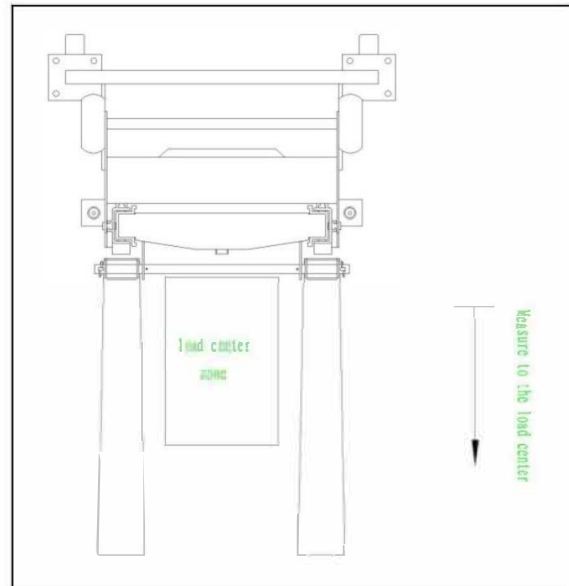

#### Maximum Load Centers (measure from front of carriage)

Forks:	30.5cm	12in
Load Platform	30.5cm	12in