



FS-1120D FS-1320D

OPERATION GUIDE



Please read this Operation Guide before using this machine. Keep it close to the machine for easy reference.

This Operation Guide is for models FS-1120D and FS-1320D.



Note This Operation Guide contains information that corresponds to using both the inch and metric versions of these machines.

The inch versions of these machines are shown in the screens in this guide. If you are using the metric version, use the messages provided for the inch version as reference only. In the body text, only the inch messages are given if these versions differ only in capitalization. When there is even a slight difference in the message, we have listed the information for the inch version followed, in brackets, by the corresponding information for the metric version.

This Operation Guide is intended to help you operate the machine correctly, perform routine maintenance and take a simple troubleshooting action as necessary, so that you can always use the machine in good condition.

Please read this Operation Guide before you start using the machine, and keep it close to the machine for easy reference.

We recommend the use of our own brand supplies. We will not be liable for any damage caused by the use of third party supplies in this machine.

A label shown in the illustration assures that the supplies are our own brand.

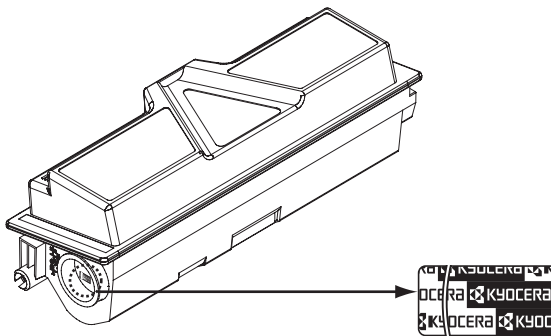

Contents

1	Machine Parts	1-1
	Components at the Front of the Printer	1-2
	Components at the Rear of the Printer	1-3
	Operation Panel	1-4
	Indicators	1-5
	Keys	1-6
2	Loading Paper	2-1
	General Guidelines	2-2
	Selecting the Right Paper	2-4
	Paper Type	2-10
	Preparing the Paper	2-11
	Loading Paper into Cassette	2-11
	Loading Paper into MP (Multi-Purpose)Tray	2-14
3	Connecting and Printing	3-1
	Connections	3-2
	Installing the Printer Driver	3-3
	Printing	3-9
	Status Monitor	3-10
	Configuration Tool	3-14
	Uninstalling Software (Windows PC)	3-18
4	Maintenance	4-1
	General Information	4-2
	Toner Container Replacement	4-2
	Maintenance Kit Replacement	4-5
	Cleaning the Printer	4-6
	Prolonged Non-Use and Moving of the Printer	4-9
5	Troubleshooting	5-1
	General Guidelines	5-2
	Print Quality Problems	5-3
	Understanding Indicators	5-5
	Cleaning Paper Jams	5-11
6	Option	6-1
	General Information	6-2
	Expansion Memory Modules	6-3
	Removing a Memory Module	6-5
	Verifying the expanded memory	6-5
	Paper Feeder (PF-100)	6-6
	Network Interface Card (IB-23)	6-7
	CompactFlash (CF) Card	6-8
7	Appendix	7-1
	Specifications	7-2
	Environmental Standard Requirements	7-4
	Index	Index-1

Legal and Safety Information

Please read this information before using your machine. This chapter provides information on the following topics:

Legal Information	iv
License Agreements	v
Safety Information	ix
Symbols	xiii
Installation Precautions	xiv
Precautions for Use	xvi
About the Operation Guide	xviii
Conventions in This Guide	xix

Legal Information



CAUTION NO LIABILITY IS ASSUMED FOR ANY DAMAGE CAUSED BY IMPROPER INSTALLATION.

Notice on Software

SOFTWARE USED WITH THIS PRINTER MUST SUPPORT THE PRINTER'S EMULATION MODE. The printer is factory-set to emulate the PCL. The emulation mode can be changed.

Notice

The information in this guide is subject to change without notification. Additional pages may be inserted in future editions.

The user is asked to excuse any technical inaccuracies or typographical errors in the present edition. No responsibility is assumed if accidents occur while the user is following the instructions in this guide. No responsibility is assumed for defects in the printer's firmware (contents of its read-only memory).

This guide, and any copyrightable subject matter sold or provided with or in connection with the sale of the page printer, are protected by copyright. All rights are reserved. Copying or other reproduction of all or part of this guide, or any copyrightable subject matter without the prior written consent of Kyocera Mita Corporation is prohibited. Any copies made of all or part of this guide, or any copyrightable subject must contain the same copyright notice as the material from which the copying is done.

Regarding Tradenames

PRESCRIBE is a registered trademark of Kyocera Corporation. KPDL is trademark of Kyocera Corporation. Hewlett-Packard, PCL, and P.J.L are registered trademarks of Hewlett-Packard Company. Adobe, Acrobat, Flash, and PostScript are registered trademarks of Adobe Systems Incorporated. Macintosh and Bonjour are registered trademarks of Apple Computer, Inc. Microsoft and Windows are registered trademarks of Microsoft Corporation. Microsoft Windows Server is a trademark of Microsoft Corporation. PowerPC is a trademark of International Business Machines Corporation. CompactFlash is a trademark of SanDisk Corporation. ENERGY STAR is a U.S. registered mark. All other brand and product names are registered trademarks or trademarks of their respective companies.

This product was developed using the Tornado™ Real Time Operating System and Tools from Wind River Systems.

This product contains UFST™ and MicroTypeR from Monotype Imaging Inc.

License Agreements

IBM Program License Agreement

THE DEVICE YOU HAVE PURCHASED CONTAINS ONE OR MORE SOFTWARE PROGRAMS ("PROGRAMS") WHICH BELONG TO INTERNATIONAL BUSINESS MACHINES CORPORATION ("IBM"). THIS DOCUMENT DEFINES THE TERMS AND CONDITIONS UNDER WHICH THE SOFTWARE IS BEING LICENSED TO YOU BY IBM. IF YOU DO NOT AGREE WITH THE TERMS AND CONDITIONS OF THIS LICENSE, THEN WITHIN 14 DAYS AFTER YOUR ACQUISITION OF THE DEVICE YOU MAY RETURN THE DEVICE FOR A FULL REFUND. IF YOU DO NOT SO RETURN THE DEVICE WITHIN THE 14 DAYS, THEN YOU WILL BE ASSUMED TO HAVE AGREED TO THESE TERMS AND CONDITIONS.

The Programs are licensed not sold. IBM, or the applicable IBM country organization, grants you a license for the Programs only in the country where you acquired the Programs. You obtain no rights other than those granted you under this license.

The term "Programs" means the original and all whole or partial copies of it, including modified copies or portions merged into other programs. IBM retains title to the Programs. IBM owns, or has licensed from the owner, copyrights in the Programs.

1. License

Under this license, you may use the Programs only with the device on which they are installed and transfer possession of the Programs and the device to another party.

If you transfer the Programs, you must transfer a copy of this license and any other documentation to the other party. Your license is then terminated. The other party agrees to these terms and conditions by its first use of the Program.

You may not:

1. use, copy, modify, merge, or transfer copies of the Program except as provided in this license;
2. reverse assemble or reverse compile the Program; or
3. sublicense, rent, lease, or assign the Program.

2. Limited Warranty

The Programs are provided "AS IS."

THERE ARE NO OTHER WARRANTIES COVERING THE PROGRAMS (OR CONDITIONS), EXPRESS OR IMPLIED, INCLUDING, BUT NOT LIMITED TO, THE IMPLIED WARRANTIES OF MERCHANTABILITY AND FITNESS FOR A PARTICULAR PURPOSE.

Some jurisdictions do not allow the exclusion of implied warranties, so the above exclusion may not apply to you.

3. Limitation of Remedies

IBM's entire liability under this license is the following;

For any claim (including fundamental breach), in any form, related in any way to this license, IBM's liability will be for actual damages only and will be limited to the greater of:

-
1. the equivalent of U.S. \$25,000 in your local currency; or
 2. IBM's then generally available license fee for the Program

This limitation will not apply to claims for bodily injury or damages to real or tangible personal property for which IBM is legally liable.

IBM will not be liable for any lost profits, lost savings, or any incidental damages or other economic consequential damages, even if IBM, or its authorized supplier, has been advised of the possibility of such damages. IBM will not be liable for any damages claimed by you based on any third party claim. This limitation of remedies also applies to any developer of Programs supplied to IBM. IBM's and the developer's limitations of remedies are not cumulative. Such developer is an intended beneficiary of this Section. Some jurisdictions do not allow these limitations or exclusions, so they may not apply to you.

4. General

You may terminate your license at any time. IBM may terminate your license if you fail to comply with the terms and conditions of this license. In either event, you must destroy all your copies of the Program. You are responsible for payment of any taxes, including personal property taxes, resulting from this license. Neither party may bring an action, regardless of form, more than two years after the cause of action arose. If you acquired the Program in the United States, this license is governed by the laws of the State of New York. If you acquired the Program in Canada, this license is governed by the laws of the Province of Ontario. Otherwise, this license is governed by the laws of the country in which you acquired the Program.

Typeface Trademark Acknowledgement

All resident fonts in this printer are licensed from Monotype Imaging Inc. Helvetica, Palatino and Times are registered trademarks of Linotype-Hell AG. ITC Avant Garde Gothic, ITC Bookman, ITC ZapfChancery and ITC Zapf Dingbats are registered trademarks of International Typeface Corporation.

Monotype Imaging License Agreement

1. "Software" shall mean the digitally encoded, machine readable, scalable outline data as encoded in a special format as well as the UFST Software.
2. You agree to accept a non-exclusive license to use the Software to reproduce and display weights, styles and versions of letters, numerals, characters and symbols ("Typefaces") solely for your own customary business or personal purposes at the address stated on the registration card you return to Monotype Imaging. Under the terms of this License Agreement, you have the right to use the Fonts on up to three printers. If you need to have access to the fonts on more than three printers, you need to acquire a multi-user license agreement which can be obtained from Monotype Imaging. Monotype Imaging retains all rights, title and interest to the Software and Typefaces and no rights are granted to you other than a License to use the Software on the terms expressly set forth in this Agreement.

-
3. To protect proprietary rights of Monotype Imaging, you agree to maintain the Software and other proprietary information concerning the Typefaces in strict confidence and to establish reasonable procedures regulating access to and use of the Software and Typefaces.
 4. You agree not to duplicate or copy the Software or Typefaces, except that you may make one backup copy. You agree that any such copy shall contain the same proprietary notices as those appearing on the original.
 5. This License shall continue until the last use of the Software and Typefaces, unless sooner terminated. This License may be terminated by Monotype Imaging if you fail to comply with the terms of this License and such failure is not remedied within thirty (30) days after notice from Monotype Imaging. When this License expires or is terminated, you shall either return to Monotype Imaging or destroy all copies of the Software and Typefaces and documentation as requested.
 6. You agree that you will not modify, alter, disassemble, decrypt, reverse engineer or decompile the Software.
 7. Monotype Imaging warrants that for ninety (90) days after delivery, the Software will perform in accordance with Monotype Imaging-published specifications, and the diskette will be free from defects in material and workmanship. Monotype Imaging does not warrant that the Software is free from all bugs, errors and omissions.
 8. THE PARTIES AGREE THAT ALL OTHER WARRANTIES, EXPRESSED OR IMPLIED, INCLUDING WARRANTIES OF FITNESS FOR A PARTICULAR PURPOSE AND MERCHANTABILITY, ARE EXCLUDED.
 9. Your exclusive remedy and the sole liability of Monotype Imaging in connection with the Software and Typefaces is repair or replacement of defective parts, upon their return to Monotype Imaging.
 10. IN NO EVENT WILL MONOTYPE IMAGING BE LIABLE FOR LOST PROFITS, LOST DATA, OR ANY OTHER INCIDENTAL OR CONSEQUENTIAL DAMAGES, OR ANY DAMAGES CAUSED BY ABUSE OR MISAPPLICATION OF THE SOFTWARE AND TYPEFACES.
 11. Massachusetts U.S.A. law governs this Agreement.
 12. You shall not sublicense, sell, lease, or otherwise transfer the Software and/or Typefaces without the prior written consent of Monotype Imaging.
 13. Use, duplication or disclosure by the Government is subject to restrictions as set forth in the Rights in Technical Data and Computer Software clause at FAR 252-227-7013, subdivision (b)(3)(ii) or subparagraph (c)(1)(ii), as appropriate. Further use, duplication or disclosure is subject to restrictions applicable to restricted rights software as set forth in FAR 52.227-19 (c)(2).
 14. YOU ACKNOWLEDGE THAT YOU HAVE READ THIS AGREEMENT, UNDERSTAND IT, AND AGREE TO BE BOUND BY ITS TERMS AND CONDITIONS. NEITHER PARTY SHALL BE BOUND BY ANY STATEMENT OR REPRESENTATION NOT CONTAINED IN THIS AGREEMENT. NO CHANGE IN THIS AGREEMENT IS EFFECTIVE UNLESS WRITTEN AND SIGNED BY PROPERLY AUTHORIZED REPRESENTATIVES OF EACH PARTY. BY OPENING THIS DISKETTE PACKAGE, YOU AGREE TO ACCEPT THE TERMS AND CONDITIONS OF THIS AGREEMENT.

Compliance and Conformity

This equipment has been tested and found to comply with the limits for a Class B digital device, pursuant to Part 15 of the FCC Rules. These limits are designed to provide reasonable protection against harmful interference in a residential installation. This equipment generates, uses and can radiate radio frequency energy and, if not installed and used in accordance with the instructions, may cause harmful interference to radio communications. However, there is no guarantee that interference will not occur in a particular installation. If this equipment does cause harmful interference to radio or television reception, which can be determined by turning the equipment off and on, the user is encouraged to try to correct the interference by one or more of the following measures:

- Reorient or relocate the receiving antenna.
- Increase the separation between the equipment and receiver.
- Connect the equipment into an outlet on a circuit different from that to which the receiver is connected.
- Consult the dealer or an experienced radio/TV technician for help.
- The use of a non-shielded interface cable with the referenced device is prohibited.

CAUTION — The changes or modifications not expressly approved by the party responsible for compliance could void the user's authority to operate the equipment.

This device complies with Part 15 of FCC Rules and RSS-Gen of IC Rules.

Operation is subject to the following two conditions; (1) this device may not cause interference, and (2) this device must accept any interference, including interference that may cause undesired operation of the device.

* The above warning is valid only in the United States of America.

Safety Information

Laser Safety

This printer is certified as a Class 1 laser product under the U.S. Department of Health and Human Services (DHHS) Radiation Performance Standard according to Radiation Control for Health and Safety Act of 1968. This means that the printer does not produce hazardous laser radiation. Since radiation emitted inside the printer is completely confined within protective housings and external covers, the laser beam cannot escape from the printer during any phase of user operation.

Laser Notice

This printer is certified in the U.S. to conform to the requirements of DHHS 21 CFR Subchapter for Class I (1) laser products, and elsewhere is certified as a Class I laser product conforming to the requirements of IEC 825.



DANGER CLASS 3B INVISIBLE LASER RADIATION WHEN OPEN. AVOID DIRECT EXPOSURE TO BEAM.



CAUTION Use of controls or adjustments or performance of procedures other than those specified herein may result in hazardous radiation exposure.

Radio Frequency Transmitter

This machine contains a transmitter module. We, the manufacturer (Kyocera Mita Corporation) hereby declare that this equipment (page printer), model FS-1120D and FS-1320D are in compliance with the essential requirements and other relevant provisions of Directive 1999/5/EC.

Radio Tag Technology

In some countries, the radio tag technology used in this equipment to identify the toner container may be subject to authorization, and the use of this equipment may consequently be restricted.

Caution Labels

The printer bears any of the following labels.

Laser inside the printer
(Laser radiation warning)

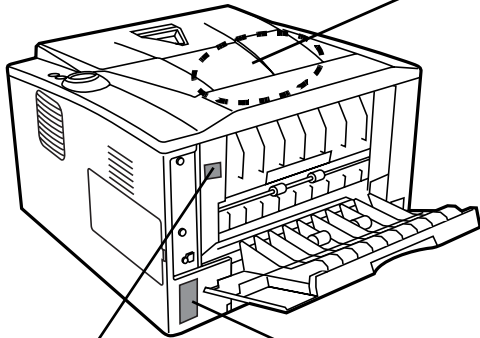

	<p>DANGER • CLASS 3B INVISIBLE LASER RADIATION WHEN OPEN. AVOID DIRECT EXPOSURE TO BEAM.</p> <p>ATTENTION • CLASSE 3B RAYONNEMENT LASER INVISIBLE EN CAS D'OUVERTURE. EXPOSITION DANGEREUSE AU FASCIAU.</p> <p>VORSICHT • KLASSE 3B UNSICHTBARE LASERSTRAHLUNG. WENN ABDECKUNG GEÖFFNET, NICHT DEM STRAHL AUSSETZEN.</p> <p>ATTENZIONE • CLASSE 3B RADIAZIONE LASER INVISIBLE IN CASO DI APERTURA. EVITARE L'ESPOSIZIONE AL FASCIO.</p> <p>PRECAUCION • CLASSE 3B RADIAZIONE LASER INVISIBLE CUANDO SE ABRE. EVITAR EXPOSERSE AL RAYO.</p> <p>VARO! • AVATTAESSA OLET ALTTINA LUOKAN 3B NÄKYMÄTTÖMÄLLE LASERSÄTELYLLE. ÄLÄ KATSO SÄTEESEEN.</p> <p>警告 • 该产品为3B类不可见激光产品。打开盖子后会有激光辐射。请避免光束照射。</p> <p>警告 • 該產品為3B類不可見激光產品。打開蓋子後會有激光輻射。請避免光束照射。</p> <p>위험 • CLASS 3B 용가시 레이저광선을 직접 보지마십시오.</p> <p>警告 • ここを覗くとクラス3B不可視レーザー光がでます。ビームを直接あたり、触れないでください。</p>
--	---

For Europe, Asia, and other countries

<p>CAUTION HOT SURFACE</p> <p>ACHTUNG HEISSE OBERFLÄCHE</p> <p>ATTENTION TEMPÉRATURE ÉLEVÉE</p> <p>ATTENZIONE ESTERIOR CALIENTE</p> <p>ATTENZIONE SUPERFICIE CHE SCOTIA</p> <p>高温注意</p> <p>고온주의</p>	
--	--

<p>FS-1120D AC 220-240V 50/60Hz 4.2A</p> <p>KYOCERA MITA Corporation</p> <p>• Apparat mit leitendes jordsidkonnakt.</p> <p>• Apparat skall anslutas till jordad uttag.</p> <p>• Laito on liitetty suojamaadoituskojektin lä viarusostuun pistoraasiaan.</p>	<p>CLASS 1 LASER PRODUCT KLASSE 1 LASER PRODUKT</p>
	<p>DESIGNED IN JAPAN / ASSEMBLED IN CHINA</p>

For U.S.A. and Canada

<p>FS-1320D AC 120V 60Hz 8.0A</p> <p>KYOCERA MITA Corporation</p> <p>TAMAKI PLANT</p> <p>704-19 NOJINO, TAMAKI-TOWN, WATARAI-COUNTY, MIE-PREF., JAPAN</p> <p>MANUFACTURED: C11</p>	<p>CLASS 2 LASER PRODUCT KLASSE 2 LASER PRODUKT</p>
<p>Complies with FDA radiation performance standards 21 CFR Subchapter J.</p> <p></p> <p>This device complies with Part 15 of the FCC Rules. Operation is subject to the following two conditions: (1) This device may not cause harmful interference, and (2) this device must accept any interference received, including interference that may cause undesired operation. FCC ID: E522HS0108</p> <p>This Class B digital apparatus complies with Canadian ICES-303.</p> <p>Cet appareil numérique de la classe B est conforme de la norme NMB-303 du Canada. IC: 1059B-2HS0108</p> <p>• REMOVE POWER CORD BEFORE SERVICE AND FUSE REPLACEMENT.</p> <p>• POUR PREVENIR LES CHOCS ELECTRIQUES, COUPER L'ALIMENTATION AVANT DE REMPLACER LE FUSIBLE.</p> <p>• REMOVE POWER CORD BEFORE SERVICE AND FUSE REPLACEMENT.</p> <p>• POUR PREVENIR LES CHOCS ELECTRIQUES, COUPER L'ALIMENTATION AVANT DE REMPLACER LE FUSIBLE.</p> <p>• REMOVE POWER CORD BEFORE SERVICE AND FUSE REPLACEMENT.</p> <p>• POUR PREVENIR LES CHOCS ELECTRIQUES, COUPER L'ALIMENTATION AVANT DE REMPLACER LE FUSIBLE.</p> <p>• REMOVE POWER CORD BEFORE SERVICE AND FUSE REPLACEMENT.</p> <p>• POUR PREVENIR LES CHOCS ELECTRIQUES, COUPER L'ALIMENTATION AVANT DE REMPLACER LE FUSIBLE.</p>	<p>DESIGNED IN JAPAN / ASSEMBLED IN CHINA</p>

CDRH Regulations

The Center for Devices and Radiological Health (CDRH) of the U.S. Food and Drug Administration implemented regulations for laser products on August 2, 1976. These regulations apply to laser products manufactured after August 1, 1976. Compliance is mandatory for products marketed in the United States. A label indicating compliance with the CDRH regulations must be attached to laser products marketed in the United States.

Ozone Concentration

These printers generate ozone gas (O₃), which may concentrate in the place of installation and cause an unpleasant smell. To minimize the concentration of ozone gas to less than 0.1ppm, we recommend you not to install the printer in a confined area where ventilation is blocked.



**DECLARATION OF CONFORMITY
TO**

2004/108/EC, 2006/95/EEC, 93/68/EEC, 1999/5/EC and 2009/125/EC

We declare under our sole responsibility that the product to which this declaration relates is in conformity with the following specifications.

EN55024

EN55022 Class B

EN61000-3-2

EN61000-3-3

EN60950-1

EN60825-1

EN300 330-1

EN300 330-2

EN62301

**Canadian Department of Communications
Compliance Statement**

This Class B digital apparatus complies with Canadian ICES-003.

**Avis de conformité aux normes du ministère
des Communications du Canada**

Cet appareil numérique de la classe B est conforme à la norme NMB-003 du Canada.

EN ISO 7779

Maschinenlärminformations-Verordnung 3. GPSGV, 06.01.2004: Der höchste Schalldruckpegel beträgt 70 dB (A) oder weniger gemäß EN ISO 7779.

EK1-ITB 2000

Das Gerät ist nicht für die Benutzung im unmittelbaren Gesichtsfeld am Bildschirmarbeitsplatz vorgesehen. Um störende Reflexionen am Bildschirmarbeitsplatz zu vermeiden, darf dieses Produkt nicht im unmittelbaren Gesichtsfeld platziert werden.

Disclaimer

Kyocera Mita will not be liable to customers or any other person or entity for any loss or damage caused or alleged to be caused directly or indirectly by equipment sold or furnished by us, including but not limited to, any interruption of service, loss of business or anticipatory profits, or consequential damages resulting from the use or operation of the equipment or software.

Safety Instructions Regarding the Disconnection of Power

Caution: The power plug is the main isolation device! Other switches on the equipment are only functional switches and are not suitable for isolating the equipment from the power source.

VORSICHT: Der Netzstecker ist die Hauptisoliervorrichtung! Die anderen Schalter auf dem Gerät sind nur Funktionsschalter und können nicht verwendet werden, um den Stromfluß im Gerät zu unterbrechen.

Energy Saving Function

This printer comes equipped with a Sleep Mode where printer function remains in a waiting state but power consumption is still reduced to a minimum when there is no activity with the printer within a set amount of time.

Sleep Mode

This printer automatically enters Sleep Mode when approximately 15 minutes have passed since the printer was last used. The amount of time of no activity that must pass before Sleep Mode is activated may be lengthened.

Duplex Printing

This printer includes duplex printing as a standard function. For example, by printing two single-sided originals onto a single sheet of paper as a duplex printing, it is possible to lower the amount of paper used.

Recycled Paper

This printer supports recycled paper which reduces the load on the environment. Your sales or service representative can provide information about recommended paper types.

Energy Star (ENERGY STAR®) Program



We have determined as a participating company in the International Energy Star Program that this product is compliant with the standards laid out in the International Energy Star Program.

Symbols

The sections of this guide and parts of the machine marked with symbols are safety warnings meant to protect the user, other individuals and surrounding objects, and ensure correct and safe usage of the machine. The symbols and their meanings are indicated below.



DANGER: Indicates that serious injury or even death will very possibly result from insufficient attention to or incorrect compliance with the related points.



WARNING: Indicates that serious injury or even death may result from insufficient attention to or incorrect compliance with the related points.



CAUTION: Indicates that personal injury or mechanical damage may result from insufficient attention to or incorrect compliance with the related points.

The following symbols indicate that the related section includes safety warnings. Specific points of attention are indicated inside the symbol.



.... [General warning]



.... [Warning of danger of electrical shock]



.... [Warning of high temperature]

The following symbols indicate that the related section includes information on prohibited actions. Specifics of the prohibited action are indicated inside the symbol.



.... [Warning of prohibited action]



.... [Disassembly prohibited]

The following symbols indicate that the related section includes information on actions which must be performed. Specifics of the required action are indicated inside the symbol.



.... [Alert of required action]



.... [Remove the power plug from the outlet]



.... [Always connect the machine to an outlet with a ground connection]

Please contact your service representative to order a replacement if the safety warnings in this Operation Guide are illegible or if the guide itself is missing. (fee required)

Installation Precautions

Environment

Caution

Avoid placing the machine on or in locations which are unstable or not level. Such locations may cause the machine to fall down or fall over. This type of situation presents a danger of personal injury or damage to the machine.



Avoid locations with humidity or dust and dirt. If dust or dirt become attached to the power plug, clean the plug to avoid the danger of fire or electrical shock.



Avoid locations near radiators, heaters, or other heat sources, or locations near flammable items, to avoid the danger of fire.



To keep the machine cool and facilitate changing of parts and maintenance, allow access space as shown below. Leave adequate space, especially around the rear cover, to allow air to be properly ventilated out of the printer.

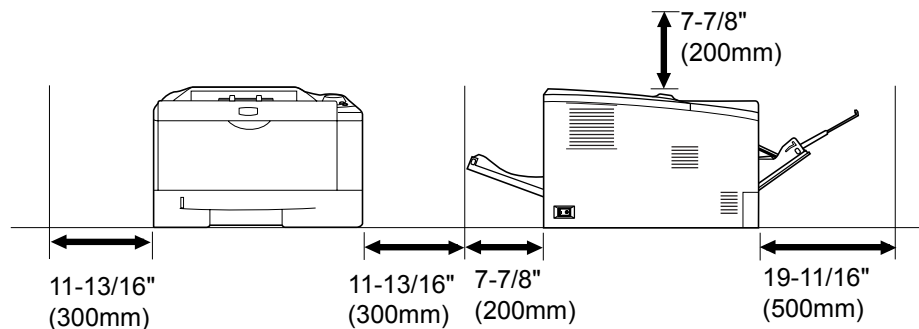

Other Precautions

Adverse environmental conditions may affect the safe operation and performance of the machine. Install in an air-conditioned room (recommended room temperature: around 23°C (73.4°F), humidity: around 60% RH), and avoid the following locations when selecting a site for the machine.

- Avoid locations near a window or with exposure to direct sunlight.
- Avoid locations with vibrations.
- Avoid locations with drastic temperature fluctuations.
- Avoid locations with direct exposure to hot or cold air.
- Avoid poorly ventilated locations.

During printing, some ozone is released, but the amount does not cause any ill effect to one's health. If, however, the printer is used over a long period of time in a poorly ventilated room or when printing an extremely large number of copies, the smell may become unpleasant. To maintain the appropriate environment for print work, it is suggested that the room be properly ventilated.

Power Supply/Grounding the Machine

Warning

Do not use a power supply with a voltage other than that specified. Avoid multiple connections in the same outlet. These types of situations present a danger of fire or electrical shock.



Plug the power cord securely into the outlet. If metallic objects come in contact with the prongs on the plug, it may cause a fire or electric shock.



Always connect the machine to an outlet with a ground connection to avoid the danger of fire or electrical shock in case of an electric short. If an earth connection is not possible, contact your service representative.



Other precautions

Connect the power plug to the closest outlet possible to the machine.

The power supply cord is used as the main disconnect device. Ensure that the socket/outlet is located/installed near the equipment and is easily accessible.

Handling of plastic bags

Warning

Keep the plastic bags that are used with the machine away from children. The plastic may cling to their nose and mouth causing suffocation.



Precautions for Use

Cautions when using the machine

Warning

Do not place metallic objects or containers with water (flower vases, flower pots, cups, etc.) on or near the machine. This situation presents a danger of fire or electrical shock should they fall inside.



Do not remove any of the covers from the machine as there is a danger of electrical shock from high voltage parts inside the machine.



Do not damage, break or attempt to repair the power cord. Do not place heavy objects on the cord, pull it, bend it unnecessarily or cause any other type of damage. These types of situations present a danger of fire or electrical shock.



Never attempt to repair or disassemble the machine or its parts as there is a danger of fire, electrical shock or damage to the laser. If the laser beam escapes, there is a danger of it causing blindness.



If the machine becomes excessively hot, smoke appears from the machine, there is an odd smell, or any other abnormal situation occurs, there is a danger of fire or electrical shock. Turn the main power switch off (O) immediately, be absolutely certain to remove the power plug from the outlet and then contact your service representative.



If anything harmful (paper clips, water, other fluids, etc.) falls into the machine, turn the main power switch off (O) immediately. Next, be absolutely certain to remove the power plug from the outlet to avoid the danger of fire or electrical shock. Then contact your service representative.



Do not remove or connect the power plug with wet hands, as there is a danger of electrical shock.



Always contact your service representative for maintenance or repair of internal parts.



Caution

Do not pull the power cord when removing it from the outlet. If the power cord is pulled, the wires may become broken and there is a danger of fire or electrical shock. (Always grasp the power plug when removing the power cord from the outlet.)



Always remove the power plug from the outlet when moving the machine. If the power cord is damaged, there is a danger of fire or electrical shock.



If the machine will not be used for a short period of time (overnight, etc.), turn the power switch off (O). If it will not be used for an extended period of time (vacations, etc.), remove the power plug from the outlet for safety purposes during the time the machine is not in use..



Always hold the designated parts only when lifting or moving the machine.



For safety purposes, always remove the power plug from the outlet when performing cleaning operations.



If dust accumulates within the machine, there is a danger of fire or other trouble. It is therefore recommended that you consult with your service representative in regard to cleaning of internal parts. This is particularly effective if accomplished prior to seasons of high humidity. Consult with your service representative in regard to the cost of cleaning the internal parts of the machine.



Other precautions

Do not place heavy objects on the machine or cause other damage to the machine.

Do not open the upper front cover, turn off the main power switch, or pull out the power plug during printing.

When lifting or moving the machine, contact your service representative.

Do not touch electrical parts, such as connectors or printed circuit boards. They could be damaged by static electricity.

Do not attempt to perform any operations not explained in this handbook.

Use shielded interface cables.

Caution

Use of controls or adjustments or performance of procedures other than those specified herein may result in hazardous radiation exposure.

Cautions when Handling Consumables

Caution

Do not attempt to incinerate the Toner Container. Dangerous sparks may cause burns.



Keep the Toner Container out of the reach of children.



If toner happens to spill from the Toner Container, avoid inhalation and ingestion, as well as contact with your eyes and skin.



- If you do happen to inhale toner, move to a place with fresh air and gargle thoroughly with a large amount of water. If coughing develops, contact a physician.
- If you do happen to ingest toner, rinse your mouth out with water and drink 1 or 2 cups of water to dilute the contents of your stomach. If necessary, contact a physician.
- If you do happen to get toner in your eyes, flush them thoroughly with water. If there is any remaining tenderness, contact a physician.
- If toner does happen to get on your skin, wash with soap and water.

Do not attempt to force open or destroy the Toner Container.



Other precautions

After use, always dispose of the Toner Container in accordance with Federal, State and Local rules and regulations.

Store all consumables in a cool, dark location.

If the machine will not be used for an extended period of time, remove the paper from the cassette, return it to its original package and reseal it.

About the Operation Guide

This Operation Guide contains the following chapters:

1 Machine Parts

This chapter explains the names of parts.

2 Loading Paper

This chapter explains paper specifications for this printer and how to load paper into the cassette or MP tray.

3 Printing

This chapter explains how to install the printer driver, print from your PC, and use the application software included in the CD-ROM.

4 Maintenance

This chapter explains how to replace the toner container and how to care for your printer.

5 Troubleshooting

This chapter explains how to handle printer problems that may occur, such as paper jams.

6 Options

This chapter explains the options for this printer.

7 Specifications

This chapter lists the specifications of this printer.

Conventions in This Guide

This manual uses the following conventions.

Convention	Description	Example
Italic Typeface	Used to emphasize a key word, phrase or reference to additional information.	Refer to <i>Configuration Tool</i> on page 3-9.
Bold	Used to denote buttons on the software.	To start printing, click OK .
Bracket Bold	Used to denote operation panel keys.	Printing resumes when [GO] is pressed.
Note	Used to provide additional or useful information about a function or feature.	 Note Do not remove the toner container from the carton until you are ready to install it in the printer.
Important	Used to provide important information.	IMPORTANT Take care not to touch the transfer roller (black) during cleaning.
Caution	Cautions are statements that suggest mechanical damage as a result of an action.	CAUTION When pulling the paper, pull it gently so as not to tear it. Torn pieces of paper are difficult to remove and may be easily overlooked, deterring the paper jam recovery.
Warning	Used to alert users to the possibility of personal injury.	WARNING If you ship the printer, remove and pack the developer unit and drum unit in a plastic bag and ship them separately from the printer.

1 Machine Parts

This chapter identifies machine parts, indicators, and operation panel keys.

Components at the Front of the Printer	1-2
Components at the Rear of the Printer	1-3
Operation Panel	1-4
Indicators	1-5
Keys	1-6

Components at the Front of the Printer

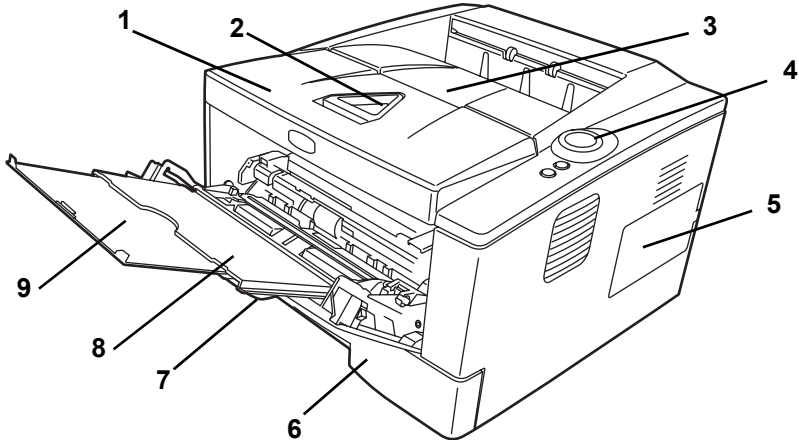

- 1 Top Cover
- 2 Paper Stopper
- 3 Top Tray
- 4 Operation Panel
- 5 Right Cover
- 6 Paper Cassette
- 7 Front Cover
- 8 MP Tray
- 9 Subtray

Components at the Rear of the Printer

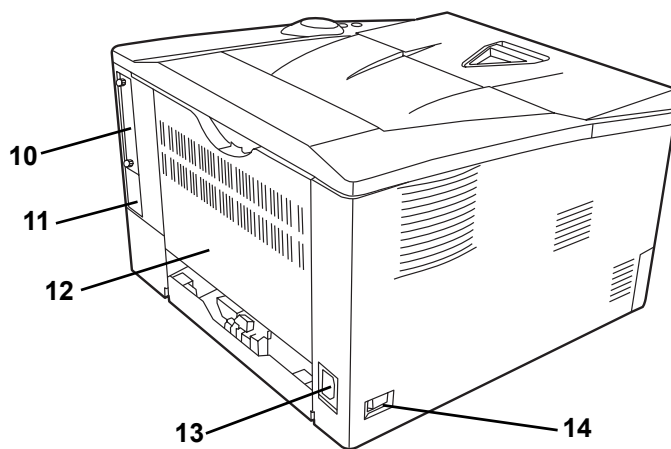

- 10** Optional Interface Slot Cover
- 11** USB Interface Connector
- 12** Rear Cover
- 13** Power Cord Connector
- 14** Power Switch



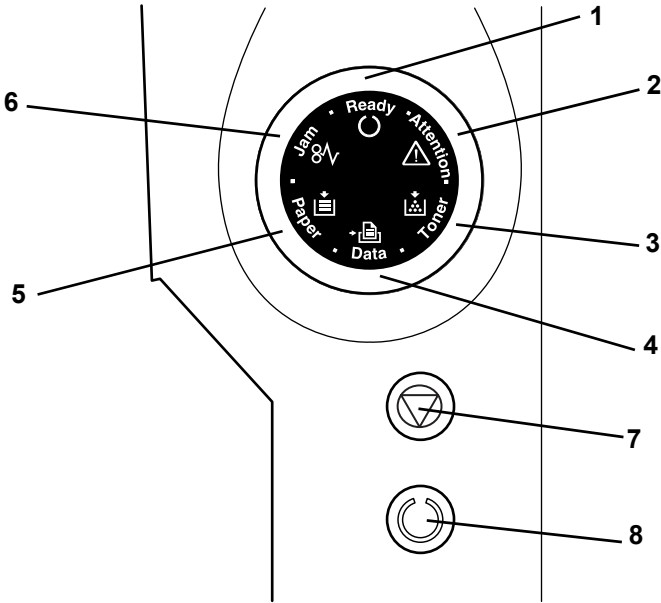



Operation Panel



- 1 **Ready** Indicator
- 2 **Attention** Indicator
- 3 **Toner** Indicator
- 4 **Data** Indicator
- 5 **Paper** Indicator
- 6 **Jam** Indicator
- 7 **[Cancel]** Key
- 8 **[GO]** Key

Indicators

There are six indicators located on the top right of the printer. The indicators are used to identify the status of the printer at any time. To identify the printer status, check the indicators on the printer and then refer to the table below.

Indicator	Status	Meaning
	Lit	Indicates online status (printing is possible).
	Fast Flashing	Offline status. You cannot print, but the printer can receive data.
	Slow Flashing	The printer is in sleep mode.
	Off	The printer has stopped because an error occurred.
	Lit	The printer is processing data or is accessing to memory.
	Fast Flashing	The printer is receiving data.
	Off	The printer is not processing data.
	Lit	A paper jam has occurred or the cassette is not inserted properly.
	Off	The printer status is normal.
	Lit	The paper has run out when printing.
	Fast Flashing	The specified cassette or paper feeder has no paper at Ready status. The cassette is not inserted properly.
	Off	The printer status is normal.
	Lit	An error has occurred because the top printer cover is open. While an optional paper feeder (PF-100) is installed and the feeder is selected as a paper source, the paper cassette of the main unit (CASS1) is not installed correctly.
	Fast Flashing	The warning status other than Jam, Toner, Paper, and Attention.
	Off	The printer status is normal.
	Lit	The printer has stopped because the toner is exhausted.
	Fast Flashing	The toner is running low.
	Off	The printer status is normal.



Note For other combinations of the six indicators, call for service. *Status Monitor* (software bundled with the *KX Driver*) will provide more detailed information about the printer status.

Keys

Refer to the following table for the name and description of the basic functions of each key.

Key	Status	Operation	Function
Cancel	-	Press for 1 second or more	Cancels the data from the PC
GO	At Ready	Press momentarily	Switches On-line/Off-line
		Press for 3 to 9 seconds	Prints the status page.
		Press for 10 seconds or more	Prints the service status page.
	At Error	Press momentarily	Clears the error.
Paper Empty	Press momentarily	Resumes printing by switching automatically to an available paper source.	

2 Loading Paper

This chapter explains paper specifications for this printer and how to load paper into the cassette or MP tray.

General Guidelines	2-2
Selecting the Right Paper	2-4
Paper Type	2-10
Preparing the Paper	2-11
Loading Paper into Cassette	2-11
Loading Paper into MP (Multi-Purpose)Tray	2-14

General Guidelines

The machine is designed to print on standard copier paper, but it can also accept a variety of other types of paper within the limits specified below.



Note The manufacturer assumes no liability for problems that occur when paper not satisfying these requirements is used.

Selection of the right paper is important. Using the wrong paper can result in paper jams, curling, poor print quality, and paper waste, and in extreme cases can damage the machine. The guidelines given below will increase the productivity of your office by ensuring efficient, trouble-free printing and reducing wear and tear on the machine.

Paper Availability

Most types of paper are compatible with a variety of machines. Paper intended for xerographic copiers can also be used with the machine.

There are three general grades of paper: economy, standard, and premium. The most significant difference between grades is the ease with which they pass through the machine. This is affected by the smoothness, size, and moisture content of the paper, and the way in which the paper is cut. The higher the grade of paper you use, the less risk there will be of paper jams and other problems, and the higher the level of quality your printed output will reflect.

Differences between paper from different suppliers can also affect the machine's performance. A high-quality printer cannot produce high-quality results when the wrong paper is used. Low-priced paper is not economical in the long run if it causes printing problems.

Paper in each grade is available in a range of basis weights (defined later). The traditional standard weights are 60 to 120 g/m² (16 to 31.9b).

Paper Specifications

The following table summarizes the basic paper specifications. Details are given on the following pages:

Item	Specifications
Weight	Cassette: 60 to 120 g/m ² (16 to 31.9 lb/ream) MP tray: 60 to 220 g/m ² (16 to 58.5 lb/ream)
Thickness	0.086 to 0.110mm (3.4 to 4.3 mils)
Dimensional Accuracy	±0.7 mm (±0.0276 inches)
Squareness of Corners	90±0.2°
Moisture Content	4 to 6%
Direction of Grain	Long grain
Pulp Content	80% or more

Minimum and Maximum Paper Sizes

The minimum and maximum paper sizes are as follows. For the paper smaller than JIS B6, postcards, and envelopes, the MP tray must be used.

Paper cassette

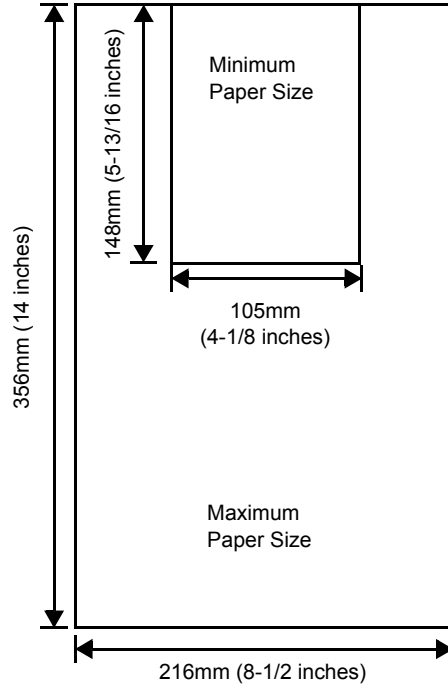

MP tray

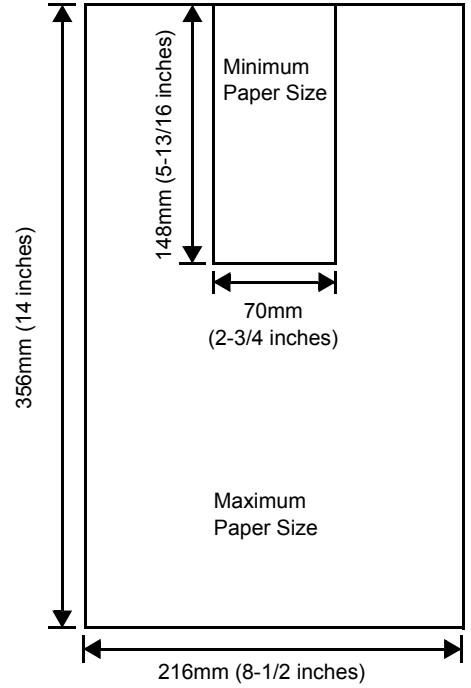

Note The minimum paper size of the optional paper feeder (PF-100) is 148 x 210 mm (5-13/16 x 8-5/16 inches).

Selecting the Right Paper

This section describes the guidelines for selecting paper.

Condition

Avoid using paper that is bent at the edges, curled, dirty, torn, embossed, or contaminated with lint, clay, or paper shreds.

Use of paper in these conditions can lead to illegible printing and paper jams, and can shorten the life of the machine. In particular, avoid using paper with a surface coating or other surface treatment. Paper should have as smooth and even a surface as possible.

Composition

Do not use paper that has been coated or surface-treated and contains plastic or carbon. The heat of fusing can cause such paper to give off harmful fumes.

Bond paper should contain at least 80% pulp. Not more than 20% of the total paper content should consist of cotton or other fibers.

Paper Sizes

Cassettes and the MP Tray are available for the paper sizes shown below. The dimensional tolerances are $\pm 0.7\text{mm}$ for the length and width. The angle at the corners must be $90^\circ \pm 0.2^\circ$.

MP Tray:

Envelope Monarch, Envelope #10, Envelope #9, Envelope #6, Envelope C5, Envelope DL, Legal, Letter, Statement, Oficio II, Executive, ISO A4, ISO A5, ISO A6, Folio, ISO B5, JIS B5, JIS B6, Hagaki, Ofuku-Hagaki, Youkei 2, Youkei 4, 16 kai, Custom (70 × 148 to 216 × 356mm (2-13/16 × 5-13/16 to 8-1/2 × 14 inches))



Note If the length of custom paper is larger than 297mm (11-11/16 inches), the printer can be specified ISO A4, Oficio II, Folio, and Legal as the standard paper size.

Cassette:

Legal, Letter, Statement, Oficio II, Executive, ISO A4, ISO A5, A6 (only for machine's paper cassette), Folio, ISO B5, JIS B5, Envelope C5, 16 kai, Custom (Paper Cassette: 105 × 148 to 216 × 356mm (4-1/8 × 5-13/16 to 8-1/2 × 14 inches), Paper Feeder: 148 × 210 to 216 × 356mm (5-13/16 × 8-5/16 to 8-1/2 × 14 inches))



Note If the length of custom paper is larger than 297mm (11-11/16 inches), the printer can be specified ISO A4, Oficio II, Folio, and Legal as the standard paper size.

Smoothness

The paper should have a smooth, uncoated surface. Paper with a rough or sandy surface can cause blank spaces in the printed output. Paper that is too smooth can cause multiple feeding and fogging problems. (Fogging is a gray background effect.)

Basis weight

Basis weight is the weight of paper expressed in grams per square meter (g/m²). Paper that is too heavy or too light may cause feed errors or paper jams as well as premature wear of the product. Uneven weight of paper, namely uneven paper thickness may cause multiple-sheet feeding or print quality problems such as blurring because of poor toner fusing.

The recommended basis weight is between 60 and 120g/m² (16 to 31.9 lib/ream) for the cassette and between 60 and 220g/m² (16 to 59 lib/ream) for the MP tray.

Paper Weight Equivalence Table

The paper weight is listed in pounds (lb) and metric grams per square meter (g/m²). The shaded part indicates the standard weight.

U. S. Bond Weight (lb)	Europe Metric Weight (g/m ²)
16	60
17	64
20	75
21	80
22	81
24	90
27	100
28	105
32	120
34	128
36	135
39	148
42	157
43	163
47	176
53	199

Thickness

The paper used with the machine should be neither extremely thick nor extremely thin. If you are having problems with paper jams, multiple feeds, and faint printing, the paper you are using may be too thin. If you are having problems with paper jams and blurred printing the paper may be too thick. The correct thickness is 0.086 to 0.110mm (3.4 to 4.3 mils).

Moisture Content

Moisture content is defined as the percent ratio of moisture to the dry mass of the paper. Moisture can affect the paper's appearance, feed ability, curl, electrostatic properties, and toner fusing characteristics.

The moisture content of the paper varies with the relative humidity in the room. When the relative humidity is high and the paper absorbs moisture, the paper edges expand, becoming wavy in appearance. When the relative humidity is low and the paper loses moisture, the edges shrink and tighten, and print contrast may suffer.

Wavy or tight edges can cause jams and alignment anomalies. The moisture content of the paper should be 4 to 6%.

To ensure correct moisture content, it is important to store the paper in a controlled environment. Some tips on moisture control are:

- Store paper in a cool, dry location.
- Keep the paper in its wrapping as long as possible. Re-wrap paper that is not in use.
- Store paper in its original carton. Place a pallet etc. under the carton to separate it from the floor.
- After removing paper from storage, let it stand in the same room as the machine for 48 hours before use.
- Avoid leaving paper where it is exposed to heat, sunlight, or damp.

Paper Grain

When paper is manufactured, it is cut into sheets with the grain running parallel to the length (long grain) or parallel to the width (short grain). Short grain paper can cause feeding problems in the machine. All paper used in the machine should be long grain.

Other Paper Properties

Porosity: Indicates the density of paper fiber.

Stiffness: Limp paper may buckle in the machine, resulting in paper jams.

Curl: Most paper naturally tends to curl one way if left unpacked. When paper passes through the fixing unit, it curls upward a little. To produce flat printouts, load the paper so that the upward pressure from the machine can correct their curling.

Electrostatic discharge: During the printing process the paper is electrostatically charged to attract the toner. The paper must be able to release this charge so that printed sheets do not cling together in the Output Tray.

Whiteness: The contrast of the printed page depends on the whiteness of the paper. Whiter paper provides a sharper, brighter appearance.

Quality control: Uneven sheet size, corners that are not square, ragged edges, welded (uncut) sheets, and crushed edges and corners can cause the machine to malfunction in various ways. A quality paper supplier should take considerable care to ensure that these problems do not occur.

Packaging: Paper should be packed in a sturdy carton to protect it from damage during transport. Quality paper obtained from a reputable supplier is usually correctly packaged.

Special Paper

The following types of special paper can be used:

- Thin paper (60 to 64 g/m²)
- Thick paper (90 to 220 g/m²)
- Colored paper
- Recycled paper
- Overhead projector transparencies
- Cardstock
- Coated paper
- Envelopes
- Labels

Use paper that is sold specifically for use with copiers or printers (heat-fusing type). When using transparencies, labels, envelopes, cardstock, coated, or thick paper, feed the paper from the MP Tray.

Since the composition and quality of special paper vary considerably, special paper is more likely than white bond paper to give trouble during printing. No liability will be assumed if moisture and so forth given off during printing on special paper causes harm to the machine or operator.



Note Before purchasing any type of special paper, test a sample on the machine and check that printing quality is satisfactory.

Half speed mode is automatically engaged depending on **Media types**, including **Labels**, **Rough**, and **Thick**.

Transparency

This printer is available for monochrome printing on transparencies. Transparencies must be fed to the MP Tray. One transparency can be loaded at a time.

Transparencies must be able to withstand the heat of fusing during the printing process.

Transparencies must be placed on the MP tray with the long edge towards the printer.

Labels

Labels must be fed to the MP Tray. One label can be loaded at a time.

The basic rule for printing on adhesive labels is that the adhesive must never come into contact with any part of the machine. Adhesive paper sticking to the drum or rollers will damage the machine.

Label paper has a structure comprising of three layers, as shown in the diagram. The top sheet is printed on. The adhesive layer consists of pressure-sensitive adhesives. The carrier sheet (also called the linear or backing sheet) holds the labels until used.

Due to the complexity of its composition, adhesive-

backed label paper is particularly likely to give printing problems.

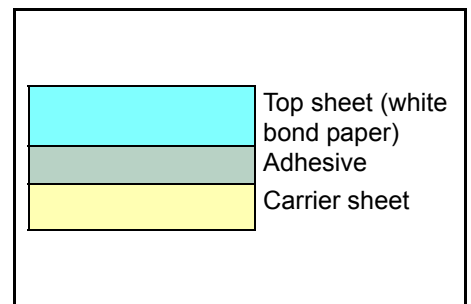

Adhesive label paper must be entirely covered by its top sheet, with no spaces between the individual labels. Labels with spaces in between are liable to peel off, causing serious paper jam problems.

Some label paper is manufactured with an extra margin of top sheet around the edge. Do not remove the extra top sheet from the carrier sheet until after printing is finished.

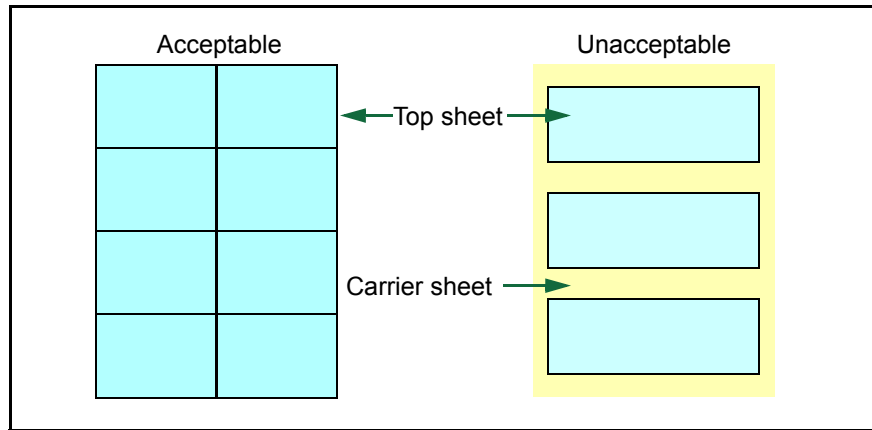

The table below lists the specifications for adhesive label paper.

Item	Specification
Weight of top sheet	44 to 74g/m ² (12 to 20 lb/ream)
Composite weight	104 to 151g/m ² (28 to 40 lb/ream)
Thickness of top sheet	0.086 to 0.107mm (3.9 to 4.2 mils)
Composite thickness	0.115 to 0.145mm (4.5 to 5.7 mils)
Moisture content	4 to 6% (composite)

Postcards

Up to 10 postcards can be loaded at a time. Fan the stack of postcards and align the edges before loading them in the MP tray. Make sure the postcards you are going to set are not curled. Feeding curled postcards may cause paper jams.

Some postcards have rough edges on the back (those are created when the paper is cut). In this case, put the postcards on a flat place and rub the edges with, for example, a ruler to smooth them.

Envelopes

Up to 5 envelopes can be loaded at a time. Envelopes should be fed in the face-up position, right edge first.

Since the composition of an envelope is more complex than that of ordinary paper, it is not always possible to ensure consistent printing quality over the entire envelope surface.

Normally, envelopes have a diagonal grain direction. Refer to *Paper Grain* on page 2-6. This direction can easily cause wrinkles and creases when envelopes pass through the printer. Before purchasing envelopes, make a test print to check whether the printer accepts the envelope.

- Do not use envelopes that have an encapsulated liquid adhesive.
- Avoid a long printing session for envelopes only. Extended envelope printing can cause premature printer wear.
- If jams occur, try setting less envelopes on the MP tray.
- To avoid jams caused by curled envelopes, stack no more than 10 printed envelopes on the output tray.

Thick Paper

Fan the stack of paper and align the edges before loading them in the MP tray. Some types of paper have rough edges on the back (those are created when the paper is cut). In this case, put the paper on a flat place and rub the edges once or twice with, for example, a ruler to smooth them. Feeding rough edged paper may cause paper jams.



Note If the paper jams even after you smooth it out, load the paper in the MP Tray with the leading edge raised up a few millimeters as shown in the illustration.

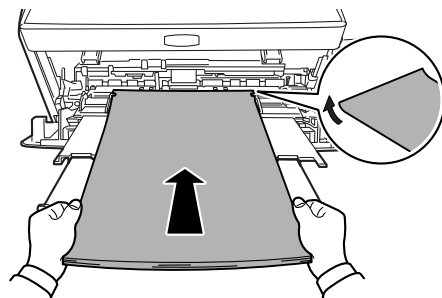

Colored Paper

Colored paper should satisfy the same conditions as white bond paper. Refer to *Paper Specifications* on page 2-2. In addition, the pigments used in the paper must be able to withstand the heat of fusing during the printing process (up to 200°C or 392°F).

Preprinted Paper

Preprinted paper should satisfy the same conditions as white bond paper. Refer to *Paper Specifications* on page 2-2. The preprinted ink must be able to withstand the heat of fusing during the printing process, and must not be affected by silicone oil.

Do not use paper with any kind of surface treatment, such as the type of paper commonly used for calendars.

Recycled paper

Select recycled paper that meets the same specifications as the white bond paper except for whiteness. Refer to *Paper Specifications* on page 2-2.



Note Before purchasing recycled paper, test a sample on the machine and check that the printing quality is satisfactory.

Paper Type

The printer is capable of printing under the optimum setting for the type of paper being used.

A different paper type setting can be made for each paper source including the MP tray. Not only can preset paper types be selected, but it is also possible for you to define and select customized paper types. Paper type can be changed using the printer driver and Configuration Tool. The following types of paper can be used.

Paper Type	Paper source		
	MP tray	Paper Cassette	Duplex path (MP tray available only in Cassette mode)
Plain	Yes	Yes	Yes
Transparency	Yes	No	No
Preprinted	Yes	Yes	Yes
Labels	Yes	No	No
Bond	Yes	Yes	Yes
Recycled	Yes	Yes	Yes
Vellum	Yes	No	No
Rough	Yes	Yes	Yes
Letterhead	Yes	Yes	No
Color	Yes	Yes	Yes
Prepunched	Yes	Yes	Yes
Envelope	Yes	No	No
Cardstock	Yes	No	No
Thick	Yes	No	No
High quality	Yes	Yes	Yes
Custom 1 (to 8)*	Yes	Yes	Yes

Yes: Can be stored No: Cannot be stored

- *. This is a paper type defined and registered by the user. Up to eight types of user settings may be defined. User can also enable or disable the duplex path when using Custom. For more information, refer to *Status Monitor* on page 3-10.

Preparing the Paper

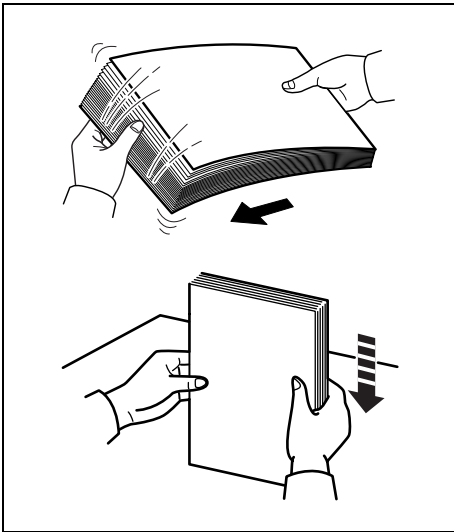

After removing paper from the packaging, fan through the sheets to separate them prior to loading.

If using paper that has been folded or is curled, straighten it prior to loading. Failure to do so may result in a paper jam.

IMPORTANT Ensure paper is not stapled and clips are removed.

Loading Paper into Cassette

250 sheets of 11 × 8 1/2" or A4 paper (80 g/m²) may be loaded into the Cassette.

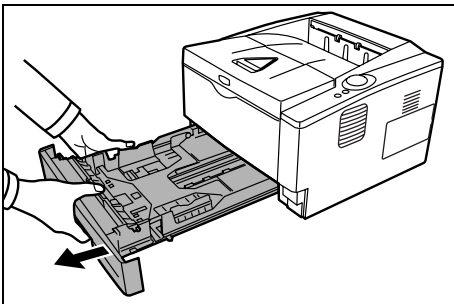

1 Pull the cassette completely out of the printer.

IMPORTANT When pulling the cassette out of the printer, ensure it is supported and does not fall out.

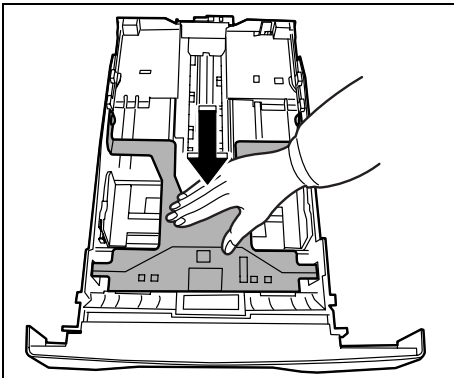

2 Press the bottom plate down until it locks.

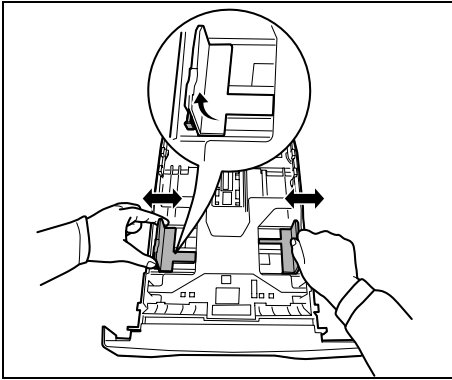

3 Adjust the position of the width guides located on the left and right sides of the cassette. Press the release button on the left guide and slide the guides to the paper size required.



Note Paper sizes are marked on the cassette.

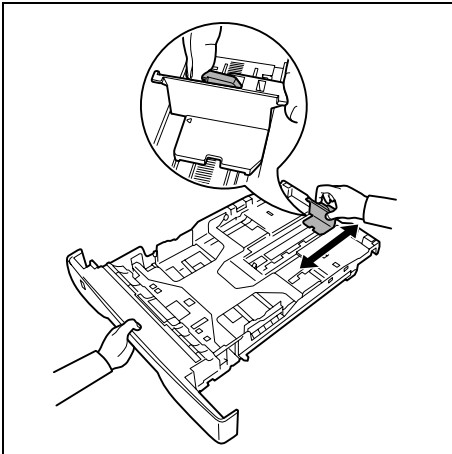

4 Adjust the paper length guide to the paper size required.

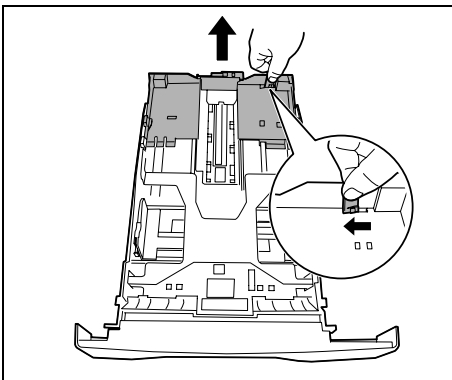

If you are going to use paper that is longer than A4, pull out the extension paper cassette by pushing the release lever one by one and adjust it to the desired paper size.

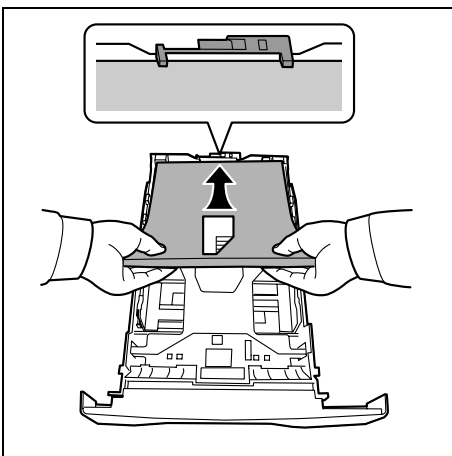

5 Load the paper in the cassette. Ensure the side to be printed is facing down and the paper is not folded, curled, or damaged.

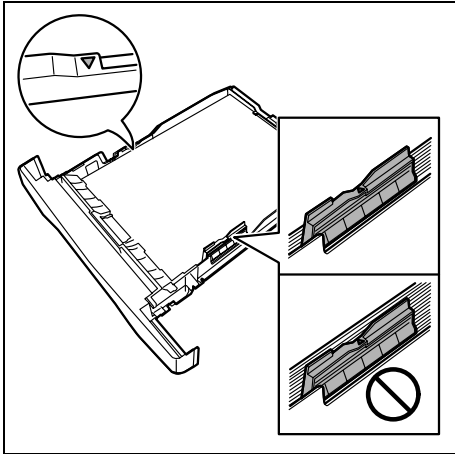

Note Do not load paper above the triangle mark located on the width guide.

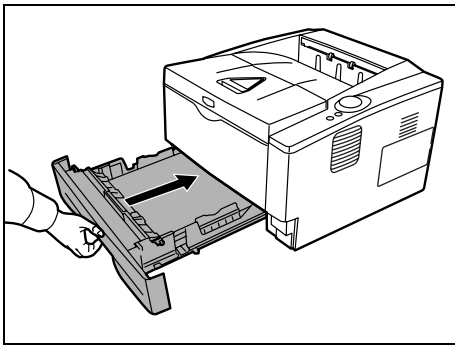

- 6** Insert the paper cassette into the slot in the printer. Push it straight in as far as it will go.

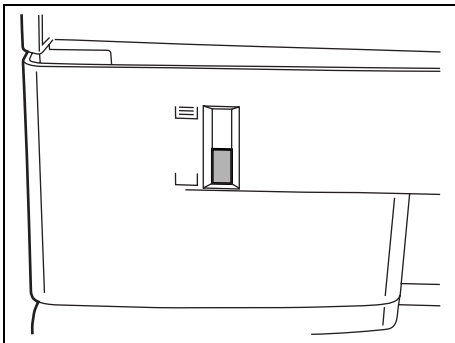

There is a paper gauge on the left side of the front of the paper cassette to indicate the remaining paper supply. When paper is exhausted, the pointer will go down to the level of (empty).

- 7** Specify the paper size and type for the *cassette* using Configuration Tool. For more information, refer to *Configuration Tool* on page 3-14.

Loading Paper into MP (Multi-Purpose)Tray

This machine can load up to 50 sheets of 11 × 8 1/2" or A4 paper (80 g/m²) into the MP Tray.

- 1 Pull the MP tray towards you until it stops.

IMPORTANT When pulling the cassette out of the printer, ensure it is supported and does not fall out.

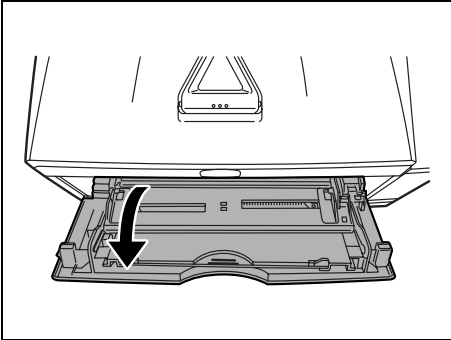

- 2 Adjust the position of the paper guides on the MP tray. Standard paper sizes are marked on the MP tray. For standard paper sizes, slide the paper guides to the corresponding mark.

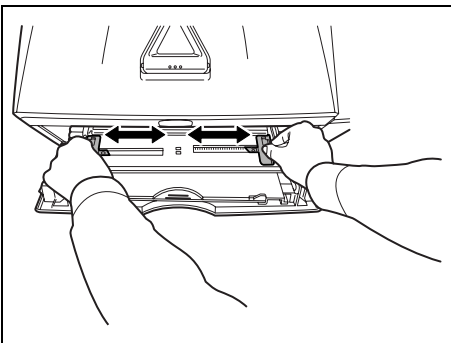

- 3 Pull out the subtray.

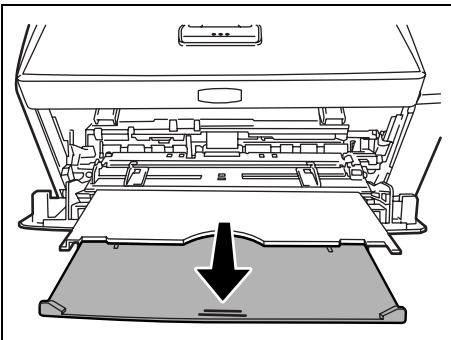



- 4 Align the paper with the paper guides and insert as far as it will go.

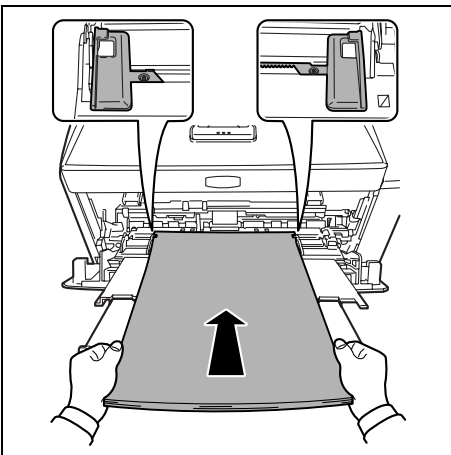

Note Do not load more paper than exceeds the tab of the MP tray.

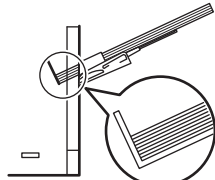
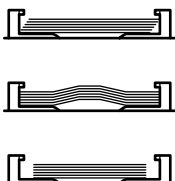
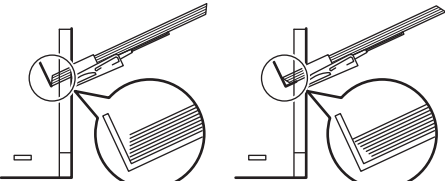

 **Note** If the paper is considerably curled in one direction, for example, if the paper is already printed on one side, try to roll the paper in the opposite direction to counteract the curl. Printed sheets will then come out flat.

Correct		
Incorrect		

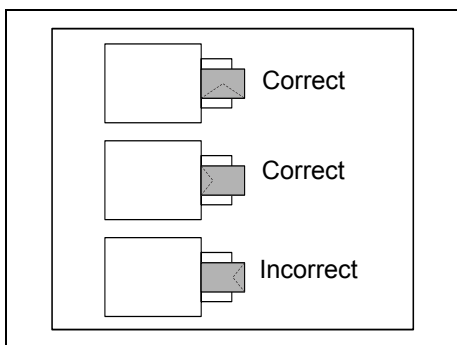

When loading envelope, place with the envelope flap closed and keep the printing side face-up. Insert envelope against the guide with the flap on the front or left side until they stop.

- 5 Specify the paper size and type for MP tray using Configuration Tool. For more information, refer to *Configuration Tool* on page 3-14.

Paper Stopper

Open the paper stopper shown in the figure.

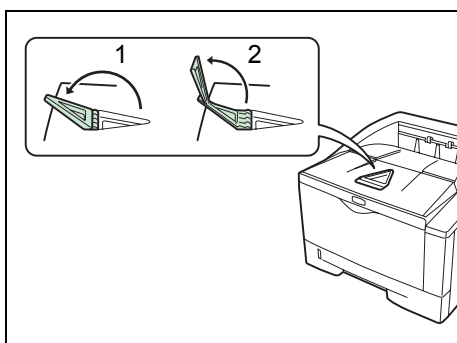

3 Connecting and Printing

This chapter explains how to start up the printer, print from your PC, and use the application software included in the CD-ROM.

Connections	3-2
Installing the Printer Driver	3-3
Printing	3-9
Status Monitor	3-10
Configuration Tool	3-14
Uninstalling Software (Windows PC)	3-18

Connections

This section explains how to start up the printer.

Connecting the USB Cable

Follow the steps as below for connecting the USB cable.

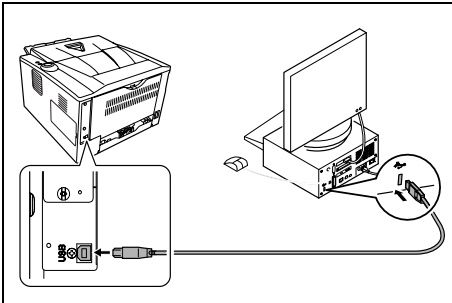

- 1 Connect the USB cable (not included) to the USB Interface Connector.



Note Use a USB cable with a rectangular Type A plug and a square Type B plug. The USB cable should be shielded and no longer than 5 meters (16 feet) long.

- 2 Connect the other end of the USB cable to the computer's USB interface connector.

Connecting the Power Cord

Install the printer close to an AC wall outlet. If an extension cord is used, the total length of the power cord plus extension should be 5 meters (16 feet) or less.



Note Ensure the printer's power switch is off. Only use the power cord supplied with the printer.

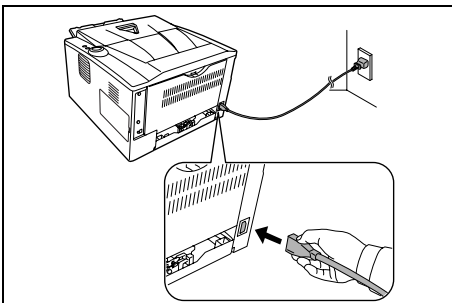

- 1 Connect the power cord to the Power Cord Connector at the rear of the printer.

- 2 Connect the other end of the power cord to a power outlet.

- 3 Press the Power Switch to On (|). The printer begins to warm up.

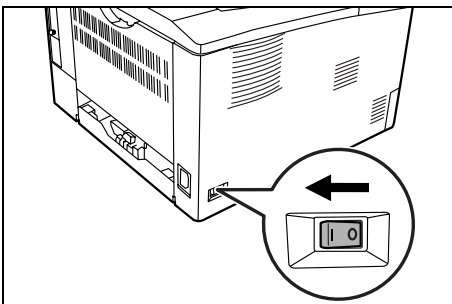

IMPORTANT If you install the toner container and switch on the power, after a moment the indicators light in anticlockwise direction. When the printer is first switched on after toner installation, there will be a delay of approximately 15 minutes before the printer gets ready to print. Once the **[Ready]** indicator lights, printer installation is complete.

Installing the Printer Driver

Ensure the printer is plugged in and connected to the PC before installing the printer driver from the CD-ROM.

Installing the Software in Windows

If you are connecting this printer to a Windows PC, follow the next steps to install the printer driver. The example shows you how to connect your printer to a Windows Vista PC.



Note In Windows operating systems, you must be logged in with administrator rights to install the printer driver.

You can use either Express Mode or Custom Mode to install the software. Express Mode automatically detects connected printers and installs the required software. Use Custom Mode if you want to specify the printer port and select the software to be installed.

- 1 Turn on the computer and start up Windows.

If the Welcome to the Found New Hardware Wizard dialog box displays, select **Cancel**.

- 2 Insert the CD-ROM supplied with the printer into the optical drive of the PC. In Windows 7, Windows Server 2008 and Windows Vista, the user account control window may appear. Click **Allow**.

The installation program launches.



Note If the software install wizard does not launch automatically, open the CD-ROM window in Windows Explorer and double-click **Setup.exe**.

- 3 Click **View License Agreement** and read the License Agreement. Click **Accept**.



- 4 Click **Install software**.

The software install wizard starts up.

From this point, the procedure differs depending on your version of Windows and your connection method. Proceed to the correct procedure for your connection type.

- Express Mode
- Custom Mode

Express Mode

In Express Mode, the installer automatically detects the printer when it is turned on. Use Express Mode for standard connection methods.



- 1 In the installation method selection window, select **Express Mode**. The print system detection window appears and the installer detects the connected printers. If the installer does not detect a print system, check that the print system is connected via USB or a network and that it is turned on. Then click **Refresh** to search print system again.

 **Note** While the information shown in Windows Vista and Windows 7/Windows XP installation dialog boxes differs slightly, the installation procedure is the same.

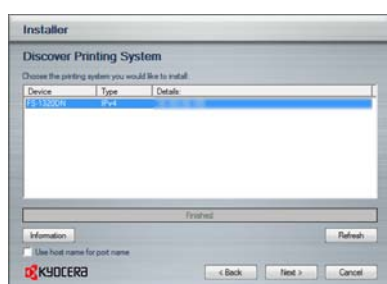

- 2 Select the printer you want to be installed, and click **Next**.

 **Note** If the Found New Hardware Wizard appears, click **Cancel**. If a hardware installation warning message appear, click **Continue**.



- 3 You can customize the print system name in the installation settings window. This will be the name displayed in the Printer window and in the printer lists displayed in applications. Specify whether to share the print system name or set the print system as an existing printer and then click **Next**.

IMPORTANT Step 3 only appears if the print system is connected via a network. It does not appear if the print system is connected via a USB at the time of the first installation.

- 4 A window appears in which you can check the settings. Check the settings carefully and then click **Install**.

 **Note** If the Windows security window appears, click **Install this driver software anyway**.

- 5 A message appears saying that the printer has been installed successfully. Click **Finish** to exit the printer installation wizard and return the CD-ROM main menu.

If the device setup dialog box appears after you click **Finish**, you can specify the settings for items such as optional features installed in the print system. You can also specify the device settings after you exit the installation. For details, refer to Device Settings in the printer driver operation manual on the CD-ROM.

This completes the printer driver installation procedure. Follow the on-screen instructions to restart the system, if required.

Custom Mode

Use Custom Mode if you want to specify the printer port and select the software to be installed.

For example, if you do not want fonts installed on your computer to be replaced, select **Custom Mode** and deselect the **Fonts** checkbox in the utility tab.

1 Select **Custom Mode**.



2 Following the instructions in the install wizard window, select the software packages to be installed and the specify the port, etc.

For details, refer to *Custom Installation* in the printer driver operation manual on the CD-ROM.

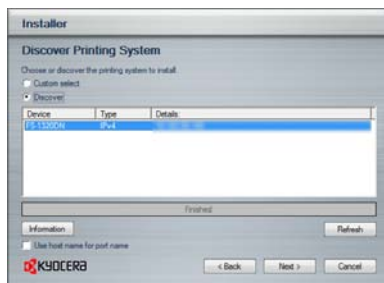

Installation on a Macintosh

This section explains how to install the printer driver in Mac OS.

- 1 Turn on the printer and the Macintosh.
- 2 Insert the included CD-ROM (**Product Library**) into the CD-ROM drive.
- 3 Double-click the CD-ROM icon.
- 4 Double-click either **OS X 10.2 and 10.3 Only**, **OS X 10.4 Only** or **OS X 10.5 or higher** depending on your Mac OS version.



5 Double-click **Kyocera OS X x.x.**



6 The printer driver installation program starts up.



7 Choose **Select Destination, Installation Type** and then install the printer driver as directed by the instructions in the installation software.

 **Note** In addition to **Easy Install**, the **Installation Type** options include **Custom Install**, which allows you to specify the components to be installed.

IMPORTANT In the Authenticate screen, enter the name and password used to log in to the operating system.

This completes the printer driver installation. Next, specify the print settings.

If an IP, AppleTalk or Bonjour connection is used, the settings below are required. If a USB connection is used, the printer is automatically recognized and connected.

8 Open **System Preferences** and click **Print & Fax**.





9 Click the plus symbol (+) to add the installed printer driver.

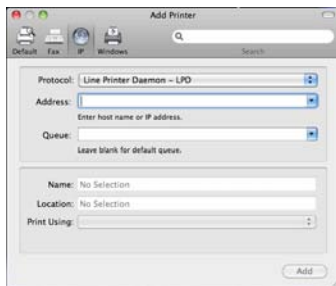

10 Click the IP icon for an IP connection and then enter the IP address and printer name.

When you click the AppleTalk icon for an AppleTalk connection, enter the printer name.

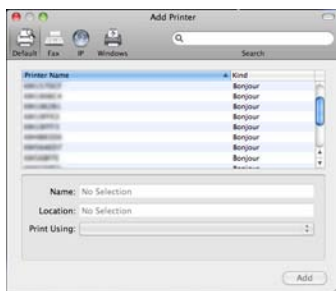

For a Bonjour connection, click the default icon and select the printer for which Bonjour appears in Connection.

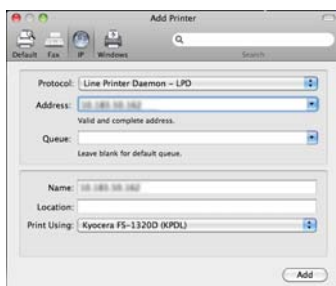

11 Select the installed printer driver and click **Add**.



12 Select the options available for the printer and click **Continue**.



13 The selected printer is added. This completes the printer setup procedure.

Printing

This section explains the printing procedure from an application software. You can specify the printing settings from each tab on KX Driver. KX Driver is stored in the CD-ROM (Product Library). For more information, refer to the *Printer Driver User Guide* in the CD-ROM.

About KX Driver

KX Driver consists of the following tabs.

Quick Print

Use this tab to define basic print options into group profiles that can be accessed quickly and easily.

Basic

Use this tab to select the page size and orientation. The paper source and duplex printing are also selected.

Layout

Use to create multiple pages on a single sheet of paper. Also contains the scaling option.

Imaging

Select this tab to change the print quality, and the font or graphic settings.

Publishing

Use to add covers or page inserts to your output. You can also produce a set of transparencies with a blank or printed sheet interleaved using Transparency Interleaving.

Advanced

Use to set up and add watermarks to your output. This tab incorporates the PRESCRIBE commands into the document.

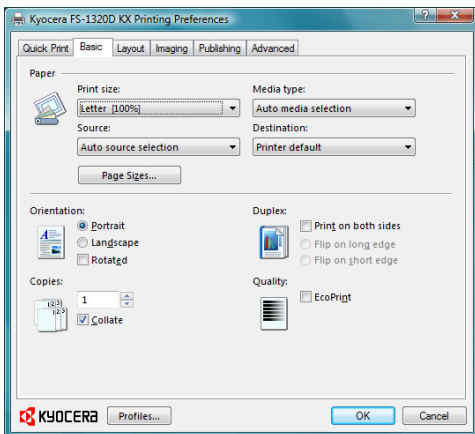

Printing from Application Software

The steps required to print a document created with an application are explained below. You can select the printing paper size.



Note You can also select the various settings by clicking **Properties** to open the Properties dialog box.

- 1** Load the paper required into the paper cassette.
- 2** From the application **File** menu, select **Print**. The Print dialog box appears.
- 3** Click the drop-down list of printer names. All the installed printers are listed. Click the name of the printer.
- 4** Use Number of copies to enter the number of copies required. Up to 999 copies can be printed. For Microsoft Word, we recommend that you click **Options and specify Use printer settings** for the Default tray.
- 5** To start printing, click **OK**.

Status Monitor

The Status Monitor monitors the printer status and provides an ongoing reporting function. It also allows you to specify and modify settings for printers not included in the KX Driver.

The Status Monitor is installed automatically during KX Driver installation.

Accessing the Status Monitor

Use either of the methods listed below to launch the Status Monitor.

- Launch when printing starts:
When you specify a printer and start a print job, one Status Monitor is launched for each printer name. If Status Monitor startup is requested from multiple printers, Status Monitors are launched for each printer that issues the request.
- Launch from the KX Driver properties:
Click **Printing Preferences** in Properties dialog box. Select Advanced tab and click **Status Monitor** to open Status Monitor window. Click **Open Status Monitor** to launch the Status Monitor.

Exiting the Status Monitor

Use either of the methods listed below to exit the Status Monitor.

- Exit manually:
Right-click the Status Monitor icon in the taskbar and select **Exit** in the menu to exit the Status Monitor.
- Exit automatically:
The Status Monitor automatically shuts down after 5 minutes if it is not being used.

Screen Overview

The screen overview of the Status Monitor is as follows.

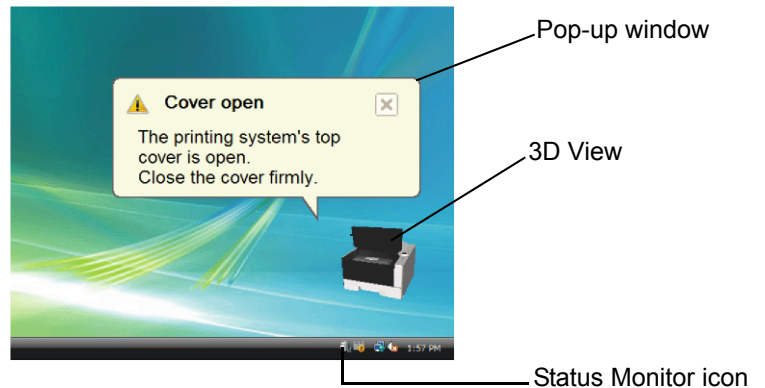

Pop-up window

If an information notification event occurs, a pop-up window appears. This window only appears when the 3D View is open on the desktop.

3D View

This shows the status of the monitored printer as a 3D image. You can choose whether to show or hide the 3D view from the menu displayed when you right-click the Status Monitor icon.

If an information notification event occurs, the 3D view and an alert sound are used to notify you. For information on the sound notification settings, refer to *Status Monitor Settings* on page 3-12.

Status Monitor icon

The Status Monitor icon is displayed in the taskbar notification area when the Status Monitor is running. When you position the cursor over the icon, the printer name appears.

Status Monitor Settings

The Status Monitor has two tabs to configure its settings. Use the **Preference** option to set up the Status Monitor.

Sound Notification Tab

The Event Notification tab contains the following items.

IMPORTANT To confirm the settings on Sound Notification tab, the computer requires the sound capabilities such as sound card and speaker.

Enable Event Notification

Select to enable or disable monitoring the events in Available events.

Sound file

A sound file can be selected if you require an audible notification. Click **Browse** to search for the sound file.

Use Text to speech

Select this check box to enter text you would like to hear played for events. Although a sound file is unnecessary, this function is applicable for Windows XP or later.

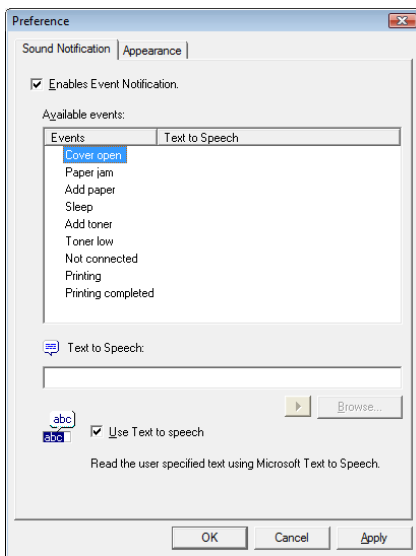

To use this function, follow these steps.

- 1** Select **Enable Event Notification**.
- 2** Select an event to use with the text to speech function in Available events.
- 3** Click Browse to notify the event by sound file.



Note The available file format is WAV.

Select **Use Text to speech** to speech the text entered in Text to speech box when an event occurred.

- 4** Click  to confirm the sound or text is played correctly.

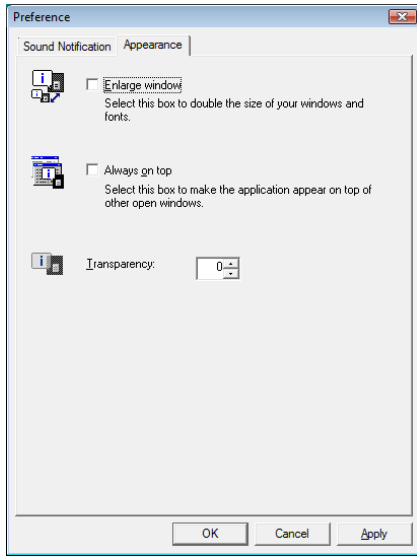

Appearance Tab

The Appearance tab is contains the following items.

Enlarge window

Doubles the size of the Status Monitor window.

Always on top

Positions the Status Monitor in front of other active windows.

Transparency

Displays the Status Monitor as a transparent window.

Configuration Tool

The Configuration Tool allows you to check and/or change the settings for printers not included in the KX Driver.

The Configuration Tool can be used for printers connected to the PC via a USB cable.



Note The contents of the Properties dialog box will vary depending on the installed optional devices, and whether the device is connected by a network interface or a local interface.

Accessing the Configuration Tool

Follow these steps to display the Configuration Tool on the desktop.



Note To configure the settings of the Configuration Tool, run the Status Monitor on your computer at first.

- 1** Right-click the Status Monitor icon in the Windows taskbar.
- 2** Select **Configure the Printing System** from the menu. The Configuration Tool window appears.



Note When the printer is connected with the network cables, COMMAND CENTER starts instead of the Configuration Tool.

Exiting the Configuration Tool

Use either of the methods listed below to exit the Configuration Tool.

- Exit using the Close button:
Click  in the top-right corner of the Configuration Tool window.
- Exit using the OK or Cancel button:
Clicking **OK** exits the Configuration Tool after applying the modified printer settings. Clicking **Cancel** exits the Configuration Tool without applying the modified printer settings.

Status Tab

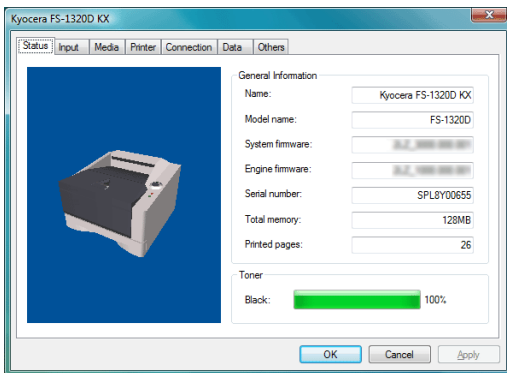

The Status tab displays current information about the device, such as the model name, system firmware, engine firmware, serial number, total memory, and number of printed pages.

Input Tab

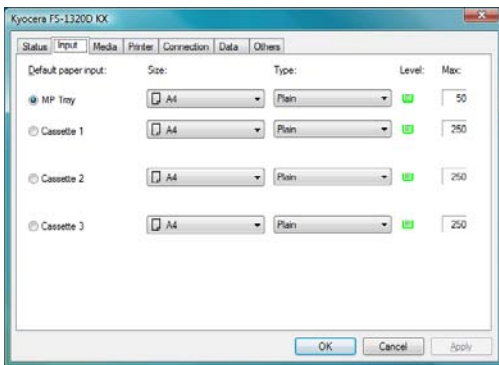

The Input tab displays information about the paper feeder attached to the machine, such as the current paper level and the maximum paper capacity.

Media Tab

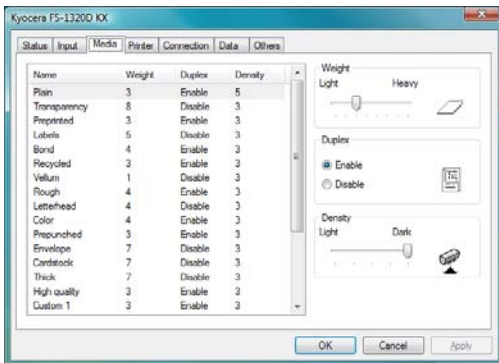

The Media tab displays and lets you select the weight and density for each media type. It also enables or disables duplex printing for the each media type.

Printer Tab

The Printer tab allows you to set print processing parameters that are not available in the KX Driver. As well as the form feed timeout, you can change the memory size used for processing raster data such as bitmap and JPEG files.

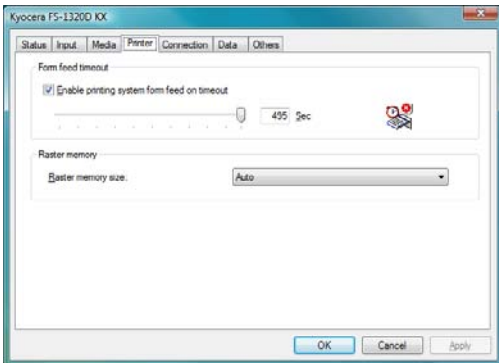

Connection Tab

You can use the Connection tab to set the emulation. You can also use this tab to change the buffer memory size and buffer mode of the printer for communication processing to the host.

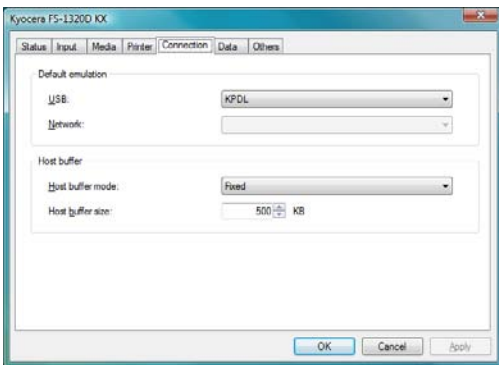

Data Tab

The Data tab fetches and lists the data stored in the CF card or RAM disk. Select a data type and click **View** to fetch and display a list of the target data from the printer. The information displayed includes the name, type and storage location.

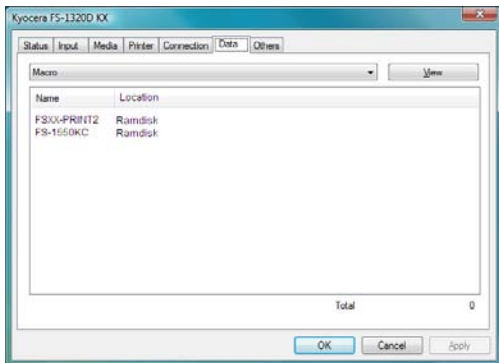

Others Tab

The Others tab enables you to configure the printer settings shown below.

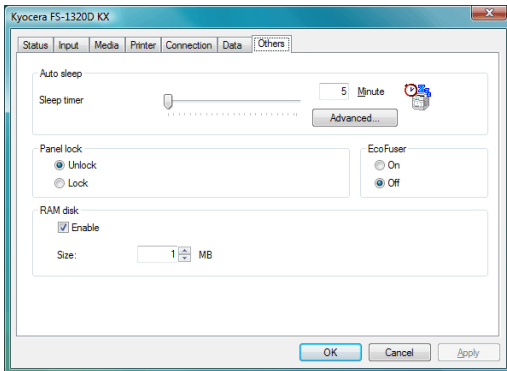

Item	Description
Auto sleep	Configures the amount of time when the printer automatically enters Sleep Mode. Click Advanced to turn Auto sleep On or Off .
EcoFuser	Enables or disables the EcoFuser. Select On to reduce the power consumption to a minimum by turning off the heater of the fixing unit at Sleep Mode. The default setting is On .
Panel lock	Locks or unlocks the operation panel. Locking the operation panel disables key operations from the panel.
RAM disk	Enables or disables RAM disk mode. Enabling the RAM disk allows you to use it as a temporary storage area for data such as font files or the contents of the receive buffer. You can also specify the RAM disk size by clicking Enable .

Uninstalling Software (Windows PC)

The software can be uninstalled (removed) using the CD-ROM (Product Library) supplied with the printer.

IMPORTANT On Macintosh computers, because the printer settings are specified using a PPD (PostScript Printer Description) file, the software cannot be uninstalled using the CD-ROM (Product Library).

- 1** Exit all active software applications.
- 2** Insert the enclosed CD-ROM (Product Library) into the CD-ROM drive. In Windows 7, Windows Server 2008 and Windows Vista, the user account control window may appear. Click **Allow**.
- 3** Following the procedure used to install the printer driver, click **Remove Software**. The Kyocera Uninstaller wizard appears.
- 4** Select the software package to remove.
- 5** Click Uninstall.



Note When KMnet Viewer is installed, separate uninstallers are launched for this application. Proceed with the uninstallation steps for this application as directed by the on-screen instructions.

The uninstaller starts.

- 6** When Uninstall complete screen appears, click **Finish**.
- 7** If Restart Your System screen appears, select whether you restart your computer or not, and click **Finish**.



Note The software can be uninstalled from the Program menu.

Start the uninstaller by clicking **start > All Programs > Kyocera > Uninstall Kyocera Product Library**, and uninstall the software.

4 Maintenance

This chapter explains how to replace the toner container and clean the printer.

General Information	4-2
Toner Container Replacement	4-2
Maintenance Kit Replacement	4-5
Cleaning the Printer	4-6
Prolonged Non-Use and Moving of the Printer	4-9

General Information

This chapter describes basic maintenance tasks you can perform for the printer. You can replace the toner container according to the printer's status:

Also, the internal parts need periodic cleaning.



Note Information Collection on Memory Chips - The memory chip attached to the toner container is designed to improve convenience for the end user; to support the recycling operation of empty toner containers; and to gather information to support new product planning and development. The information gathered is anonymous - it cannot be associated to any specific individual and the data is intended to be used anonymously.

Toner Container Replacement

The Toner indicator identifies the toner status at two stages of toner usage.

- When the printer becomes low on toner, the **Toner** indicator flashes. Note the replacement is not always necessary at this stage.
- If you ignore the above status and continue printing, the **Toner** indicator lights up just before the toner is used up. The toner container must then be replaced immediately.

In either case, replace the toner container.

Frequency of toner container replacement

Assuming an average toner coverage of 5% and EcoPrint mode turned off, the toner container will need replacing approximately once every 7,200 pages (FS-1320D) or 2,500 pages (FS-1120D).

Starter Toner Container

The toner container packed with the new printer is a starter toner container. The starter toner container lasts an average of 2,300 pages (FS-1320D) or 1,000 pages (FS-1120D).

Toner Kits

For best results, we recommend that you only use genuine Kyocera Parts and Supplies.

A new toner kit contains the following items:

- Toner Container
- Plastic waste bag for old toner container
- Installation Guide



Note Do not remove the toner container from the carton until you are ready to install it in the printer.

Replacing the Toner Container

This section explains how to replace the toner container.



CAUTION Do not attempt to incinerate the Toner Container. Dangerous sparks may cause burns.

IMPORTANT During toner container replacement, temporarily move storage media and computer supplies (such as floppy disks) away from the toner container. This is to avoid damaging media by the magnetism of toner.

IMPORTANT Kyocera Mita Corporation is not liable against any damages or problems arising from the use of toner containers other than those designated as original Kyocera toner containers. For optimum performance, it is also recommended to use only the Kyocera toner containers which are specifically intended for use in your country or region. If the toner container for another destinations is installed, the printer will stop printing.



Note You do not have to turn printer power off before starting the replacement. Any data that may be processing in the printer will be deleted if you turn the printer power off.

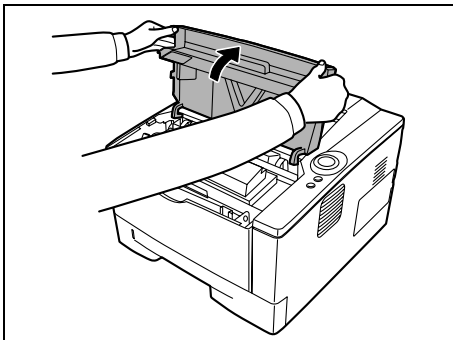

1 Open the top cover.

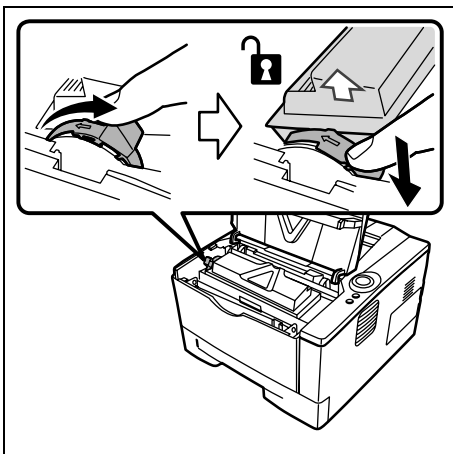

2 Turn the lock lever to the unlock position. Push the lock lever to the position marked by the arrow and pull out the toner container.



Note Put the old toner container in the plastic bag (supplied with the new toner kit) and discard it later according to the local code or regulations for waste disposal.

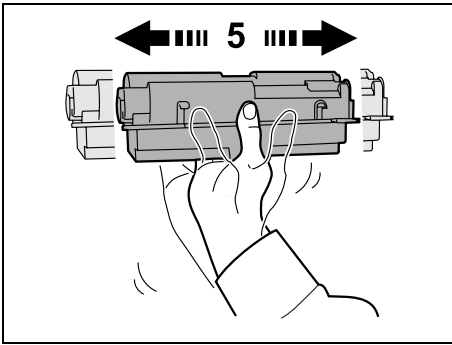

- 3** Take the new toner container out of the toner kit. Shake the new toner container at least 5 times as shown in the figure in order to distribute the toner evenly inside the container.

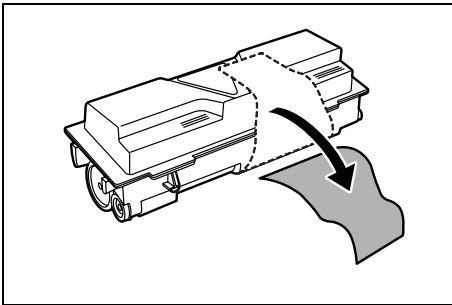

- 4** Remove the label from the toner container.

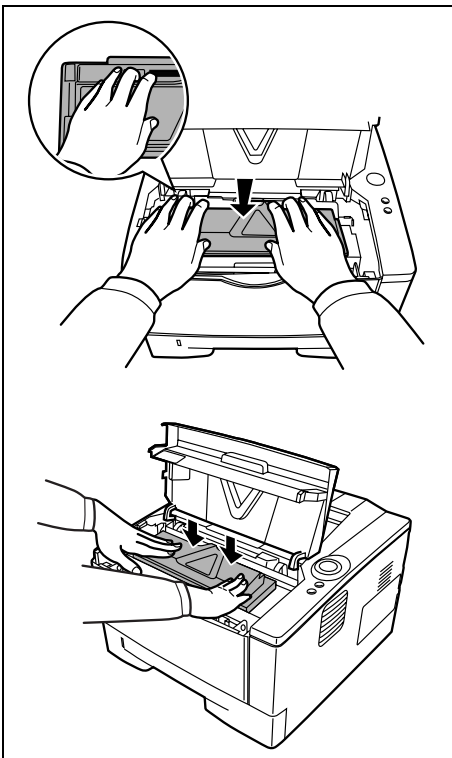

- 5** Install the new toner container in the printer. Push firmly on the top of the container at the positions marked PUSH, until you hear a click.

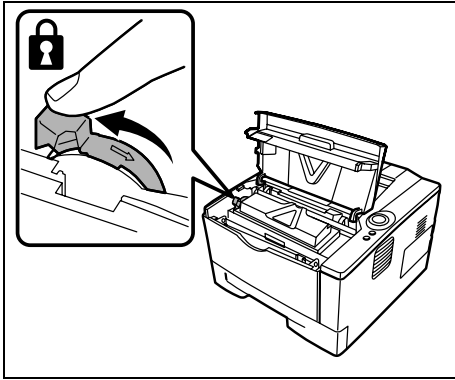

- 6** Turn the lock lever to the lock position.
- 7** Close the top cover.

Maintenance Kit Replacement

When the machine prints 100,000 pages, a message is printed indicating that the maintenance kit should be replaced. The maintenance kit must then be replaced immediately.

To replace the maintenance kit, contact your service technician.

IMPORTANT When the waste toner in the drum unit is almost full, **[Attention]** indicator and **[Toner]** indicator are flashing. Replace the maintenance kit.

Cleaning the Printer

To avoid print quality problems, the interior of the printer must be cleaned with every toner container replacement.

- 1 Open the top cover and front cover.

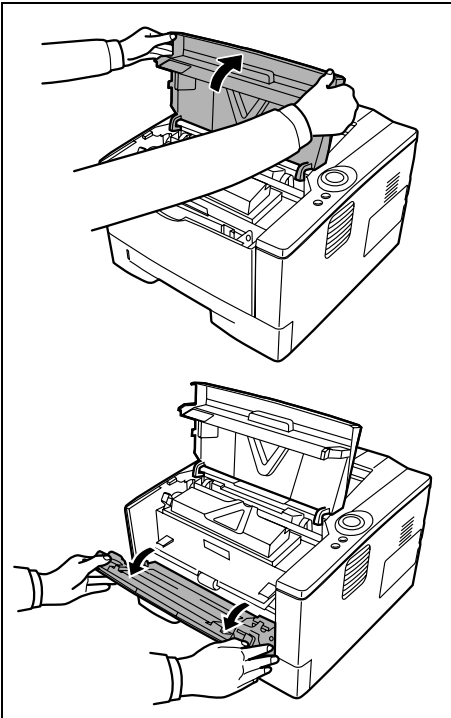

- 2 Lift the developer unit together with the toner container out of the printer.

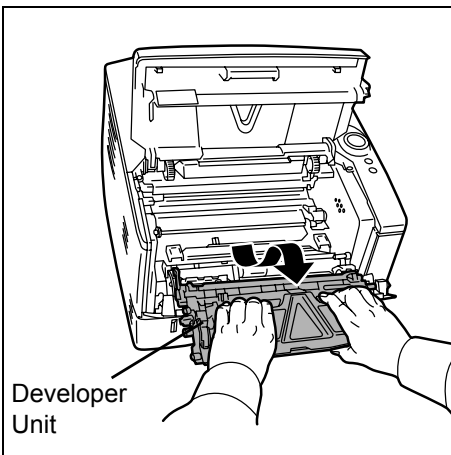

- 3 Remove the drum unit from the printer by holding the green levers with both hands.



Note The drum unit is sensitive to light. Never expose the drum unit to light for more than five minutes.

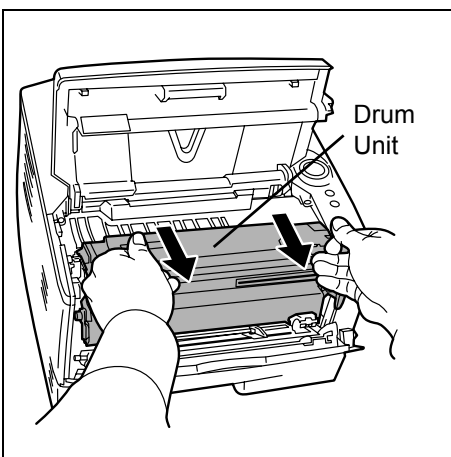

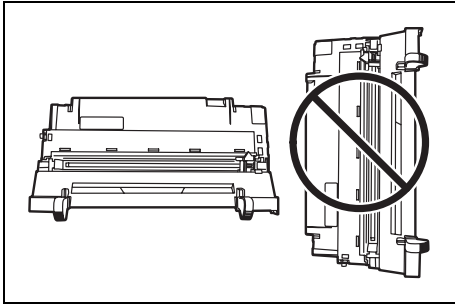

- 4** Place the drum unit flat on a clean, level surface.
IMPORTANT Do not place the drum unit on end.

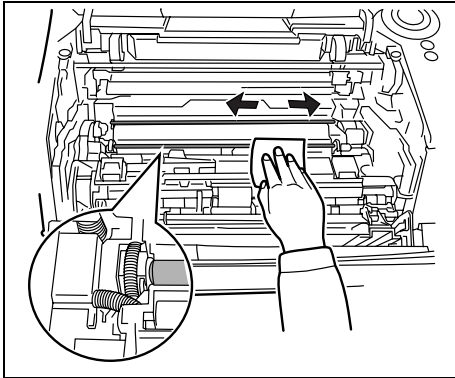

- 5** Use a clean, lint free cloth to clean dust and dirt away from the metal registration roller.
IMPORTANT Take care not to touch the transfer roller (black) during cleaning.

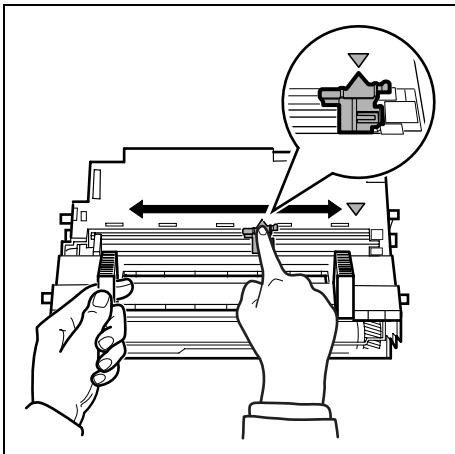

- 6** On the drum unit, slide the charger cleaner (green) back and forth 2 or 3 times to clean the charger wire, then return it to its original position (CLEANER HOME POSITION).
IMPORTANT Remove the fixing tape on the charger cleaner before cleaning for the first time.

After cleaning, make sure you restore the charger cleaner to its home position.

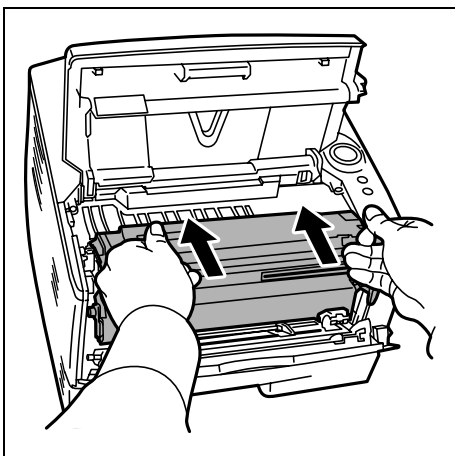

- 7** When cleaning is complete, return the drum unit to the original position.

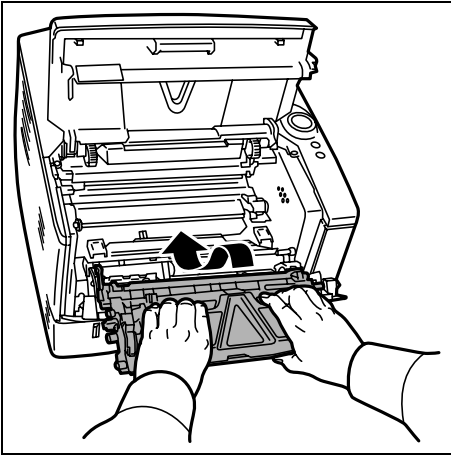

- 8** Return the developer unit to its position, aligning the guides at both ends with the slots in the printer. Then, close the front cover and top cover.

Prolonged Non-Use and Moving of the Printer

Prolonged Non-use

If you ever leave the printer unused for a long period of time, remove the power cord from the wall outlet.

We recommend you consult with your dealer about the additional actions you should take to avoid possible damage that may occur when the printer is used next time.

Moving the Printer

When you move the printer:

- Move it gently.
- Keep it as level as possible to avoid spilling toner inside the printer.
- Be sure to consult a service technician before attempting longdistance transportation of the printer.



WARNING If you ship the printer, remove and pack the developer unit and drum unit in a plastic bag and ship them separately from the printer.

5 Troubleshooting

This chapter explains how to handle printer problems, understand indicator combinations, and clean paper jams.

General Guidelines	5-2
Print Quality Problems	5-3
Understanding Indicators	5-5
Cleaning Paper Jams	5-11

General Guidelines

The table below provides basic solutions for problems you may encounter with the printer. We suggest you consult this table to troubleshoot the problems before calling for service repairs.

Symptom	Check Items	Corrective Actions
The printer will not print from the computer.	Check the Ready indicator.	Using the information on page 1-5, check if an error has occurred and clear the error.
	Check if a status page can be printed.	If the status page was printed successfully, there may be a problem with the connection to the computer. Refer to the <i>Installation Guide</i> and check the connection.
	Check that the indicators display in a recognized combination. Refer to <i>Indicators</i> on page 1-5 for further information.	Turn the power switch Off (O) and then On () again. Print the job again.
Print quality is poor.	–	Select half speed mode using the printer driver. Refer to <i>Print Quality Problems</i> on page 5-3.
	–	This is a problem specific to the Windows OS. It is not a printer problem. It does not affect print quality.
Text is missing on the Windows test page.	–	Refer to <i>Cleaning Paper Jams</i> on page 5-11.
Paper is jammed.	–	Connect both ends of the power cord securely. Try replacing the power cord. Refer to <i>Installation Guide</i> for information.
The indicators are off and the fan is not working.	Check the power cord.	Refer to the <i>Installation Guide</i> for more information.
	Check the power switch is in the On () position.	
The printer prints a status page but data from the computer is not being printed.	Check program files and application software.	Try printing another file or using another print command. If the problem occurs with a specific file or application, check the printer settings for that application.
	Check the interface cable.	Connect both ends of the interface cable securely. Try replacing the printer cable. Refer to the <i>Installation Guide</i> for more information.
Vapor is emitted near the top tray.	Check if the temperature is low near the location of the printer, or if the paper that is being used has been exposed to humidity.	Depending on the operating environment of the printer and the condition of the paper, heat generated during printing can evaporate water moisture in the printed paper, emitting vapor from the printer. In this case, printing can be continued without any problem. To correct this, increase the temperature in the room, and use paper that has been stored in a dry place.

Tips

Printer problems may be solved easily by following the tips below. When you have encountered a problem that cannot be solved following the guidelines above, try the following:

- Restart the computer you are using to send print jobs to the printer.
- Obtain and use the latest version of the printer driver. The latest versions of printer drivers and utilities are available at: <http://www.kyoceramita.com/download/>.
- Make sure that the procedures for printing are correctly followed in the application software. Consult the documentation supplied with the application software.

Print Quality Problems

The tables and diagrams in the following sections define print quality problems and the corrective action you can conduct to solve the problems. Some solutions may require cleaning or replacing parts of the printer.

If the suggested corrective action will not solve the problem, call for service.

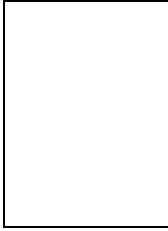
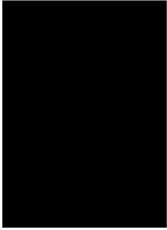
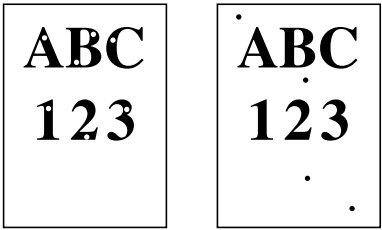
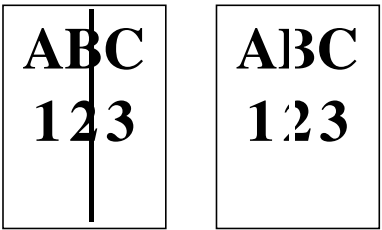
Printed Results	Corrective Action
<p>Completely blank printout</p> 	<p>Check the toner container. Open the <i>front cover</i> and check that the toner container is correctly installed in the printer. Refer to <i>Toner Container Replacement</i> on page 4-2.</p>
<p>Full single-color printout</p> 	<p>Contact your service technician.</p>
<p>Dropouts, stray dots</p> 	<p>Drum or developer unit may be damaged. If the problem is not solved even after printing several pages, call for service.</p>
<p>Vertical streaks</p> 	<p>Check the toner container and if necessary replace. Refer to <i>Toner Container Replacement</i> on page 4-2.</p> <p>Clean the charger wire. Refer to <i>Cleaning the Printer</i> on page 4-6.</p> <p>Check the charger cleaner of the drum unit is in its original position. Refer to <i>Cleaning the Printer</i> on page 4-6.</p>

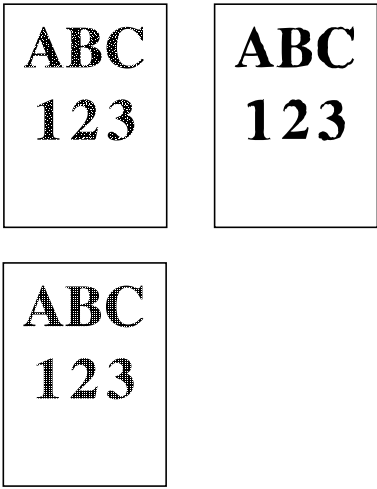
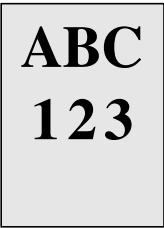
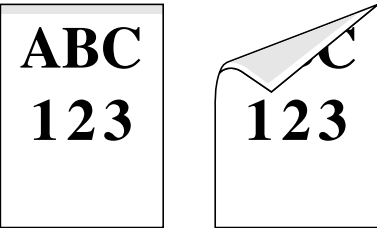
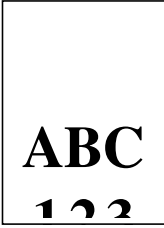
Printed Results	Corrective Action
<p>Faint or blurred printing</p> 	<p>Check the toner container and if necessary replace. Refer to <i>Toner Container Replacement</i> on page 4-2.</p> <p>Clean the charger wire. Refer to <i>Cleaning the Printer</i> on page 4-6.</p>
<p>Gray background</p> 	<p>Check the toner container and if necessary replace. Refer to <i>Toner Container Replacement</i> on page 4-2.</p> <p>Check the developer unit and drum unit are installed correctly. Refer to <i>Cleaning the Printer</i> on page 4-6.</p>
<p>Dirt on the top edge or back of the paper</p> 	<p>If the problem is not solved even after printing several pages, clean the registration roller. Refer to <i>Cleaning the Printer</i> on page 4-6.</p> <p>If the problem is not solved after cleaning, call for service.</p>
<p>Printing incomplete or out of position</p> 	<p>Check that the printing settings are correct in the application software and the printer driver.</p> <p>Check whether the problem is being caused by a PRESCRIBE command error. If the problem occurs only with a specific file or program, the most likely cause is an error in a parameter to a command or command syntax.</p>

Understanding Indicators

The *indicator* displays generally fall into one of three categories: normal operation, maintenance and errors (repairs).



Click the icon  to play the animation of the indicator combinations. Right-click an indicator, then select **Playback** and **Play** to play the animation repeatedly.

IMPORTANT To play the animation, you have to install Adobe Flash Player and Adobe Reader (Version 6.01 or more) to your PC. If the animation is not displayed, you should get the latest version from Adobe site (<http://www.adobe.com/downloads/>).

Normal Indication

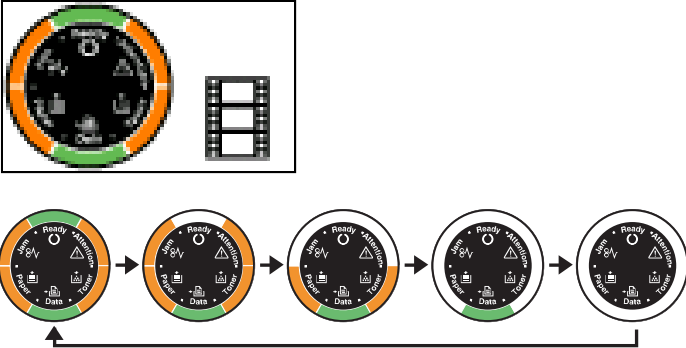
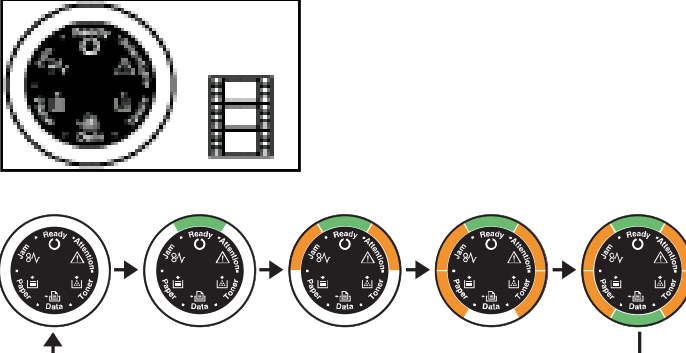
The table below shows the indicator combinations when the printer status is normal.

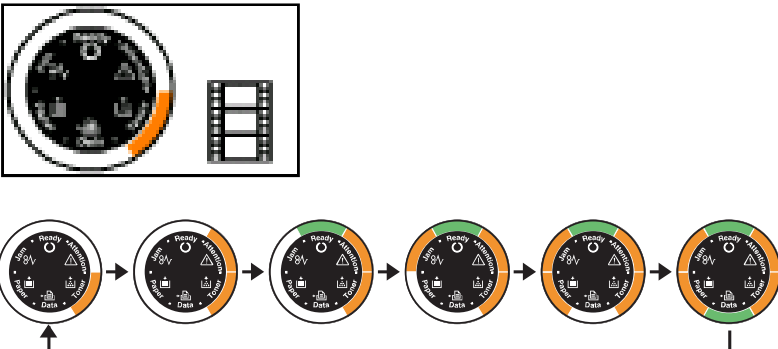
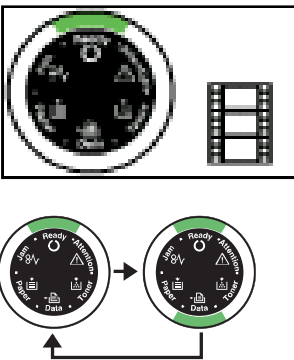

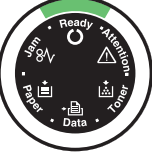
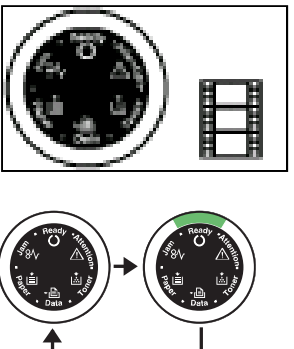
Indicator	Meaning
	<p>The printer is canceling data.</p>
	<p>The printer is warning up. The printer is adjusting the color.</p>

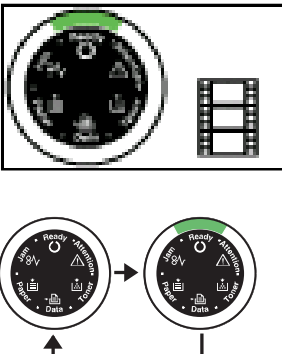

Indicator	Meaning
	<p>The printer is installing toner.</p>
	<p>The printer is receiving data.</p>
	<p>The printer is receiving data. Printing resumes when the [GO] is pressed. The printer is printing the last page after waiting.</p>
	<p>Printing is possible.</p>
	<p>Offline status. You cannot print, but the printer can receive data. The printer returns to online status when the [GO] is pressed.</p>

Indicator	Meaning
 <p data-bbox="539 539 938 568">[Ready] indicator is flashing slowly.</p>	<p data-bbox="1093 297 1500 454">The printer is in sleep mode. The printer returns to online status when the [GO] is pressed, the cover is opened and closed, or the printer receives the print jobs.</p>

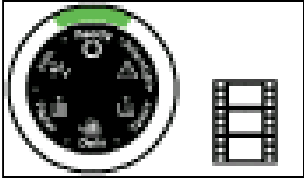
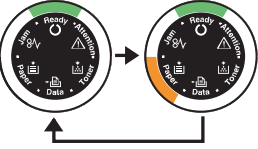
Maintenance Indication

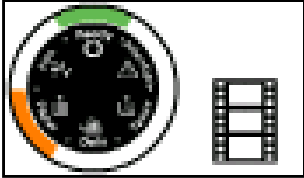
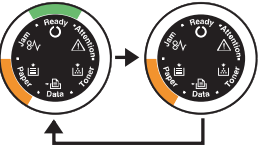
The table below shows the indicator combinations when user intervention is required. It is assumed that the printer is online and is processing data.

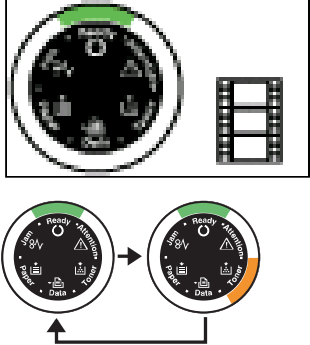
Indicator	Meaning	Remedy
 	There is no paper in the cassette, MP tray.	Load paper into the paper source.
	The cassette is not inserted properly.	Insert the cassette fully into the printer.
	The top cover is open.	Close the cover.
	There is no cassette in the paper feeder or the cassette specified as a paper supply is not inserted properly.	Re-insert the cassette and then try printing again.
	The developer unit or toner container is not installed.	Install the developer unit or toner container.
 	The cassette does not contain the paper specified by the printer driver.	Load the paper into the cassette (#[1 or 2]) and then restart printing. You can change the paper source by pressing the [GO] .
	The paper sizes do not match.	If the paper size in the paper source differs from the paper size and type specified by the printer driver, you can print by supplying paper from the MP tray. Load the correct paper size and type into the MP tray and press [GO] to begin printing.
		If you want to supply paper from a source other than the MP tray, you can change the paper source by pressing [GO] .
	If the paper fed from the MP tray is a different size from the specified paper size, a paper jam will occur.	

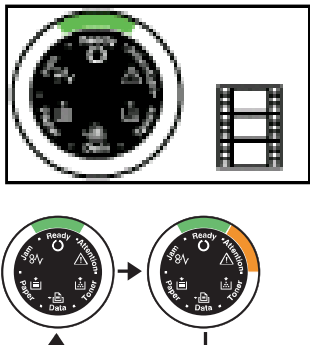
Indicator	Meaning	Remedy
	<p>A paper jam occurred during printing.</p>	<p>Open the printer cover and remove the jammed paper.</p>
	<p>The toner is running low.</p>	<p>Have a new toner container ready.</p>
	<p>The toner has run out.</p>	<p>Replace with a new toner container. After replacing the toner container, clean the inside of the printer.</p>
	<p>The installed toner container's regional specification does not match the printer's.</p>	<p>Install the specified toner container.</p>
	<p>Unable to print with the specified resolution due to insufficient memory.</p>	<p>Add the expansion memory to the printer.</p>
	<p>CF card is not formatted.</p>	<p>Format the CF card.</p>

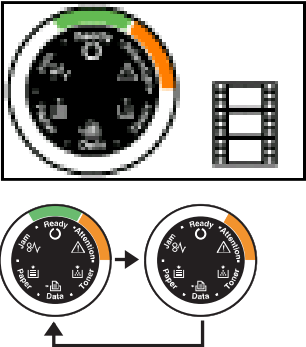
Indicator	Meaning	Remedy
	Specified file not found.	Press [GO] to continue processing. Press [Cancel] to cancel processing.
	The current printing cannot be continued.	Press [GO] to continue processing. Press [Cancel] to cancel processing.
	Unable to print due to insufficient memory.	Install the expansion memory in the printer. Press [GO] to continue processing. Press [Cancel] to cancel processing.
	Unable to print as the data is too complicated.	Press [GO] to continue processing. Press [Cancel] to cancel processing.

Error Indication

If the indicators light or flash repeatedly in manners not described above for normal or maintenance indication, a service error has probably occurred. Turn the printer off by the power switch, wait 5 seconds and then turn the printer on again. This may clear the error. Even if the error is not cleared, contact your service technician.

Cleaning Paper Jams

If paper jams in the paper transport system, or no paper sheets are fed at all, the printer automatically goes offline, and the **Jam** indicator will light. Status Monitor or COMMAND CENTER can indicate the location of the paper jam (the component where the paper jam has occurred). Remove the paper jam. After removing the paper jam, the printer will resume printing.

Possible Paper Jam Locations

The figure below shows the printer's paper paths including the optional paper feeder. The locations where paper jams might occur are also shown here, with each location explained in the table below. Paper jams can occur in more than one component on the paper paths.

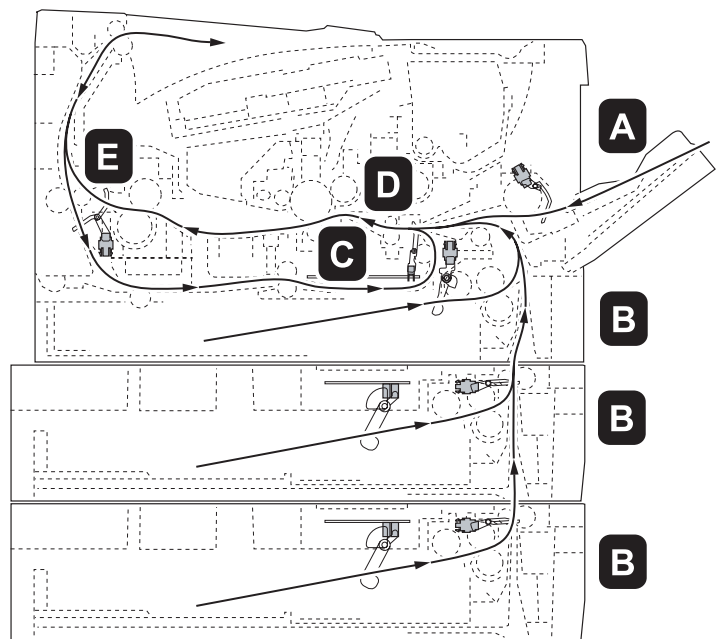

Paper jam location	Description	Reference page
A	Paper jam at the MP tray.	<i>page 5-12</i>
B	Paper jam at the paper cassettes. The cassette number can be 1.	<i>page 5-13</i>
C	Paper jam inside the duplexer.	<i>page 5-14</i>
D	Paper jam inside the printer.	<i>page 5-15</i>
E	Paper jam at the rear cover.	<i>page 5-17</i>

General Considerations for Clearing Jams

Bear in mind the following considerations when attempting paper jam removal:



CAUTION When pulling the paper, pull it gently so as not to tear it. Torn pieces of paper are difficult to remove and may be easily overlooked, deterring the paper jam recovery.

- If paper jams occur frequently, try using a different type of paper, replace the paper with paper from another ream, or flip the paper stack over. The printer may have problems if paper jams recur after the paper is replaced.
- Whether or not the jammed pages are reproduced normally after printing is resumed, depends on the location of the paper jam.

MP Tray

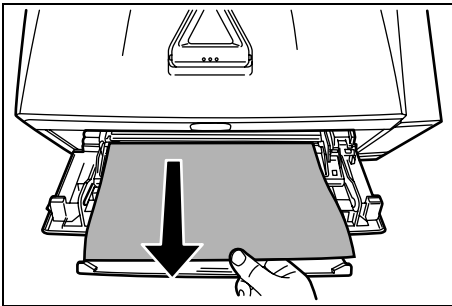

- 1** Remove the paper jammed at the MP tray.

IMPORTANT Do not try to remove paper that has already been partially fed. Proceed to *Inside the Printer* on page 5-15.

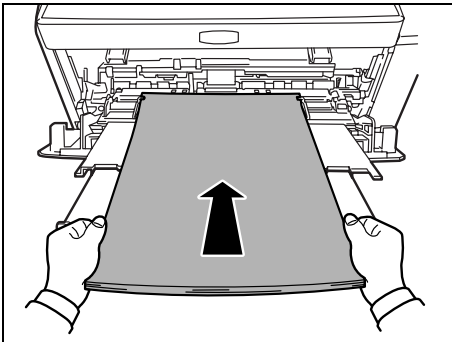

- 2** Reload the MP tray. Open and close the top cover to clear the error and the printer warms up and resumes printing.

Paper Cassette/Paper Feeder

- 1 Pull out the cassette or optional paper feeder.
- 2 Remove any partially fed paper.

IMPORTANT Do not try to remove paper that has already been partially fed. Proceed to *Inside the Printer* on page 5-15.



Note Check to see if paper is loaded correctly. If not, reload the paper.

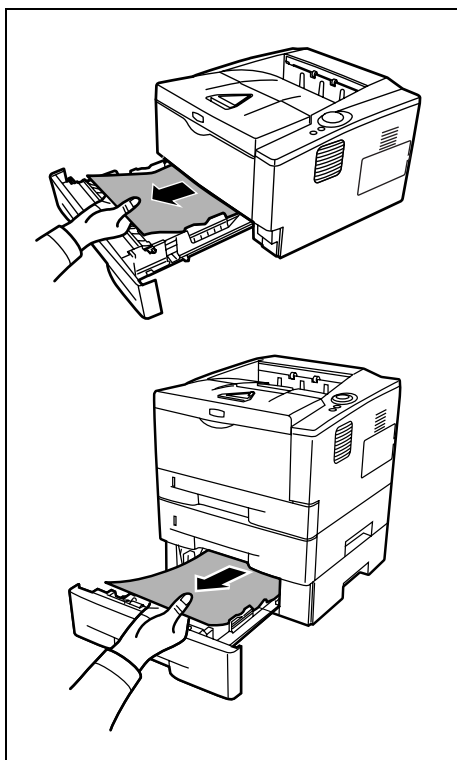

- 3 Push the cassette back in securely. The printer warms up and resumes printing.

Duplexer

Paper is jammed in the duplexer. Remove the jammed paper using the procedure given below.

- 1** Pull the paper cassette all the way out of the printer.
- 2** Open the duplexer's cover in front of the printer and remove any jammed paper.

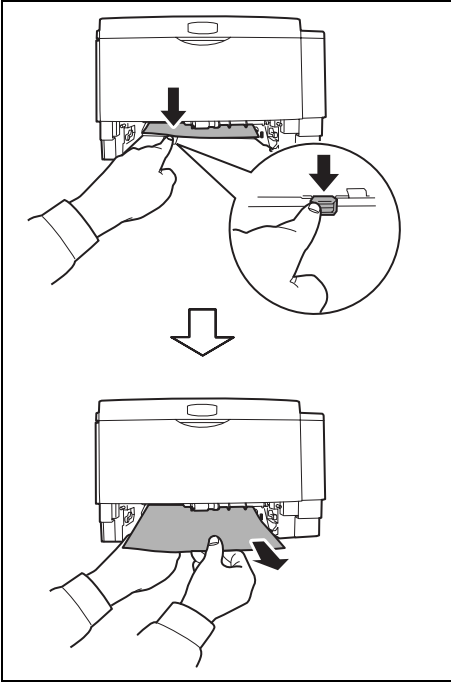

Open the duplexer's cover at the rear of the printer and remove any jammed paper.

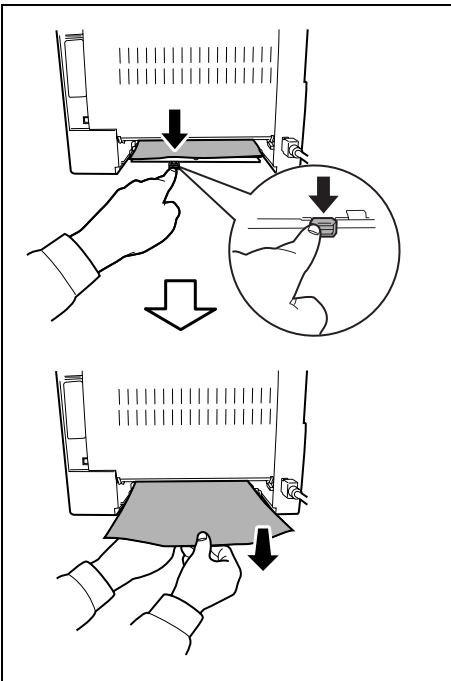

- 3** Push the cassette back in securely, and open and close the top cover to clear the error. The printer warms up and resumes printing.

Inside the Printer

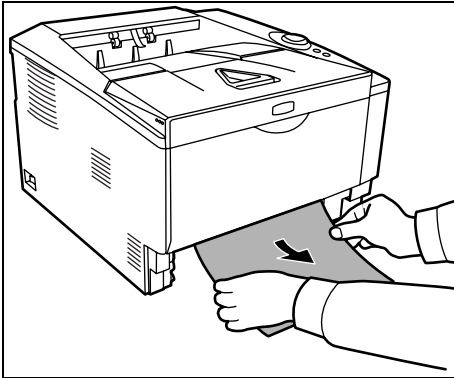

- 1 Pull the paper cassette all the way out of the printer. Remove any partially fed paper.

IMPORTANT Do not try to remove paper that has already been partially fed. Proceed to step 2.

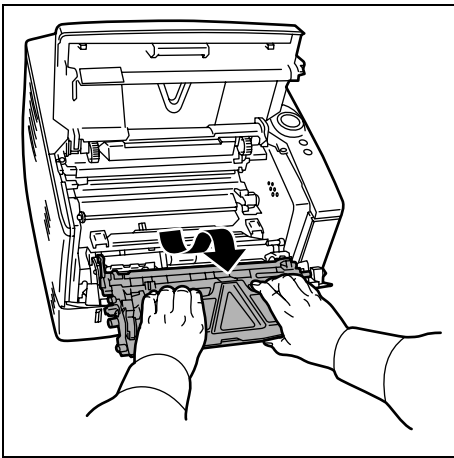

- 2 Open the top cover and front cover, and lift the developer unit together with the toner container out of the printer.

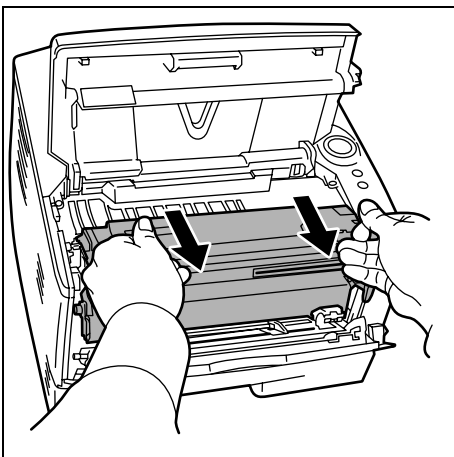

- 3 Remove the drum unit from the printer by holding the green levers with both hands.



CAUTION The fuser unit inside the printer is hot. Do not touch it, as it may result in burn injury.



Note The drum is sensitive to light. Never expose the developer unit to light for more than five minutes.

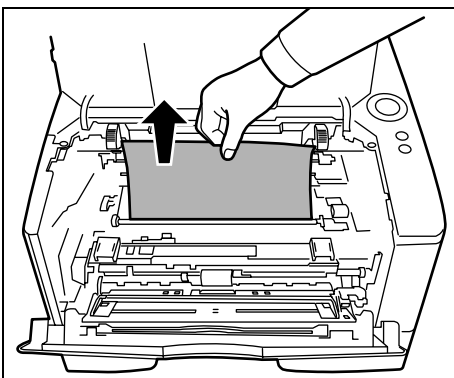

- 4 If the jammed paper appears to be pinched by rollers, pull it along the normal running direction of the paper.

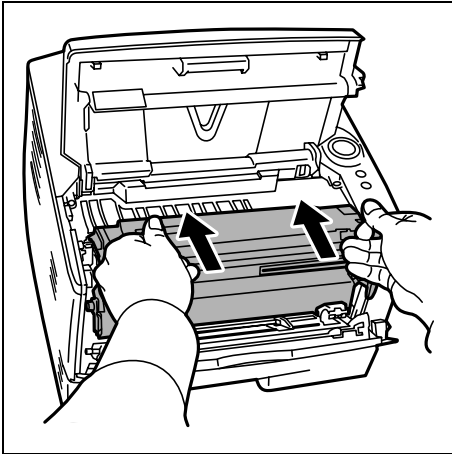

- 5** Return the drum unit to its position, aligning the guides at both ends with the slots in the printer.

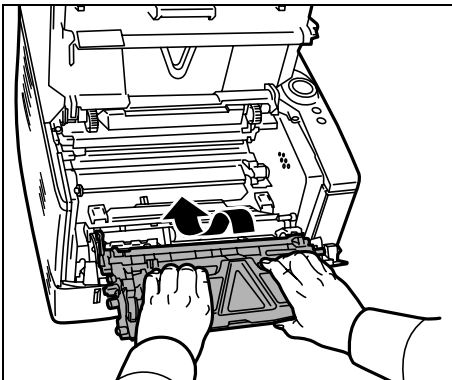

- 6** Insert the developer unit together with the toner container, back into the machine. Close the top cover and the front cover. The printer warms up and resumes printing.

Rear Cover

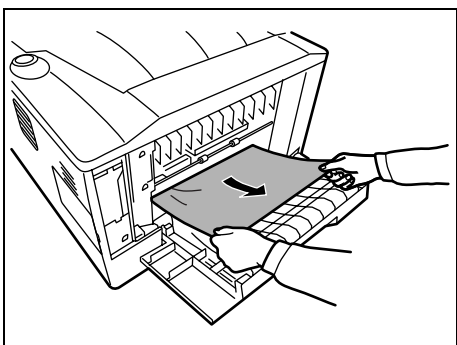

- 1 Open the rear cover and remove the jammed paper by pulling it out.



CAUTION The fuser unit inside the printer is hot. Do not touch it, as it may result in burn injury.

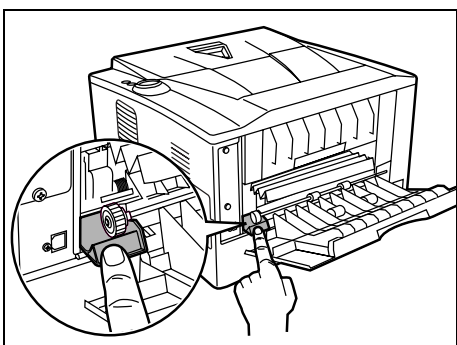

If the paper is jammed inside the fuser unit, open the fuser cover and remove the paper by pulling it out.

- 2 Close the rear cover, and open and close the top cover to clear the error. The printer warms up and resumes printing.

6 Option

This chapter explains the options for this printer.

General Information	6-2
Expansion Memory Modules	6-3
Removing a Memory Module	6-5
Verifying the expanded memory	6-5
Paper Feeder (PF-100)	6-6
Network Interface Card (IB-23)	6-7
CompactFlash (CF) Card	6-8

General Information

The printers have the following options available to satisfy your printing requirements.

 **Note** Install the memory module before installing the optional paper feeder (PF-100).

For instructions on installing individual options, refer to the documentation included with the option. Some options are explained in the following sections.

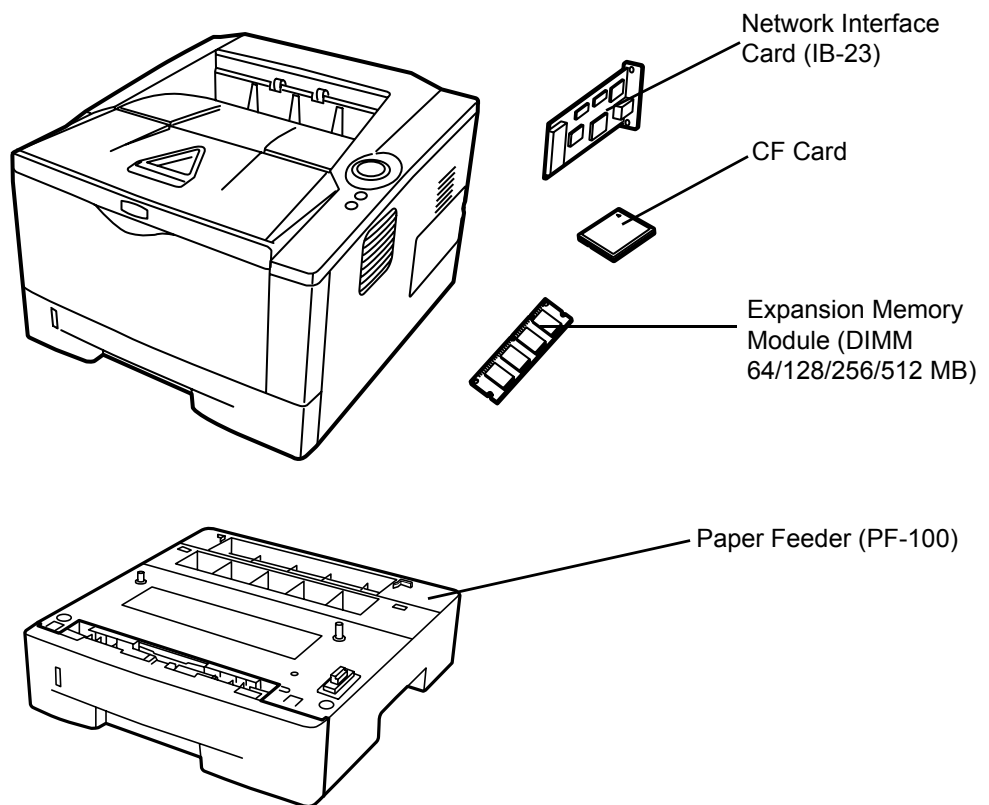

Expansion Memory Modules

To expand the printer memory for more complex print jobs and faster print speed, you can plug in optional memory module (dual in line memory module) in the memory slot provided on the printer main controller board. You can select additional memory module from 64, 128, 256 or 512MB. The maximum memory size is 544MB.



Note The expansion memory should only be installed by your service technician. We shall not be liable for any damages caused by improper installation of expansion memory.

Precautions for handling the printer's main controller board and memory module

To protect electronic parts, discharge static electricity from your body by touching a water pipe (faucet) or other large metal object before handling the memory module. Or, wear an antistatic wrist strap, if possible, when you install the memory module.

Always hold the main controller board or a memory module by its edges as shown below to avoid damaging electronic parts.

Correct

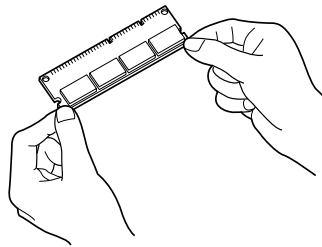

Incorrect

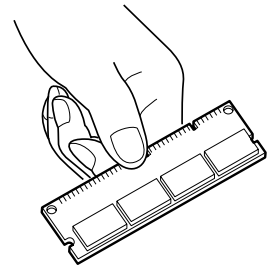

Installing the Memory Module

- 1 Turn off the printer and disconnect the power cord and printer cable.
- 2 Remove the right cover as shown in the figure.

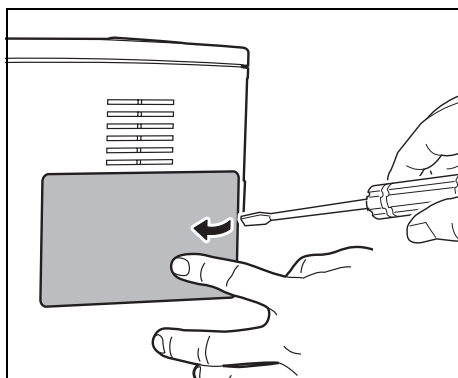

- 3 Remove the fixing tape in case of the first installation. Then, remove the memory slot cover as shown in the figure.

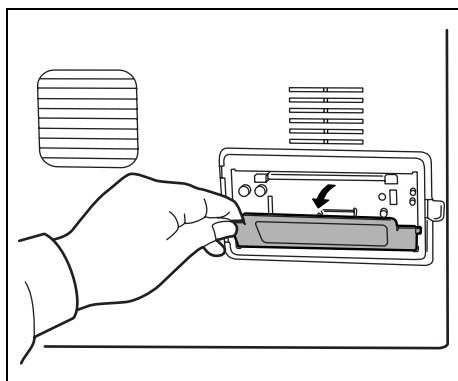

- 4 Push out the clamps on both ends of the memory socket.
- 5 Remove the memory module from its package.

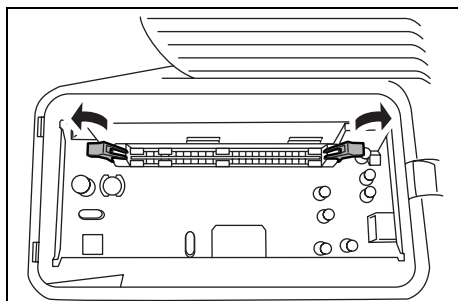

- 6 Aligning the cutouts of the memory module with the matching keys of the socket, carefully plug the memory module into the memory socket until it clicks in place.

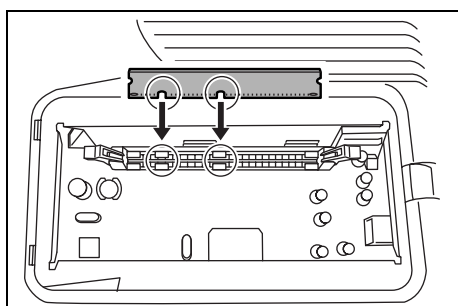

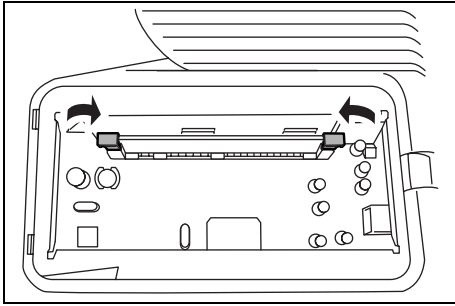

7 The memory module is secured to the memory socket with the clamps.

8 Reinstall the memory slot cover and the right cover.

Removing a Memory Module

To remove a memory module, remove the right cover and the memory slot cover from the printer. Then, carefully push out the two socket clamps. Ease the memory module out of the socket to remove.

Verifying the expanded memory

To verify that the memory module is working properly, test it by printing a status page.

Paper Feeder (PF-100)

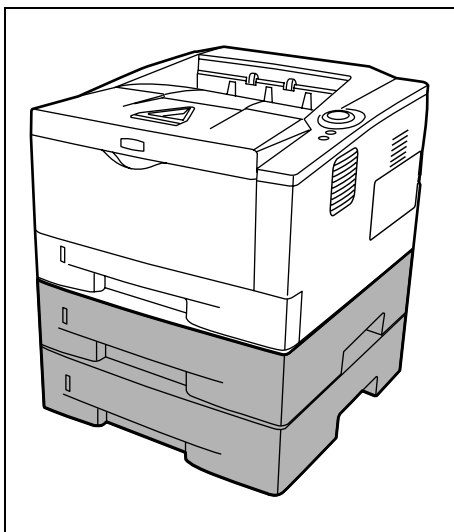

The PF-100 allows you to add one (for FS-1120D) or two (for FS-1320D) more paper cassette to the bottom of the printer for continuous feeding of a large volume of paper. Each paper cassette can hold up to approximately 250 sheets of ISO A4, ISO A5, JIS B5, Letter, or Legal size (80g/m²) paper. This feeder is attached at the bottom of the printer as shown on the left.

Network Interface Card (IB-23)

The network interface card supports TCP/IP, IPX/SPX, NetBEUI and AppleTalk protocols, so that the printer can be used on network environments including Windows, Macintosh, UNIX, NetWare, etc.

The network interface card must be installed in the option interface slot that is located at the back of the printer.



CAUTION Before inserting a network interface card in the printer, make sure that the printer is switched off.

- 1 Turn off the printer and disconnect the power cord and printer cable.
- 2 Open the rear cover.

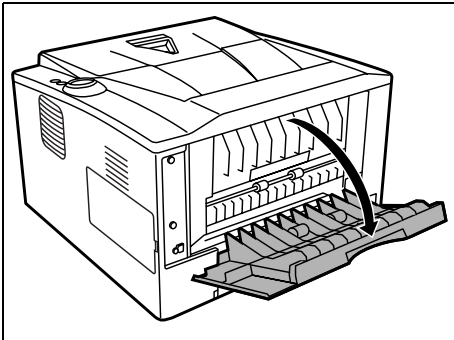

- 3 Remove the optional interface slot cover.

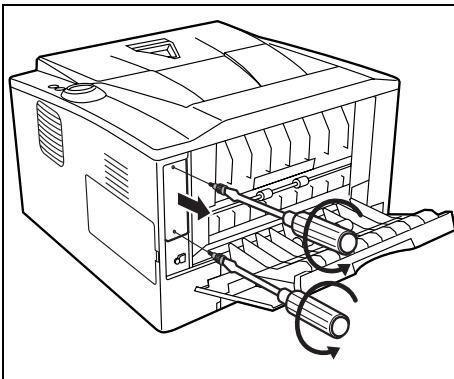

- 4 Insert the Network Interface Card and secure it with the screws removed in step 3.

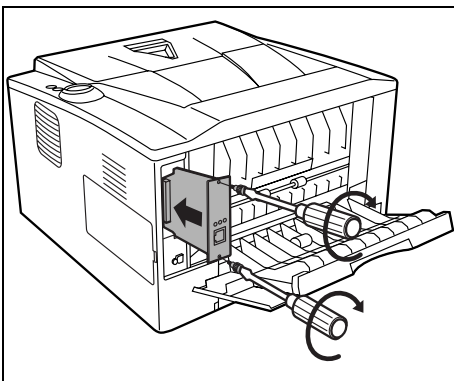

- 5 Close the rear cover, and connect the printer cable.
- 6 Connect the power cord, and turn on the printer.
- 7 Configure the network address from Quick Setup. For more information, refer to *Operation Guide* of the network card.

CompactFlash (CF) Card

To read the optional fonts, macros, and overlays stored in the CF card, insert the CF card to the slot of the printer according to the following steps.

The maximum size of the CF card is 256MB. For details of the CF card, contact your service technician.

- 1 Turn off the printer and disconnect the power cord and printer cable.



CAUTION Before inserting a CF card in the printer, make sure that the printer is switched off.

- 2 Open the rear cover.

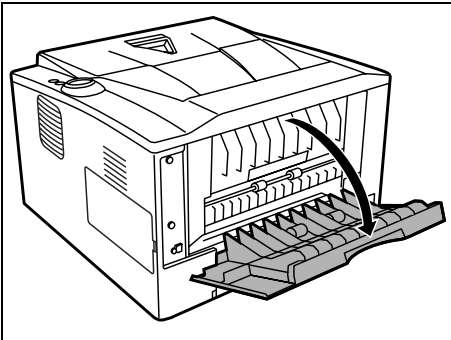

- 3 Remove the optional interface slot cover.

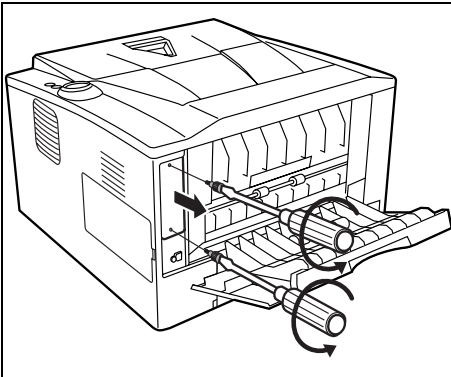

When the Network Interface Card is installed, remove it.

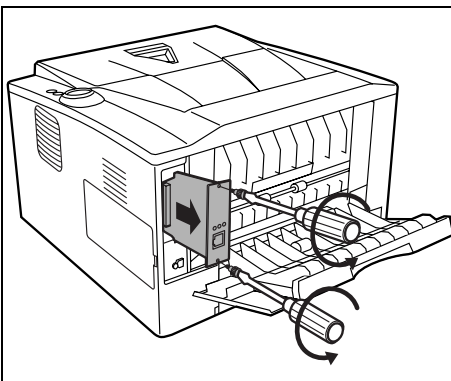

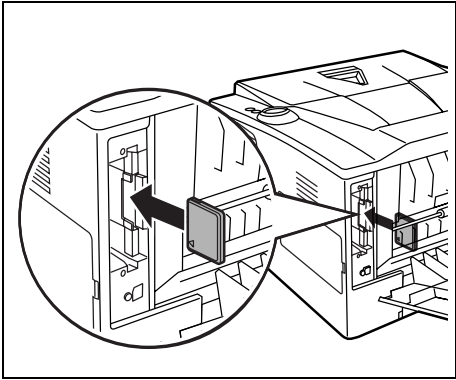

4 Insert the CF Card.

5 Secure it with the screws removed in step 3.

6 Connect the power cord and printer cable and turn on the printer.

7 Appendix

This section lists the following information of this printer.

Specifications	7-2
Environmental Standard Requirements	7-4

Specifications



Note These specifications are subject to change without notice.

Item	Description		
	FS-1120D	FS-1320D	
Type	Desktop		
Printing Method	Electrophotography, laser scan		
Paper Weight	Cassette	60 to 120 g/m ² (Duplex: 60 to 105 g/m ²)	
	MP Tray	60 to 220 g/m ²	
Paper Type	Cassette	Plain, Preprinted, Bond, Recycled, Rough, Letterhead, Color (Colour), Prepunched, High Quality, Custom 1 to 8	
	MP Tray	Plain, Transparency, Preprinted, Labels, Bond, Recycled, Rough, Vellum, Letterhead, Color (Colour), Prepunched, Envelope, Cardstock, Thick paper, High Quality, Custom 1 to 8	
Paper Size	Cassette	A4, JIS B5, A5, Folio, Legal, Letter, Oficio II, Statement, Executive, A6, B6, ISO B5, Envelope C5, 16K, Custom (105 × 148 to 216 × 356mm (4-1/8 × 5-13/16 to 8-1/2 × 14 inches))	
	Paper Feeder	A4, JIS B5, A5, Folio, Legal, Letter, Oficio II, Executive, B6, ISO B5, Envelope C5, 16K, Custom (148 × 210 to 216 × 356mm (5-13/16 × 8-5/16 to 8-1/2 × 14 inches))	
	MP Tray	A4, JIS B5, A5, Folio, Legal, Letter, Oficio II, Statement, Executive, A6, B6, ISO B5, Envelope C5, Envelope #10, Envelope #9, Envelope #6-3/4, Envelope Monarch, Envelope DL, Hagaki, Ofuku Hagaki, 16K, Yokei 2, Yokei 4, Custom (70 × 148 to 216 × 356mm (2-13/16 × 5-13/16 to 8-1/2 × 14 inches))	
Magnification ratio	25 to 400%, 1% increments		
Printing Speed	Simplex	A4/Letter: 30 ppm/32 ppm	A4/Letter: 35 ppm/37 ppm
		A5: 17 ppm	
First Print Time (A4, feed from Cassette)	Duplex	A4/Letter: 17 ppm/18 ppm	A4/Letter: 19 ppm/20 ppm
		6 seconds or less	
Warm-up Time (22°C/71.6°F, 60%RH)	Power on	20 seconds or less (120 V AC), 19 seconds or less (220 to 240 V AC)	
	Sleep	15 seconds or less (120 V AC), 14 seconds or less (220 to 240 V AC)	
Paper Capacity	Cassette 1	250 sheets (80 g/m ² , 11 × 8 1/2"/A4 or smaller)	
	Cassette 2	250 sheets (80 g/m ² , 11 × 8 1/2"/A4 or smaller)	
	Cassette 3	—	250 sheets (80 g/m ² , 11 × 8 1/2"/A4 or smaller)
	MP Tray	50 sheets (80 g/m ² , 11 × 8 1/2"/A4 or smaller)	
Output Tray Capacity	Simplex	250 sheets (80 g/m ²)	
	Duplex	200 sheets (80 g/m ²)	
Continuous printing	1 to 999 sheets		
Resolution	Fast 1200, 600 dpi, 300 dpi	Fine 1200, Fast 1200, 600 dpi, 300 dpi	

Item		Description		
		FS-1120D	FS-1320D	
Operating Environment	Temperature	10 to 32.5°C/50 to 90.5°F		
	Humidity	15 to 80 %		
	Altitude	2,500 m/8,202 ft maximum		
	Brightness	1,500 lux maximum		
Controller		PowerPC 405F5/360 MHz		
Supported OS		Microsoft Windows 2000/XP/Vista/7, Windows Server 2003/2008 Mac OS X 10.x		
Interface	Standard	Hi-Speed USB: 1		
	Option	Network Interface Card: 1 (10BASE-T/100BASE-TX)		
PDL		PRESCRIBE		
Memory	Standard	32MB		
	Maximum	544MB		
Dimension (W x D x H)		375 × 393 × 250 mm 14 3/4 × 15 1/2 × 9 7/8"		
Weight (without toner container)		12 kg/26.5 lb		
Power Requirements		120 V AC, 60 Hz, 8.0 A/220 to 240 V AC, 50/60 Hz, 4.2 A		
Power Consumption	Maximum	911 W (U.S.A./Canada), 976 W (European countries)	917 W (U.S.A./Canada), 981 W (European countries)	
	During printing	555.1 W (U.S.A./Canada), 524.1 W (European countries)	573.9 W (U.S.A./Canada), 543.6 W (European countries)	
	During standby	6.6 W (U.S.A./Canada), 7.3 W (European countries) when EcoFuser is On.	6.5 W (U.S.A./Canada), 7.2 W (European countries) when EcoFuser is On.	
		79.8 W (U.S.A./Canada), 82.0 W (European countries) when EcoFuser is Off.	76.5 W (U.S.A./Canada), 80.1 W (European countries) when EcoFuser is Off.	
	Sleep mode	4.3 W (U.S.A./Canada), 4.4 W (European countries)	4.2 W (U.S.A./Canada), 4.3 W (European countries)	
	Power off	0 W		
Options		Expanded memory, Paper Feeder (250-sheet x 1), Network Interface Card (IB-23)	Expanded memory, Paper Feeder (250-sheet x 2), Network Interface Card (IB-23)	

Environmental Standard Requirements

This machine conforms to the following environmental standard requirements.

- Time for switching to Sleep mode (default): 15 minutes
- Duplex Printing: Standard Equipment
- Durable paper for feeding: Paper made of 100% recycled paper

NOTE: Contact your Dealer or Service Representative for recommended paper types.

Index

A

- Adhesive label2-7
- Attention indicator
operation panel1-4

C

- Cancel key1-4
operation panel1-4
- Cassette
 - basis weight2-5
 - loading paper2-11
 - paper sizes2-4
- CF card6-8
option6-2
- Charger cleaner4-7
- Cleaning
 - charger wire4-7
 - printer4-6
 - registration roller4-7
- Clearing paper jams
 - duplexer5-14
 - inside the printer5-15
 - MP tray5-12
 - paper cassette5-13
 - paper feeder5-13
 - rear cover section5-17
- Colored paper2-9
- CompactFlash card6-2, 6-8
- Components
 - at the front of the printer1-2
 - at the rear of the printer1-3
- Connection
 - power cord3-2
 - USB cable3-2
- Custom mode
installation method3-5

D

- Data indicator
operation panel1-4
- Developer unit
 - clearing paper jams5-15
 - maintenance4-6
- DIMM6-2
- Drum unit
 - clearing paper jams5-15
 - maintenance4-6
- Duplexer
 - clearing paper jams5-14

E

- Energy Star programxii
- Envelope2-8

- Environmental standard requirements7-4
- Error indication
 - indicators5-10
- Expansion memory module
option6-2
- Express mode
installation method3-4

F

- Front cover
 - components1-2
- Fuser unit
clearing paper jams5-17

G

- General problems
troubleshooting5-2
- GO key1-4
operation panel1-4

I

- IB-236-2, 6-7
- Indicator combinations
 - error5-10
 - maintenance5-8
 - normal5-5
- Indicators
Ready, Data, Jam, Attention, Toner1-5
- Inside the printer
clearing paper jams5-15
- Installation method
 - custom mode3-5
 - express mode3-4
- Installing CF card6-8
- Installing memory module6-4
- Installing network interface card6-7
- Installing the Printer Driver
 - Mac OS3-5
 - Windows PC3-3

J

- Jam indicator
operation panel1-4

K

- Key
 - Cancel1-6
 - GO1-6

Keys	
GO, Cancel	1-6

L

Label	2-7
Loading paper	
Cassette	2-11
MP tray	2-14
Lock lever	
toner container	4-3

M

Machine parts	1-1
Maintenance	
Toner container replacement, cleaning	4-1
Maintenance indication	
indicators	5-8
Memory module handling	6-3
Moving printer	4-9
MP tray	
basis weight	2-5
clearing paper jams	5-12
components	1-2
loading paper	2-14
minimum and maximum paper sizes	2-3
paper sizes	2-4
paper type	2-10

N

Network interface card	6-7
option	6-2
Normal indication	
indicators	5-5

O

Operation panel	
components	1-2
indicators, keys, overview	1-4
Option	
CF card	6-2
expansion memory module	6-2
network interface card	6-2
paper feeder	6-2
Optional interface slot cover	
components	1-3
Options	6-2

P

Paper	
minimum and maximum sizes	2-3
Paper cassette	
clearing paper jams	5-13
components	1-2
minimum and maximum page sizes	2-3
paper type	2-10

Paper feeder	6-6
clearing paper jams	5-13
option	6-2
Paper gauge	2-13
Paper guides	2-14
Paper indicator	
operation panel	1-4
Paper length guide	2-12
Paper stopper	
components	1-2
Paper weight	2-5
PF-100	6-2, 6-6
Possible paper jam locations	5-11
Postcard	2-8
Power cord	
connection	3-2
Power cord connector	
components	1-3
Power switch	
components	1-3
Preparing paper	2-11
Preprinted paper	2-9
Print quality problems	
troubleshooting	5-3
Prolonged non-use	4-9

R

Ready indicator	
operation panel	1-4
Rear cover	
components	1-3
Rear cover section	
clearing paper jams	5-17
Recycled paper	2-9
Registration roller	
cleaning	4-7
Removing memory module	6-5
Replacement	
toner container	4-2, 4-3
Replacing toner container	4-3
Right cover	
components	1-2

S

Special paper	2-7
Specifications	7-2
Environmental specifications	7-4
Starter container	
toner container	4-2
Subtray	
components	1-2

T

Tips	5-2
Toner container	
how to replace	4-3
replacement	4-2

Toner indicator	
operation panel	1-4
replacing toner container	4-2
Toner kit	
toner container, plastic waste bag, installation guide	4-2
Top cover	
components	1-2
Top tray	
components	1-2
Transparency	2-7
Troubleshooting	5-1
general problems	5-2
print quality problems	5-3
Turning on the power	3-2

U

Understanding indicators	5-5
USB cable	
connection	3-2
USB interface connector	
components	1-3

V

Verifying expanded memory	6-5
---------------------------------	-----



KYOCERA MITA AMERICA, INC.

Headquarters:

225 Sand Road,
Fairfield, New Jersey 07004-0008
TEL : (973) 808-8444
FAX : (973) 882-6000

New York Branch:

1410 Broadway 23rd floor
New York, NY 10018
TEL : (917) 286-5400
FAX : (917) 286-5402

Northeastern Region:

225 Sand Road,
Fairfield, New Jersey 07004-0008
TEL : (973) 808-8444
FAX : (973) 882-4401

Midwestern Region:

201 Hansen Court Suite 119
Wood Dale, Illinois 60191
TEL : (630) 238-9982
FAX : (630) 238-9487

Western Region:

14101 Alton Parkway,
Irvine, California 92618-7006
TEL : (949) 457-9000
FAX : (949) 457-9119

Southeastern Region:

1500 Oakbrook Drive,
Norcross, Georgia 30093
TEL : (770) 729-9786
FAX : (770) 729-9873

Southwestern Region:

2825 West Story Road,
Irving, Texas 75038-5299
TEL : (972) 550-8987
FAX : (972) 252-9786

National Operation Center & National Training Center:

2825 West Story Road,
Irving, Texas 75038-5299
TEL : (972) 659-0055
FAX : (972) 570-5816

Latin America Division:

8240 N.W. 52nd. Terrace Dawson Building,
Suite 108 Miami, Florida 33166
TEL : (305) 421-6640
FAX : (305) 421-6666

KYOCERA MITA CANADA, LTD.

6120 Kestrel Road, Mississauga,
Ontario L5T 1S8, Canada
TEL : (905) 670-4425
FAX : (905) 670-8116

KYOCERA MITA MEXICO, S.A. DE C.V.

Av. 16 de Septiembre #407
Col. Santa Inés,
Azcapotzalco México,
D.F. 02130, México
TEL : (55) 5383-2741
FAX : (55) 5383-7804

PASSIONATE PEOPLE. FROM ALL OVER THE WORLD.



KYOCERA MITA EUROPE B.V.



EUROPEAN HEADQUARTERS
Bloemlaan 4
2132 NP Hoofddorp
The Netherlands
Phone: +31 20 654 0000
Fax: +31 20 653 1256
www.kyoceramita-europe.com



KYOCERA MITA Europe B.V.,
Amsterdam (NL)
Zweigniederlassung Zürich
Hohlstrasse 614
CH-8048 Zürich
Phone: +41 1 908 49 49
Fax: +41 1 908 49 50
www.kyoceramita.ch

KYOCERA MITA SALES COMPANIES IN EMEA



KYOCERA MITA INTERNATIONAL SALES
(Europe, Middle East & North Africa)
Bloemlaan 4
2132 NP Hoofddorp
The Netherlands
Phone: +31 20 654 0000
Fax: +31 20 653 1256
www.kyoceramita-europe.com



AUSTRIA
KYOCERA MITA AUSTRIA GmbH
Eduard Kittenberger Gasse 95
A-1230 Wien
Phone: +43 1 86 338 0
Fax: +43 1 86 338 400
www.kyoceramita.at



BELGIUM
S.A. KYOCERA MITA Belgium N.V.
Sint-Martinusweg 199-201
BE-1930 Zaventem
Phone: +32 2 720 9270
Fax: +32 2 720 8748
www.kyoceramita.be



DENMARK
KYOCERA MITA Denmark A/S
Ejby Industrivej 1
DK-2600 Glostrup
Phone: +45 70 22 3880
Fax: +45 45 76 3850
www.kyoceramita.dk



FINLAND
KYOCERA MITA Finland OY
Kirvesmiehenkatu 4
FI-00880 Helsinki
Phone: +358 9 4780 5200
Fax: +358 9 4780 5390
www.kyoceramita.fi



FRANCE
KYOCERA MITA France S.A.
Parc les Algorithmes Saint Aubin
FR-91194 Gif-Sur-Yvette
Phone: +33 1 6985 2600
Fax: +33 1 6985 3409
www.kyoceramita.fr



GERMANY
KYOCERA MITA Deutschland GmbH
Otto-Hahn-Str. 12
D-40670 Meerbusch / Germany
Phone: +49 2159 918 0
Fax: +49 2159 918 100
www.kyoceramita.de



ITALY
KYOCERA MITA Italia S.P.A.
Via Verdi, 89/91
I-20063 Cernusco sul Naviglio (MI)
Phone: +39 02 921 791
Fax: +39 02 921 796 00
www.kyoceramita.it



THE NETHERLANDS
KYOCERA MITA Nederland B.V.
Beechavenue 25
1119 RA Schiphol-Rijk
Phone: +31 20 587 7200
Fax: +31 20 587 7260
www.kyoceramita.nl



NORWAY
KYOCERA MITA Norge
Olaf Helsetsvai 6
NO-0694 Oslo
Phone: +47 22 627 300
Fax: +47 22 627 200
www.kyoceramitanorge.no



PORTUGAL
KYOCERA MITA Portugal LDA.
Rua do Centro Cultural 41
PT-1700-106 Lisboa
Phone: +351 21 843 6780
Fax: +351 21 849 3312
www.kyoceramita.pt



SOUTH AFRICA
KYOCERA MITA South Africa (Pty) Ltd.
527 Kyalami Boulevard, Kyalami
Business Park · ZA-1685 Midrand
Phone: +27 11 540 2600
Fax: +27 11 466 3050
www.kyoceramita.co.za



SPAIN
KYOCERA MITA España S.A.
Avda. Manacor No. 2
ES-28290 Las Matas (Madrid)
Phone: +34 91 631 83 92
Fax: +34 91 631 82 19
www.kyoceramita.es



SWEDEN
KYOCERA MITA Svenska AB
Esbogatan 16B
SE-164 75 Kista
Phone: +46 8 546 550 00
Fax: +46 8 546 550 10
www.kyoceramita.se



UNITED KINGDOM
KYOCERA MITA UK Ltd.
8 Beacontree Plaza, Gillette Way,
Reading, Berkshire RG2 OBS
Phone: +44 1189 311 500
Fax: +44 1189 311 108
www.kyoceramita.co.uk

KYOCERA MITA WORLDWIDE



JAPAN
KYOCERA MITA Corporation
(Head Office)
2-28, 1-Chome, Tamatsukuri, Chuo-ku,
Osaka 540-8585, Japan
Phone: +81 6 6764 3555
Fax: +81 6 6764 3980
www.kyoceramita.com



USA
KYOCERA MITA America, INC.
(Head office)
225 Sand Road, P.O. Box 40008
Fairfield, New Jersey 07004-0008, USA
Phone: +1 973 808 8444
Fax: +1 973 882 6000
www.kyoceramita.com/us

KYOCERA CORPORATION



JAPAN
KYOCERA CORPORATION
(Corporate Headquarters)
6 Takeda Tobadono-cho, Fushimi-ku
Kyoto 612-8501, Japan
Phone: +81 75 604 3500
Fax: +81 75 604 3501
www.kyocera.co.jp

 **KYOCERA**

